

Raymarine®

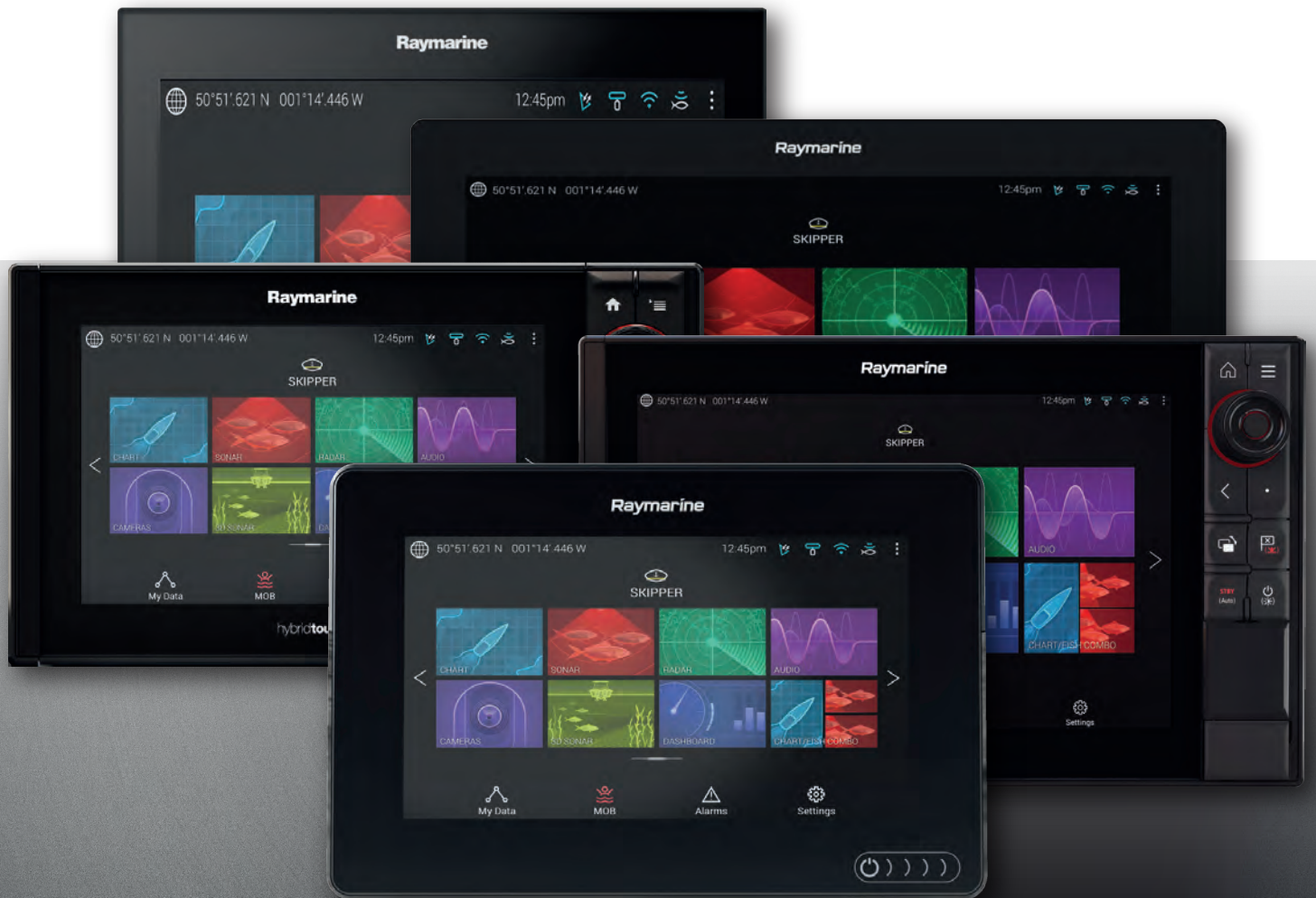

LIGHTHOUSE 3

VERSION 3.11

Advanced operation instructions

English (en-US)
Date: 11-2019
Document number: 81370-14
© 2019 Raymarine UK Limited

Trademark and patents notice

Raymarine, Tacktick, Clear Pulse, Truzoom, SeaTalk, SeaTalk^{hs}, SeaTalkng, and **Micronet**, are registered or claimed trademarks of Raymarine Belgium.

FLIR, LightHouse, DownVision, SideVision, RealVision, HyperVision, Dragonfly, Element, Quantum, Axiom, Instalert, Infrared Everywhere, The World's Sixth Sense and **ClearCruise** are registered or claimed trademarks of FLIR Systems, Inc.

All other trademarks, trade names, or company names referenced herein are used for identification only and are the property of their respective owners.

This product is protected by patents, design patents, patents pending, or design patents pending.

Fair Use Statement

You may print no more than three copies of this manual for your own use. You may not make any further copies or distribute or use the manual in any other way including without limitation exploiting the manual commercially or giving or selling copies to third parties.

Software updates



Check the Raymarine website for the latest software releases for your product.
www.raymarine.com/software

Product documentation



The latest versions of all English and translated documents are available to download in PDF format from the website: www.raymarine.com/manuals.
Please check the website to ensure you have the latest documentation.

Publication copyright

Copyright ©2019 Raymarine UK Ltd. All rights reserved.

Contents

Chapter 1 Important information	17
Disclaimers	17
Open source license agreements	17
Regulatory approvals	17
Warranty registration	17
Technical accuracy	18
Chapter 2 Document and product information	19
2.1 Product documentation	20
Video tutorials	20
Applicable software version	20
Compatible MFDs	20
New software features	21
User manuals Print Shop	21
Chapter 3 General information	23
3.1 MFD and LightHouse third-party apps	24
3.2 Sidebar	25
Customizing Sidebar data	25
Switching sidebars	26
Enable rudder bar	26
3.3 Data overlays	27
Data overlay and Sidebar data items	27
3.4 Menus	28
Controls and settings	29
3.5 MFD app settings menu	29
3.6 Editing the split ratio of a Splitscreen app page	30
Chapter 4 Set up	31
4.1 MFD physical buttons	32
4.2 Axiom and Axiom XL	33
Powering on the display	33
Powering off the display	34
Switching on and off at the breaker	34
4.3 Axiom Pro, eS Series and gS Series	34
Powering on the display	34
Powering off the display	35
4.4 Switching on and off at the breaker	35
4.5 Getting started	35
First power up	35
First power up Data master selection	36
Startup wizard	36

First power up Limitation on Use acknowledgement	36
Multiple data sources (MDS)	36
Data sources menu	37
Identifying engines	37
Configuring Transducer settings	38
RealVision™ 3D AHRS calibration.....	38
Transducer calibration (iTC-5).....	39
Assigning a function to the User Programmable Button (UPB).....	41
Performing a settings or factory reset.....	42
Importing user data.....	42
4.6 Shortcuts	42
Taking a screenshot	43
Activating touchlock	43
Radar standby.....	43
Autopilot shortcuts.....	43
Adjusting brightness	43
Disabling all sounders.....	43
Bluetooth volume control	43
4.7 Memory card compatibility	44
Removing MicroSD card from its adaptor	45
Inserting a MicroSD card — Axiom variants	45
Inserting a MicroSD card — Axiom Pro variants.....	46
Inserting external storage devices - RCR.....	46
4.8 Software updates	47
Updating software using a memory card.....	47
Updating software via the internet	48
4.9 Device pairing.....	48
Pairing a RMK remote keypad	48
Pairing with a Quantum Radar scanner	48
Pairing a Bluetooth speaker	49
Chapter 5 Homescreen	51
5.1 Accepting the Limitations on Use	52
5.2 Homescreen overview	52
5.3 MFD Apps.....	53
5.4 Creating / Customizing an App page.....	55
5.5 User profiles.....	56
Demo profiles	56
5.6 Status area	58
Status area icons	58
5.7 Satellite navigation / positioning	60
GNSS (GPS) Status.....	60

GNSS (GPS) Settings.....	60
5.8 My data.....	61
Fuel/trip manager	61
Files	64
View PDFs	64
Import/export.....	64
5.9 Secure messaging	65
Message inbox.....	66
New broadcast.....	66
New direct message	66
Reply to messages.....	67
Onscreen keyboard	67
Message symbols	67
5.10 Alarms	68
Alarm manager	69
Alarm settings.....	71
External alarm speaker / buzzer	73
Acknowledging alarms	73
Digital switching alarms	73
5.11 Man Overboard (MOB).....	74
MOB mode.....	75
5.12 Settings	75
Selecting display language.....	77
Boat details.....	77
Units of measure.....	80
Data master	81
Shared Brightness	81
Customizing the splashscreen.....	82
NMEA 0183 settings.....	83
Responder setup	84
5.13 Connecting to a wireless display.....	85
Disconnecting a wireless display.....	86
Unpairing a wireless display	86

Chapter 6 Autopilot control 87

6.1 Autopilot control.....	88
Engaging the autopilot — Locked heading.....	88
Engaging the autopilot — Navigation	88
Engaging and disengaging the autopilot - physical buttons.....	89
Disengaging the autopilot	89
6.2 Pilot sidebar	89
6.3 Pilot pop-up.....	91

6.4 Autopilot Control — Advanced settings	91
Chapter 7 Waypoints, Routes and Tracks	95
7.1 Waypoints	96
Placing a waypoint.....	96
Waypoint management.....	96
7.2 Routes	98
Creating a Route	98
Autorouting	99
Importing a route	100
Route management	100
7.3 Tracks	101
Creating a track	102
Converting a track to a route	102
Track management.....	102
Chapter 8 Chart app	105
8.1 Chart app overview.....	106
Chart app controls	107
Chart ranging and panning	107
Chart app context menu	108
Selecting a chart card	108
Chart modes	109
Vessel details.....	110
Object selection and information.....	110
Layers	111
View and motion.....	112
Camera tracking	112
8.2 Navigation	113
Navigating to a waypoint or point of interest.....	113
Restarting cross track error (XTE)	113
Following a Route	113
8.3 SAR (Search and Rescue) Patterns	114
Sector search pattern	114
Expanding square search pattern.....	117
Creeping line / Parallel line search pattern.....	121
8.4 Laylines.....	122
Sailing data page	123
Laylines — system requirements	124
Enabling Laylines	124
Laylines settings	124
Displaying and interpreting laylines.....	125
Displaying wind shift data	126

8.5 Race Start Line (SmartStart) and Race Timer.....	127
Creating the Race Start Line.....	128
Starting the Race Timer.....	130
Race laylines.....	130
Race sidebar.....	131
Dashboard.....	132
8.6 Target tracking.....	132
Target vectors.....	133
Dangerous targets alarm.....	134
Radar settings.....	135
AIS settings.....	136
AIS target symbols.....	136
Blue Force overview.....	139
Blue Force SITREP.....	139
8.7 Collision avoidance.....	140
Enabling collision avoidance.....	142
Collision scenarios.....	143
Example scenario 1 — Own vessel moving faster than target vessel.....	143
Example scenario 2 — Target vessel moving faster than your vessel.....	146
Example scenario 3 — Both vessels travelling at the same speed.....	148
8.8 Target intercept.....	149
8.9 Tides mode.....	150
Using animation controls.....	150
Setting a specific date for animations.....	151
Tide station information.....	151
Current station information.....	152
Displaying tide or current graphs.....	154
8.10 RealBathy™.....	154
Setting up and creating RealBathy contours.....	155
8.11 Find nearest.....	156
Search using find nearest.....	157
8.12 SonarChart™ Live.....	158
Enabling SonarChart Live.....	159
8.13 UAV Chart integration.....	159
Showing or hiding the UAV icon.....	160
Performing a UAV Goto.....	160
8.14 ClearCruise™ Augmented Reality.....	160
Field of View.....	161
8.15 Chart settings menu.....	161
Chapter 9 Weather mode.....	169
9.1 Weather mode.....	170

9.2 Activating your SiriusXM receiver	171
SR200 diagnostics mode	171
Weather receiver status	171
9.3 Animated weather	172
9.4 Weather mode context menu	173
9.5 Weather Radar layer	173
9.6 Cities and Surface observation stations layers	175
9.7 Cloud top and Lightning layers.....	176
9.8 Storm cast and Storm tracks layers	177
9.9 Sea surface temperature and Surface pressure layers.....	178
Surface pressure patterns	179
9.10 Wind and Watchbox layers.....	180
9.11 Wave direction, height and period layers.....	181
Chapter 10 Fishfinder app.....	183
10.1 Fishfinder app overview	184
Fishfinder app controls	184
RealVision 3D controls.....	185
10.2 Opening the Fishfinder app	186
10.3 Sonar channels.....	188
Selecting a Sonar channel.....	189
10.4 Placing a Waypoint (Sonar, DownVision and SideVision).....	189
Placing a waypoint RealVision 3D	189
10.5 Sonar scroll back	190
10.6 Sonar sensitivity controls.....	191
10.7 Fishfinder settings menu.....	192
Chapter 11 Radar app.....	197
11.1 Radar app overview.....	198
Radar app controls.....	198
Radar app context menu	199
Camera tracking	200
11.2 Radar feature comparison	200
Compatible Radar scanners.....	203
11.3 Opening the Radar app.....	203
Putting the radar into standby	204
Powering down your radar scanner.....	204
11.4 Set up	205
Selecting a Radar scanner.....	205
Dual range	205
Timed Radar transmission	206
Setting open array antenna size	206
Bearing alignment.....	206

11.5 Radar modes	206
11.6 Range and bearing	208
VRM (Variable Range Marker) / EBL (Electronic Bearing Line).....	208
11.7 AIS targets.....	210
AIS target list.....	210
AIS target symbols.....	211
AIS settings.....	213
11.8 Radar targets.....	214
Radar target acquisition data source requirements.....	214
Radar target symbols.....	215
Acquiring a target manually.....	216
Automatic target acquisition.....	216
Radar target list.....	217
Target settings.....	218
Onscreen target settings.....	220
Clearing / resetting trails.....	220
Target context menu	221
11.9 Dangerous targets alarm	221
11.10 Guard zone alarms	222
11.11 Doppler Radar overview.....	223
Doppler mode.....	223
Doppler data source requirements.....	224
11.12 Blank sectors.....	224
11.13 Radar sensitivity controls.....	225
11.14 Radar settings	226
Chapter 12 Dashboard app	231
12.1 Dashboard app overview.....	232
Dashboard app controls	232
Switching data page	233
Selecting Data pages to display	233
12.2 Default data pages	233
12.3 Customizing existing Data pages	234
Available data items.....	234
12.4 Dashboard settings menu.....	238
12.5 Navigation and Sailing dials	241
Sailing dials for laylines.....	242
Sailing data items.....	242
Race Start data items.....	243
Chapter 13 Yamaha app	245
13.1 Yamaha app overview.....	246
Requirements	246

Yamaha app controls.....	246
Switching data page	247
13.2 Customizing Data pages.....	247
Available data items.....	248
13.3 Engine page.....	251
Engines	252
Transmission	253
Status and warning indicators.....	254
Tanks	255
Engine trim.....	255
Troll mode.....	256
13.4 Settings.....	256
Fault codes	256
Maintenance	256
Advanced.....	257
Chapter 14 Video app	259
14.1 Video app overview.....	260
Video app pages	260
Renaming video feeds.....	261
Video app controls	261
Pan, Tilt, Zoom (PTZ) camera controls	262
14.2 Opening the Video app.....	262
Selecting a video feed.....	263
Dual streaming.....	263
14.3 Video app settings.....	264
14.4 Maritime (M-Series) camera compatibility	267
Chapter 15 ClearCruise (Object Detection and Augmented Reality)	273
15.1 ClearCruise™ features.....	274
15.2 Camera setup.....	275
Fixed camera calibration.....	275
Pan and Tilt camera calibration	277
15.3 AR200 setup for Augmented Reality	279
15.4 ClearCruise™ object detection overview.....	279
ClearCruise settings (Object Detection)	280
15.5 Augmented Reality (AR) overview	281
15.6 Augmented Reality flags.....	282
Selected flags	283
Goto flag	285
15.7 ClearCruise settings (Augmented Reality)	286
Range limit.....	287
15.8 Roll correction	288

15.9 AR200 Calibration (Linearization).....	290
Magnetic deviation	290
AR200 calibration settings	290
Continual monitoring and adaptation	291
Compass lock	292
Chapter 16 Audio app	293
16.1 Audio app overview.....	294
Compatible entertainment systems	294
Audio app controls	296
16.2 Opening the Audio app.....	298
16.3 Getting started.....	300
Selecting an audio zone	300
Selecting an audio source	300
Muting and unmuting.....	300
Browsing for tracks	301
Browsing for stations / channels.....	301
Saving presets	301
Powering off entertainment systems	301
16.4 Audio app menu options.....	302
Audio app settings menu.....	303
Adjusting balance and fade controls	304
Adjusting multi-zone controls	304
SR200 diagnostics mode	305
Chapter 17 PDF Viewer app	307
17.1 PDF Viewer app overview	308
17.2 Opening PDF files	308
17.3 PDF Viewer controls	308
17.4 Searching a PDF.....	310
Chapter 18 UAV (Unmanned Aerial Vehicle) app	311
18.1 UAV disclaimer.....	312
18.2 UAV app overview.....	312
Compatible UAVs	313
UAV sport mode	313
UAV app settings menu.....	313
18.3 UAV pre-requisites	314
Removing the RC cable	314
UAV controller connection	315
18.4 UAV precautions.....	316
No-fly zones.....	317
18.5 Getting started	317
18.6 UAV app page.....	317

18.7 Opening the UAV app	318
18.8 Launching the UAV	320
18.9 Controlling the UAV in flight.....	320
18.10 Retrieving your UAV	321
18.11 Disconnect UAV remote controller from MFD	321
18.12 Fish on / Circle me mode.....	321
18.13 UAV Chart integration.....	322
Showing or hiding the UAV icon.....	323
Performing a UAV Goto	323
18.14 UAV Emergency procedures	323
Chapter 19 LightHouse third-party apps	325
19.1 LightHouse app launcher	326
LightHouse third-party apps	326
19.2 Lighthouse third-party apps - Preloaded	327
19.3 Lighthouse third-party apps - Downloadable	328
19.4 Installing Lighthouse third-party apps	328
19.5 Internet connection	329
Connecting to the internet.....	329
Wi-Fi settings	329
19.6 Bluetooth speaker set up	330
Enabling and disabling Bluetooth	330
Bluetooth Settings	330
Pairing a Bluetooth speaker	331
Bluetooth volume control	331
Chapter 20 Mobile app support	333
20.1 Raymarine mobile apps	334
20.2 Connect to Wi-Fi - Android	334
20.3 Connect to Wi-Fi - iOS.....	335
20.4 Controlling your MFD using RayControl	335
20.5 Controlling your MFD using RayRemote	336
20.6 Viewing your MFD screen using RayView.....	337
20.7 Navionics plotter sync	337
20.8 Fishidy sync	337
Enable sync.....	338
Disable sync.....	339
Chapter 21 Troubleshooting	341
21.1 Troubleshooting	342
21.2 Diagnostic product information.....	342
Saving product information.....	342
21.3 Power up troubleshooting	343
Performing a power on reset — Axiom™	343

Performing a power on reset - Axiom Pro.....	344
Performing a Power on Reset - eS and gS Series MFDs	344
21.4 Radar troubleshooting.....	345
21.5 GNSS (GPS) troubleshooting.....	346
21.6 Sonar troubleshooting.....	346
21.7 Camera troubleshooting	349
21.8 Augmented Reality (AR) Troubleshooting	351
21.9 Wi-Fi troubleshooting	352
21.10 Wireless display troubleshooting	354
21.11 Data troubleshooting	355
21.12 Touchscreen troubleshooting.....	355
Chapter 22 Technical support.....	357
22.1 Raymarine product support and servicing.....	358
Viewing product information (LightHouse™ 3).....	359
22.2 Learning resources.....	360
Appendix A NMEA 0183 sentence support	361
Appendix B NMEA 2000 PGN support	362
Appendix C Document change history	364
Appendix D Hardware compatibility.....	369
Appendix E LightHouse 3 on eS and gS Series.....	370

Chapter 1: Important information



Warning: Ensure safe navigation

This product is intended only as an aid to navigation and must never be used in preference to sound navigational judgment. Only official government charts and notices to mariners contain all the current information needed for safe navigation, and the captain is responsible for their prudent use. It is the user's responsibility to use official government charts, notices to mariners, caution and proper navigational skill when operating this or any other Raymarine product.



Warning: Radar transmission safety

The radar scanner transmits electromagnetic energy. Ensure all personnel are clear of the scanner when the radar is transmitting.



Warning: Sonar operation

- NEVER operate the sonar with the transducer out of the water.
- NEVER touch the transducer face when the sonar is powered on.
- SWITCH OFF the sonar if divers are likely to be within 7.6 m (25 ft) of the transducer.

Disclaimers

Raymarine does not warrant that this product is error-free or that it is compatible with products manufactured by any person or entity other than Raymarine.

This product uses digital chart data, and electronic information from Global Navigation Satellite Systems (GNSS) which may contain errors. Raymarine does not warrant the accuracy of such information and you are advised that errors in such information may cause the product to malfunction. Raymarine is not responsible for damages or injuries caused by your use or inability to use the product, by the interaction of the product with products manufactured by others, or by errors in chart data or information utilized by the product and supplied by third parties.

This product supports electronic charts provided by third party suppliers which may be embedded or stored on memory card. Use of such charts is subject to the supplier's End-User Licence Agreement.

Open source license agreements

This product is subject to certain open source license agreements. Copies of the license agreements can be found on the Raymarine website: www.raymarine.com/manuals/.

Regulatory approvals

Regulatory approvals are available to view on your MFD from the settings menu, **Homescreen** > **Settings** > **Regulatory approvals**

Warranty registration

To register your Raymarine product ownership, please visit www.raymarine.com and register online.

It is important that you register your product to receive full warranty benefits. Your unit package includes a bar code label indicating the serial number of the unit. You will need this serial number when registering your product online. You should retain the label for future reference.

Technical accuracy

To the best of our knowledge, the information in this document was correct at the time it was produced. However, Raymarine cannot accept liability for any inaccuracies or omissions it may contain. In addition, our policy of continuous product improvement may change specifications without notice. As a result, Raymarine cannot accept liability for any differences between the product and this document. Please check the Raymarine website (www.raymarine.com) to ensure you have the most up-to-date version(s) of the documentation for your product.

Chapter 2: Document and product information

Chapter contents

- [2.1 Product documentation on page 20](#)

2.1 Product documentation

The following documentation is applicable to your product:

All documents are available to download in PDF format from the Raymarine website www.raymarine.com.

Description	Part number
LightHouse 3 Basic operation instructions	81369
LightHouse 3 Advanced operation instructions	81370
LightHouse™ 2 to LightHouse™ 3 upgrade procedure	81378
Axiom MFD Installation instructions	87298
Axiom Pro MFD Installation instructions	87319
Axiom XL MFD Installation instructions	87344
RMK-10 Remote Keypad Installation and operation instructions	81367
RMK-9 Remote Keypad Installation and operation instructions	81351

Video tutorials

A range of tutorial videos is available on the Raymarine website to assist you in learning how to use your product.

<http://www.raymarine.com/multifunction-displays/lighthouse3/tips-and-tricks>

Applicable software version

Product software is updated regularly to add new features and improve existing functionality.

This handbook is applicable to MFD operating system software: LightHouse™ 3 Release version 3.11.

Check the website for the latest software and user manuals:

- www.raymarine.com/software
- www.raymarine.com/manuals

Compatible MFDs

The LightHouse™ 3 operating system is compatible with the MFDs listed below.

Software version	Compatible MFDs
LH3.11 LH3.10.71 LH3.10 LH3.9 LH3.8 LH3.7 LH3.6 LH3.5	<ul style="list-style-type: none">• Axiom XL• Axiom Pro• Axiom• eS Series• gS Series
LH3.4 LH3.3	<ul style="list-style-type: none">• Axiom Pro• Axiom• eS Series• gS Series
LH3.2	<ul style="list-style-type: none">• Axiom Pro• Axiom
LH3.1	<ul style="list-style-type: none">• Axiom
LH3.0	<ul style="list-style-type: none">• Axiom

New software features

The following new features have been added to Release 3.11 of the LightHouse™ 3 operating system.

- Arabic Keyboard.
- Secure Responder Messaging available for responder vessels.
- iTC-5 Calibration.
- Victron Energy third-party app.
- Fishidy Sync.
- Dual streaming for dual payload cameras.
- Expanding Square search and rescue pattern.

User manuals Print Shop

Raymarine provides a Print Shop service, enabling you to purchase a high-quality, professionally-printed manual for your Raymarine product.

Printed manuals are ideal for keeping onboard your vessel, as a useful source of reference whenever you need assistance with your Raymarine product.

Visit <http://www.raymarine.co.uk/view/?id=5175> to order a printed manual, delivered directly to your door.

For further information about the Print Shop, please visit the Print Shop FAQ pages: <http://www.raymarine.co.uk/view/?id=5751>.

Note:

- Accepted methods of payment for printed manuals are credit cards and PayPal.
- Printed manuals can be shipped worldwide.
- Further manuals will be added to the Print Shop over the coming months for both new and legacy products.
- Raymarine user manuals are also available to download free-of-charge from the Raymarine website, in the popular PDF format. These PDF files can be viewed on a PC / laptop, tablet, smartphone, or on the latest generation of Raymarine multifunction displays.

Chapter 3: General information

Chapter contents

- [3.1 MFD and LightHouse third-party apps on page 24](#)
- [3.2 Sidebar on page 25](#)
- [3.3 Data overlays on page 27](#)
- [3.4 Menus on page 28](#)
- [3.5 MFD app settings menu on page 29](#)
- [3.6 Editing the split ratio of a Splitscreen app page on page 30](#)

3.1 MFD and LightHouse third-party apps

Depending on your MFD variant 2 types of app may be available on your display.

MFD apps



MFD apps are opened from app page icons available on the Homescreen, these apps include Chart, Radar, Fishfinder etc. MFD apps are available on all MFDs running the LightHouse™ 3 operating system. Multiple apps can be displayed simultaneously by creating splitscreen app pages.

LightHouse™ third-party apps

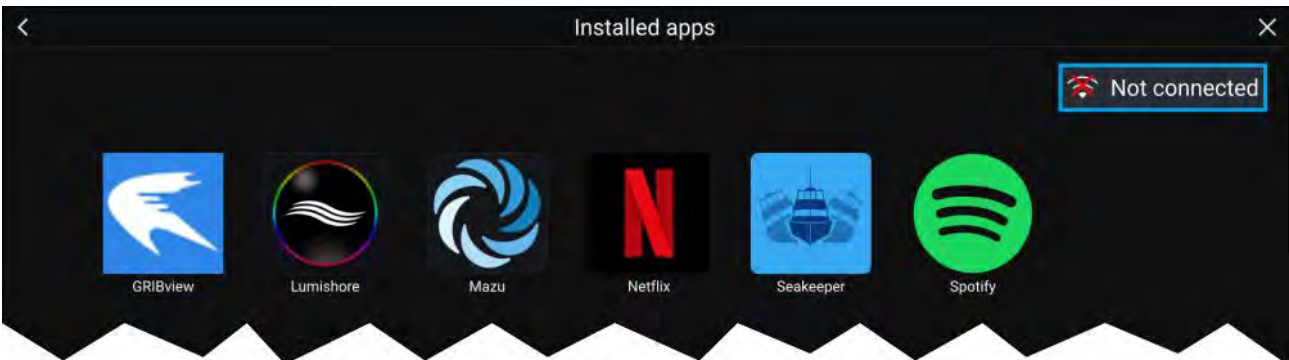

LightHouse™ third-party apps are developed entirely by 3rd parties and are approved by Raymarine. These apps are available from the LightHouse app launcher found on the Homescreen. LightHouse™ third-party apps are only available on the Axiom™ range of MFDs.

3.2 Sidebar

The Sidebar is available in all apps and provides quick access to system data. By default the Sidebar is set up to display navigation data.

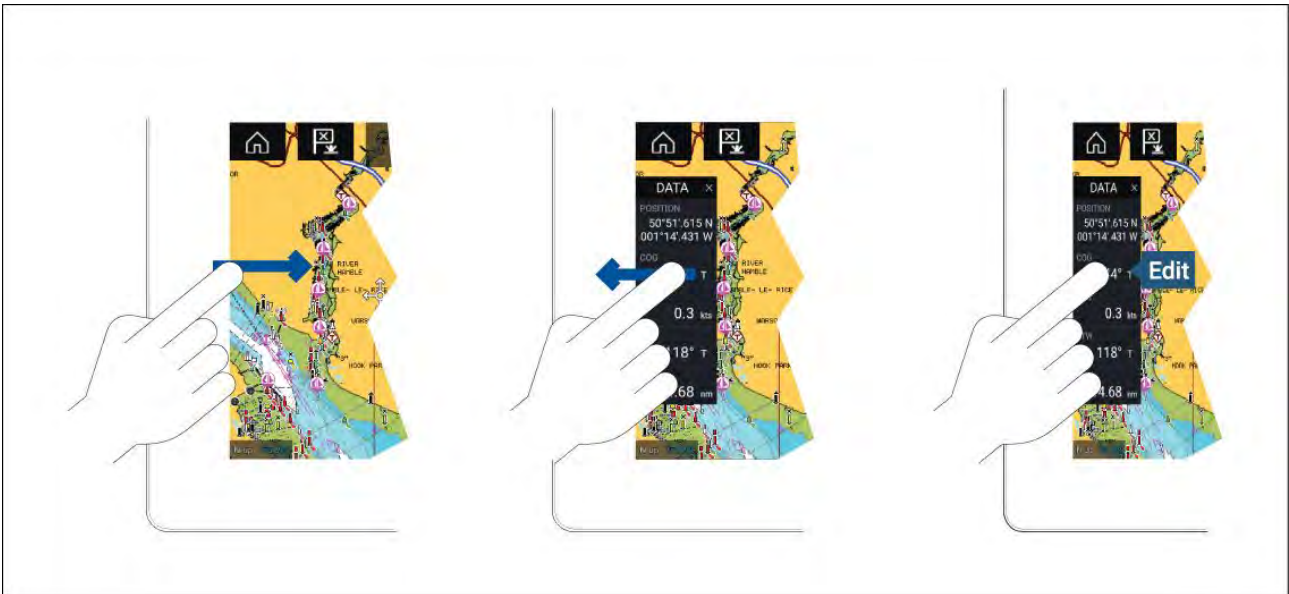

The Sidebar is displayed automatically in the Chart app when a Goto or follow is initiated. It can also be displayed at anytime by sliding your finger from left to right from the left edge of the screen. Swiping right to left will hide the Sidebar.

To customize the displayed data, press and hold on the Data item you want to change and select **Edit** from the pop-over options.

Customizing Sidebar data

The data displayed in the Sidebar can be customized by following the steps below.

1. Open any app and from the left edge of the screen swipe from left to right.
2. Press and hold on the Data type you want to customize.
3. Select Edit from the pop-over menu.
4. Select the data type you want to be displayed.

Switching sidebars

Different Sidebars are available.

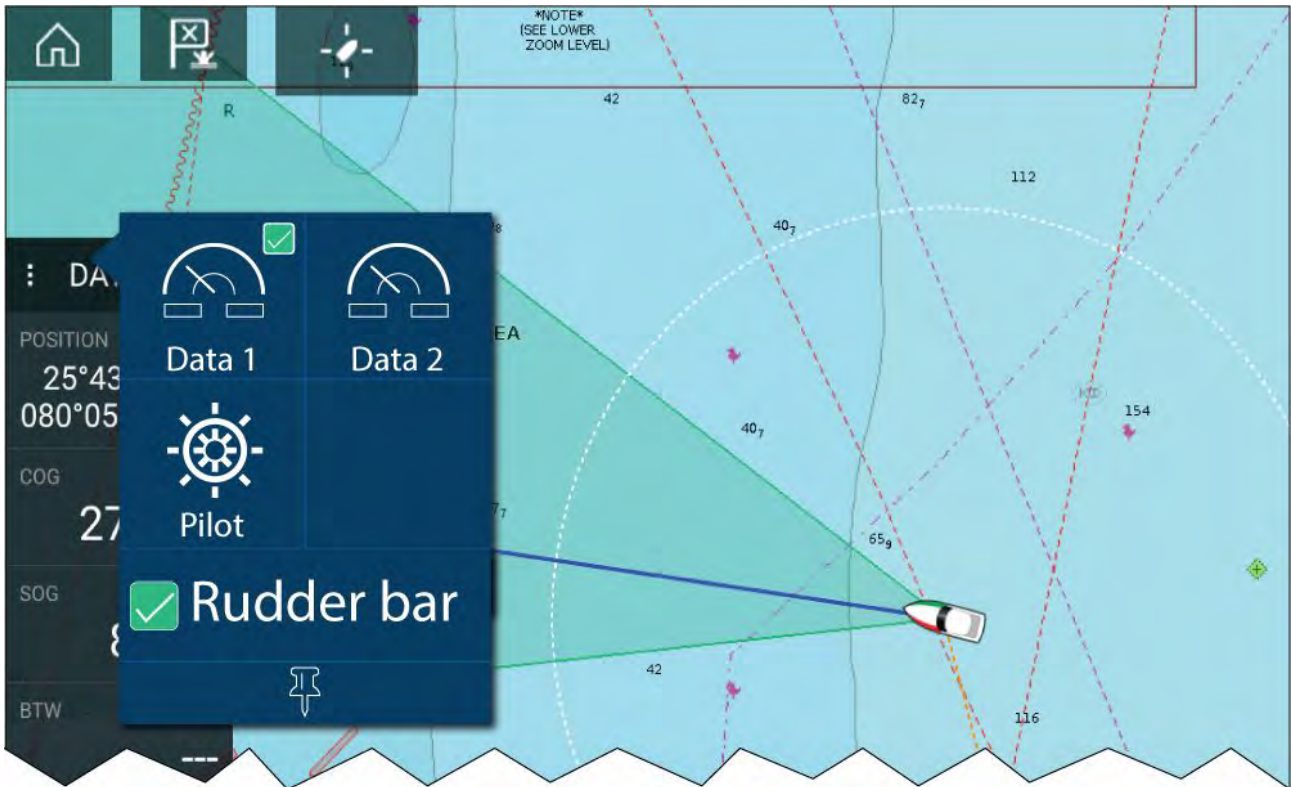

To switch Sidebars:

1. Select the **Sidebar selection** icon.
2. Select the Sidebar you want to use.
3. You can also pin the Sidebar so that it is always displayed onscreen in the app you are in.

Enable rudder bar

The Rudder bar is located at the bottom of the Sidebar, it displays the position of your vessel's rudder.

Note: A rudder position sensor must be on the same network as your MFD for the Rudder bar to function.

To enable the Rudder bar:

1. Select the Sidebar selection icon.
2. Select Rudder bar to enable / disable its display at the bottom of the Sidebar.

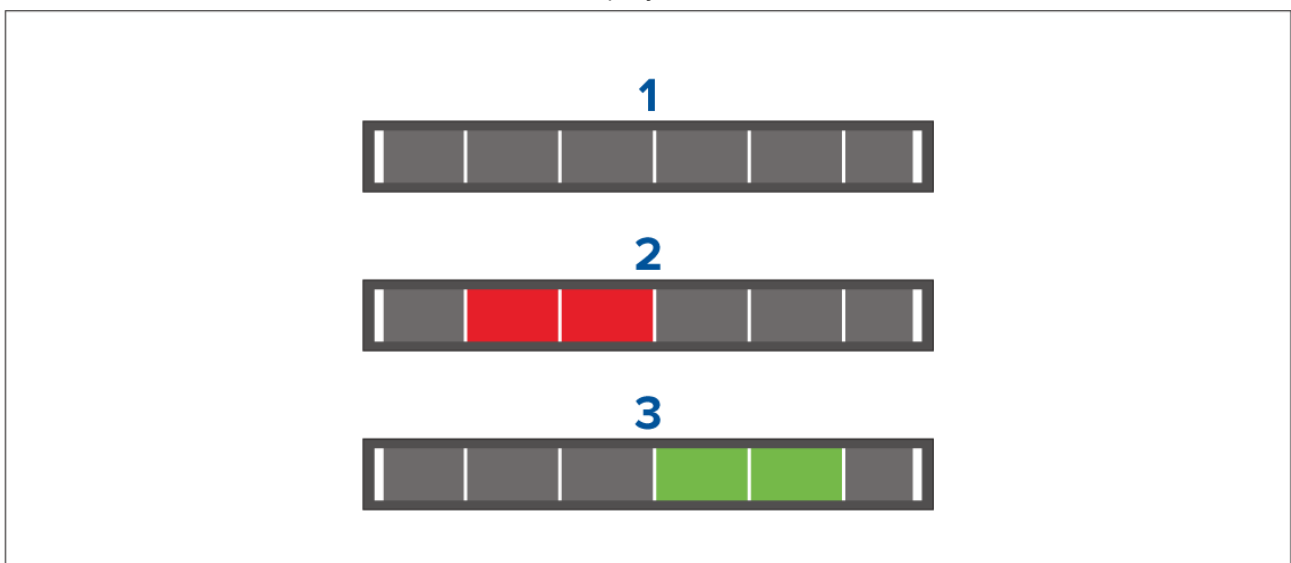

1. No rudder data found.
2. Rudder deflection to port.

3. Rudder deflection to starboard.

3.3 Data overlays

System data can be overlaid onto the Chart, Radar, Sonar or Camera apps. Some apps have Data overlays enabled by default.

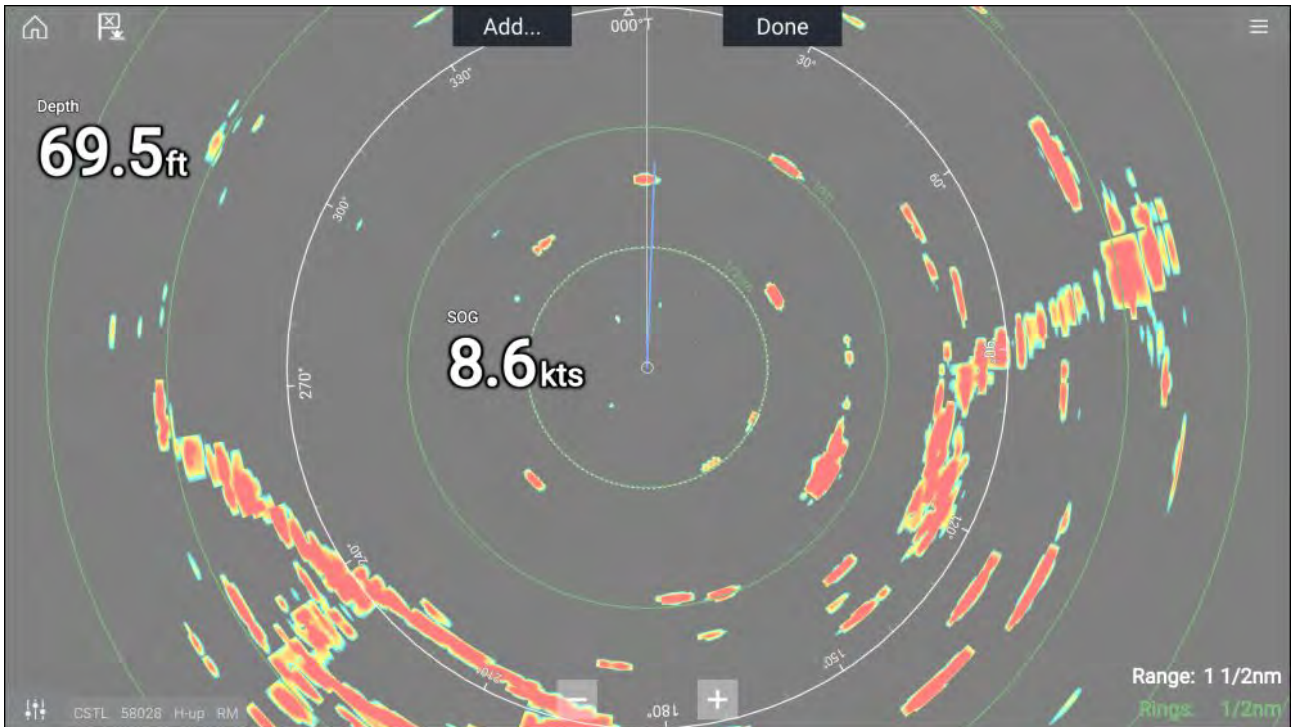

Data overlays can be placed anywhere on the app page and can be placed over any app in a Splitscreen app page.

Data overlays can be customized from: **Menu > Settings > Page Settings > Edit data overlays.**

In edit mode, drag the data overlay to the desired location. Touch and hold a Data overlay to display the pop-over menu, where you can **Edit, Move, Resize** or **Delete** the Data overlay.

Select **Add** to add another overlay or **Done** to exit edit mode.





Data overlay and Sidebar data items

The following data items are available to be displayed in Data overlays and Sidebars.

GPS Position (one line) (GNSS position)	Supply voltage
GPS Position (two lines) (GNSS position)	Waypoint TTG (Time To Go)
Local time	Waypoint ETA (Estimated Time of Arrival)
Depth	State of charge
Water temperature	Time till zero charge
Cursor position	Loran Position (one line)
Loran Cursor position	Loran Position (two lines)
COG (Course Over Ground)	TWS (True Wind Speed)
SOG (Speed Over ground)	TWA (True Wind Angle)
Heading	TWD (True Wind Direction)
STW (Speed Through Water)	AWS (Actual Wind Speed)
Bearing to waypoint	AWA (Actual Wind Angle)
Distance to waypoint	

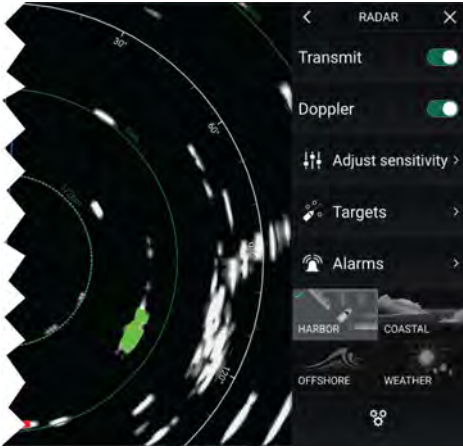

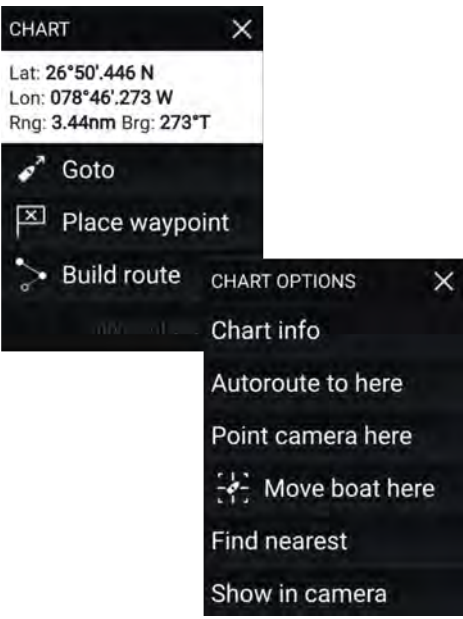

3.4 Menus

The different types of menu available in LightHouse™ 3 are shown below.

	<p>The Main menu is displayed on the right side of the screen when the Menu icon is selected.</p>
	<p>Main menu Each MFD app includes a main menu. Main menus provide access to the MFD app's features and settings, via menu options and menu pages. Selecting Back (<), Close (X) or selecting an area of the screen away from the menu, will close the menu. Selecting a menu item with a right arrow (>) will open a menu page or other menu options for that item.</p>
	<p>Menu pages Menu pages are accessed from main menu options and icons found on the Homescreen. Menu pages are fullscreen pages containing menu options and settings. Menu pages are usually set out in tabs with each tab containing options relevant to the tab's title. Selecting tab titles will display the contents for that tab. Selecting Back (<) or Close will close the menu.</p>
	<p>Context menus Context menus are available in MFD apps. Context menus are accessed by selecting an object or location within the MFD app. Context menus provide context-sensitive information and options. Selecting more options will display further contextual menu options. Selecting Close (X) or selecting an area of the screen away from the menu, will close the menu.</p>
	<p>Pop-over menus Pop-over menus are available on the Homescreen, in MFD apps and from Menu pages. Pop-over options provide access to further menu options and settings. Selecting an area of the screen away from the menu will close the menu.</p>

Controls and settings

Common menu controls and options are detailed below.

	<p>Toggle switch Toggle switches are used to enable (switch on) or disable (switch off) various features and settings. When enabled (switched on) the white circle will be moved right and the switch's background will be filled Green.</p>
	<p>Page down Selecting will page down the current menu or page. When displayed you can also swipe the page to scroll up or down.</p>
	<p>Setting field Setting fields show the selected value for that control. Selecting a setting field will display the available options relevant to the options available. Depending on available options this could be in the following formats:</p> <ul style="list-style-type: none"> • Pop-over options (selection list) • Numeric value control • Onscreen keyboard • File browser • Selection list (full page)
	<p>Setting button Setting buttons are available on Menu pages and Notification / Alarm messages to access further settings or confirm setting changes or changed MFD state.</p>

3.5 MFD app settings menu

Each MFD app includes a settings menu that provides access to the app's settings and features.

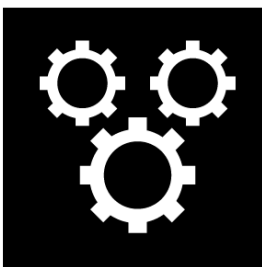

The settings menu in each MFD app is signified by the Settings icon, found in the main app menu.

3.6 Editing the split ratio of a Splitscreen app page

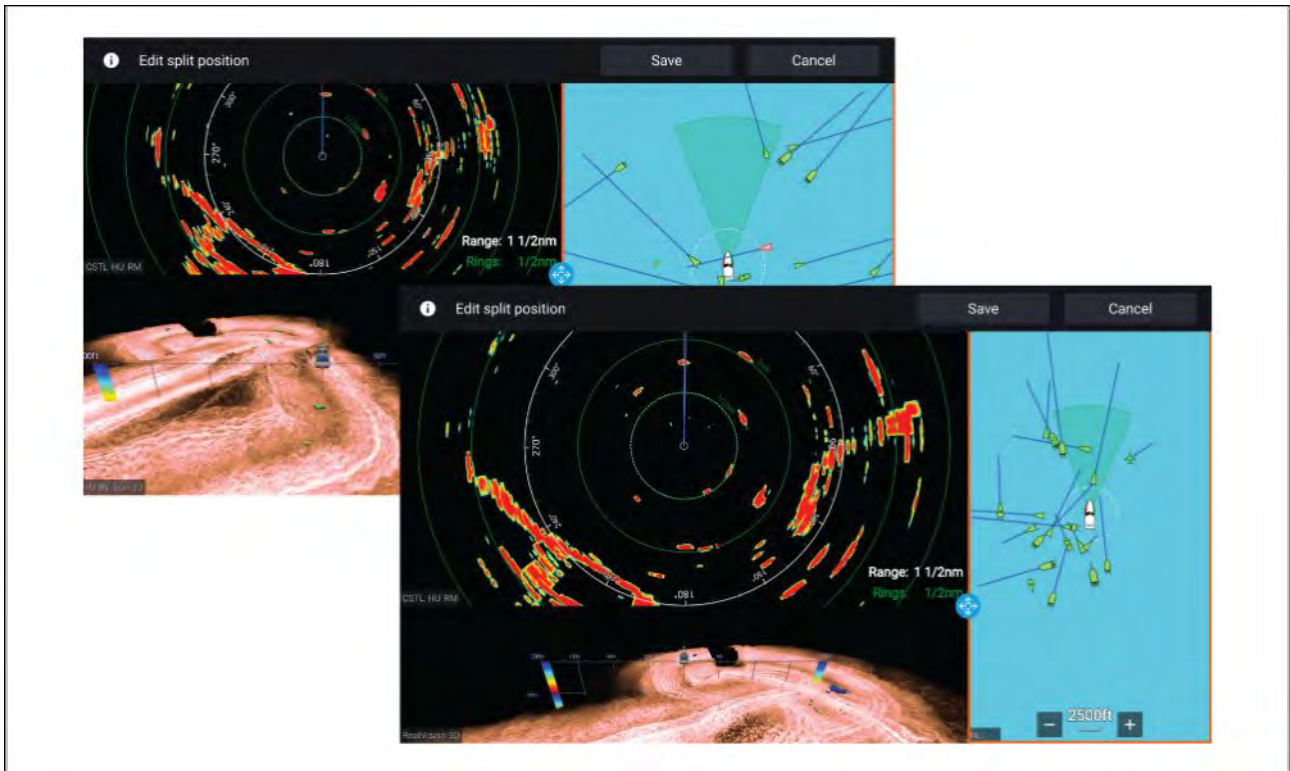

With a Splitscreen app page displayed:

1. Select **Edit split ratio** from the **Page settings** tab: **Menu > Settings > Page settings > Edit split ratio**.
2. Drag the Resize icon to create the desired split ratio.
3. Select **Save**.

Chapter 4: Set up

Chapter contents













- 4.1 MFD physical buttons on page 32
- 4.2 Axiom and Axiom XL on page 33
- 4.3 Axiom Pro, eS Series and gS Series on page 34
- 4.4 Switching on and off at the breaker on page 35
- 4.5 Getting started on page 35
- 4.6 Shortcuts on page 42
- 4.7 Memory card compatibility on page 44
- 4.8 Software updates on page 47
- 4.9 Device pairing on page 48

4.1 MFD physical buttons

The table below shows the physical buttons that are available on LightHouse™ 3 compatible MFDs and remote keypads, along with their function.

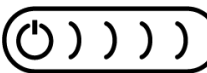
Note:	
<ul style="list-style-type: none"> Where 2 button symbols are shown, the symbols on the left represent Axiom™ Pro variant MFDs or RMK-10 keypad, and the symbols on the right represent an eS Series MFD or RMK-9 keypad. Axiom MFDs and gS Series MFDs only have a single power button. 	

Physical MFD buttons

Control	Button	Function
 	Home	Press to display the Homescreen.
 	Menu	Press to open or close menus.
	⁽¹⁾ User Programmable Button (UPB)	You can select which function this button controls. Refer to Assigning a function to the User Programmable Button (UPB) for more information.
 	Waypoint / MOB	Press momentarily to place a waypoint at your vessel's location. A long press activates the Man overboard (MOB) alarm.
 	Power	Press to power on the MFD. When the MFD is powered on, pressing this button displays the Shortcuts page.
	⁽²⁾ Power swipe	Swipe to power on the MFD. When the MFD is powered on, swipe again to display the Shortcuts page.
STBY (Auto) Standby (Auto)	Pilot	Press momentarily to display or hide the Pilot sidebar. A long press engages the autopilot in locked heading mode, or disengages an active autopilot.
	Switch	Press momentarily to switch the active pane in a splitscreen page. A long press expands the selected pane.
 	Back	Press to return to the previous menu or dialog.
	Range In	Press to Range or Zoom In.

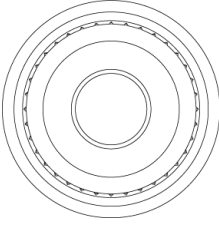
Control	Button	Function
	Range Out	Press to Range or Zoom Out.
	Uni-controller	The Uni-controller consists of a center OK button, Directional controls and a Rotary knob.

MFD Uni-controller

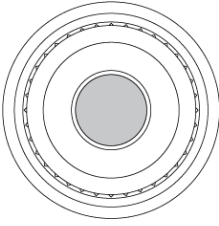
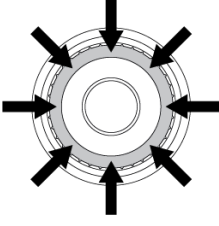
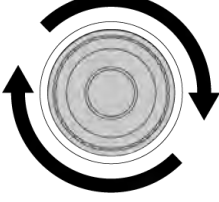
Control	Control	Function
	Ok	Push the button to confirm a selection.
	Directional	Use the 8-way directional controls to reposition the cursor onscreen.
	Rotary	Turn clockwise to Range or Zoom In and counterclockwise to Range or Zoom out.

<p>Note:</p> <ul style="list-style-type: none"> • ⁽¹⁾ The UPB is only available on Axiom™ Pro MFDs. • ⁽²⁾ The Power swipe is only available on Axiom™ MFDs.
--

4.2 Axiom and Axiom XL

Powering on the display

When power is available to the MFD but the MFD is switched off, the Power symbol will be illuminated. To power on the display:

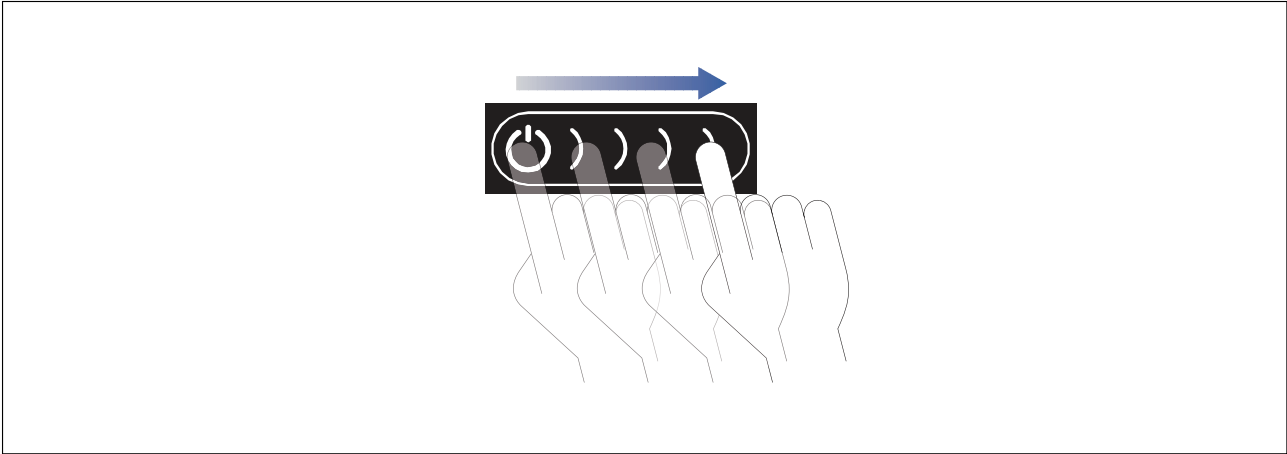

1. Swipe your finger from left to right across the **Power** button swipe area.
The MFD will power up.

Powering off the display

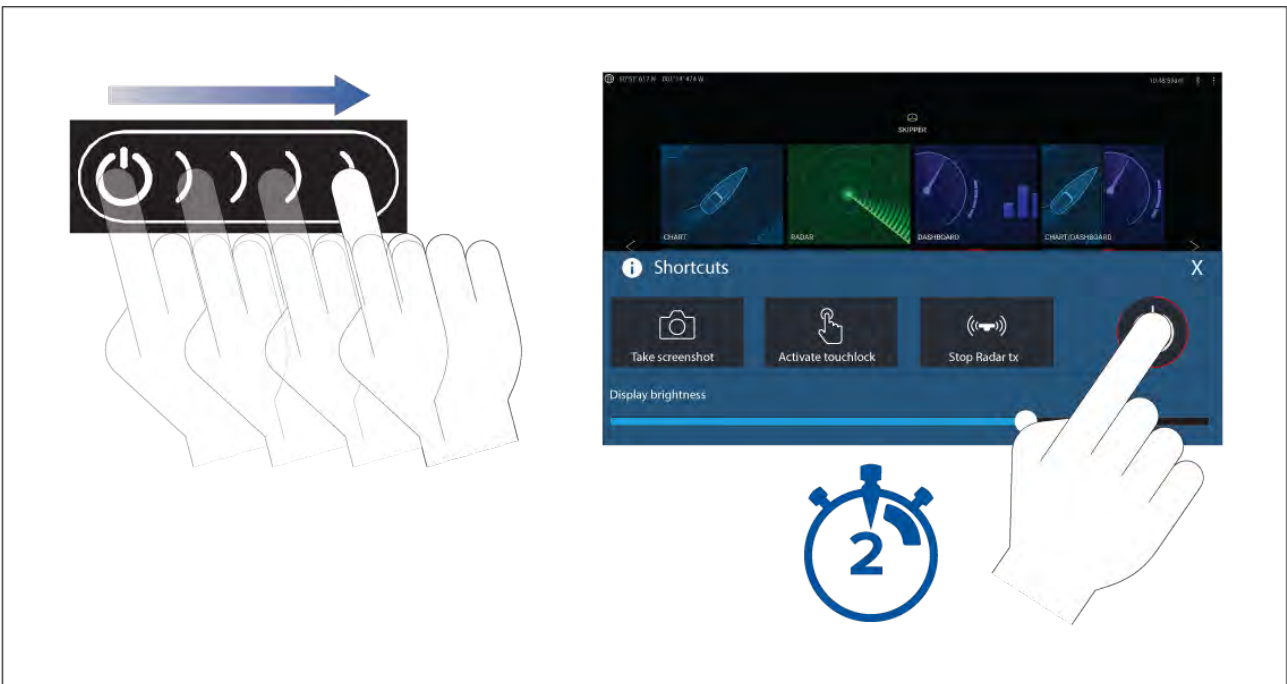

1. Swipe your finger from left to right across the **Power** button swipe area.
The Shortcuts menu is displayed.
2. Press and hold the **Power symbol** until the screen switches off.

Note:

When powered off, the unit may still draw a small amount of power from the battery. If this is a concern, unplug the power supply or switch off at the breaker.

Switching on and off at the breaker

If you wish to ensure that the MFD is not consuming any power then it must be switched off at the breaker or have the power cable unplugged.

When the breaker is switched back on, or the cable is reconnected, the MFD will resume in the same power state that it was in when it was switched off.

4.3 Axiom Pro, eS Series and gS Series

Powering on the display

1. Press the power button to power on the display.

Powering off the display

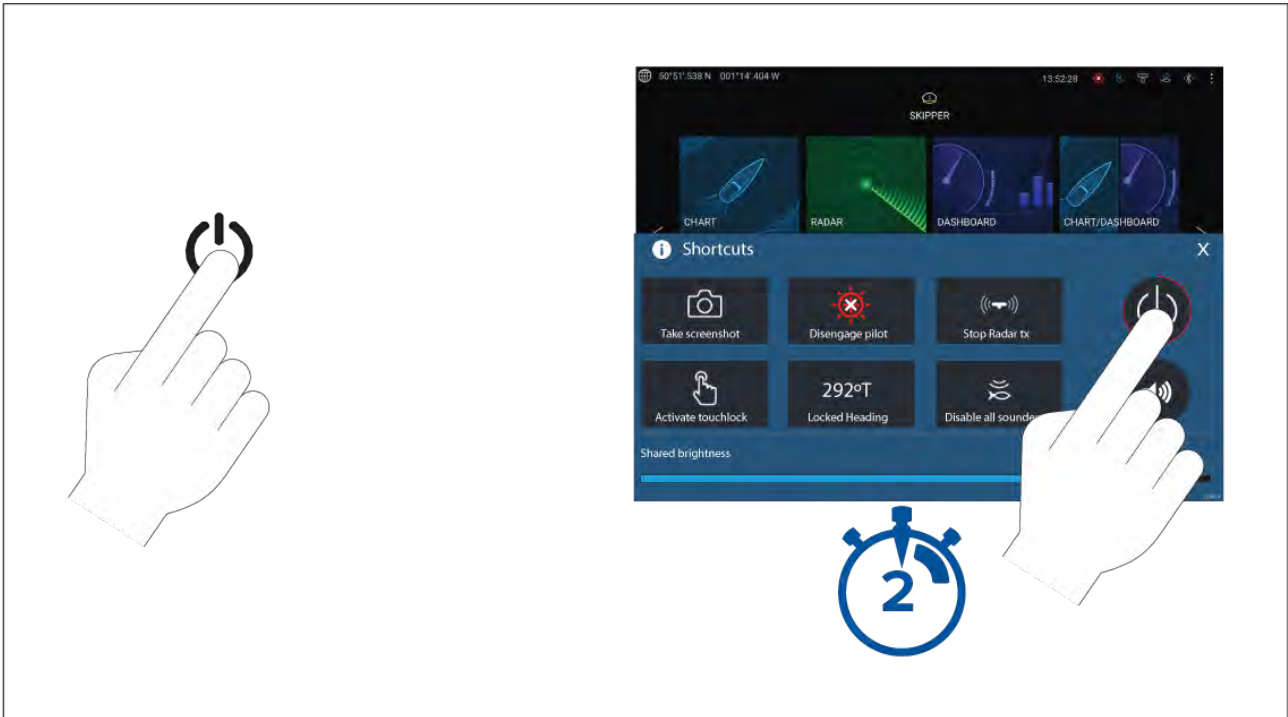

1. Press the **Power** button.
2. From the Shortcuts page press and hold the power icon for approximately 2 seconds.

Alternatively you can press and hold the **Power** button for approximately 6 seconds to power off your display.

Note:

When powered off, the unit may still draw a small amount of power from the battery. If this is a concern, unplug the power supply or switch off at the breaker.

4.4 Switching on and off at the breaker

If you wish to ensure that the MFD is not consuming any power then it must be switched off at the breaker or have the power cable unplugged.

When the breaker is switched back on, or the cable is reconnected, the MFD will resume in the same power state that it was in when it was switched off.

4.5 Getting started

First power up

When you power up your new Multifunction Display (MFD) for the first time a number of actions are required.

The list below shows the actions that should be performed on your new MFD:

1. **Power** on the display.
2. Select your **Data master** (only required on networks with more than 1 MFD).
3. Complete the **Startup wizard** (the wizard will not be shown if you are connecting to an existing system that has already been set up).
4. Read and agree to the **Limitations on Use** disclaimer.
5. Select/check your preferred **Data sources**, if required.
6. Perform **Engine identification**, if required.
7. Select/check **Transducer settings**, if required

First power up Data master selection

Networks containing more than 1 MFD must have a designated Data master. The Data master is the primary MFD in the network and should be the MFD that is connected to the SeaTalkng® / NMEA 2000 CAN bus network and any other devices and sources of data in your system. The Data master bridges the data over the SeaTalkhs™ network to any compatible networked 'repeater' MFDs.

By default your MFD will be set as a Data master. If you are connecting to a network that already includes MFDs then on first power up you will be requested to confirm your Data master.

The "Multiple Data masters found" warning will be displayed whenever a new MFD is added to your network.

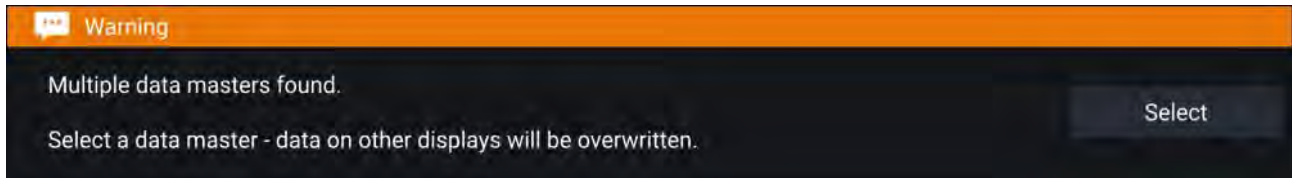

You can change your Data master at anytime by selecting **Assign as Data master** against a MFD listed in the Network tab of the Settings menu: **Homescreen > Settings > Network**.

Startup wizard

If the MFD is being installed as a stand alone installation or as part of a new system, then the first time the MFD is powered up the Startup wizard will be displayed. The Startup wizard will help you configure important settings on your MFD.

Follow the onscreen instructions and configure the relevant settings.

The Startup wizard will also be displayed after a **Factory reset** is performed.

First power up Limitation on Use acknowledgement

After you have completed the Startup wizard the Limitation on Use (LoU) disclaimer is displayed.

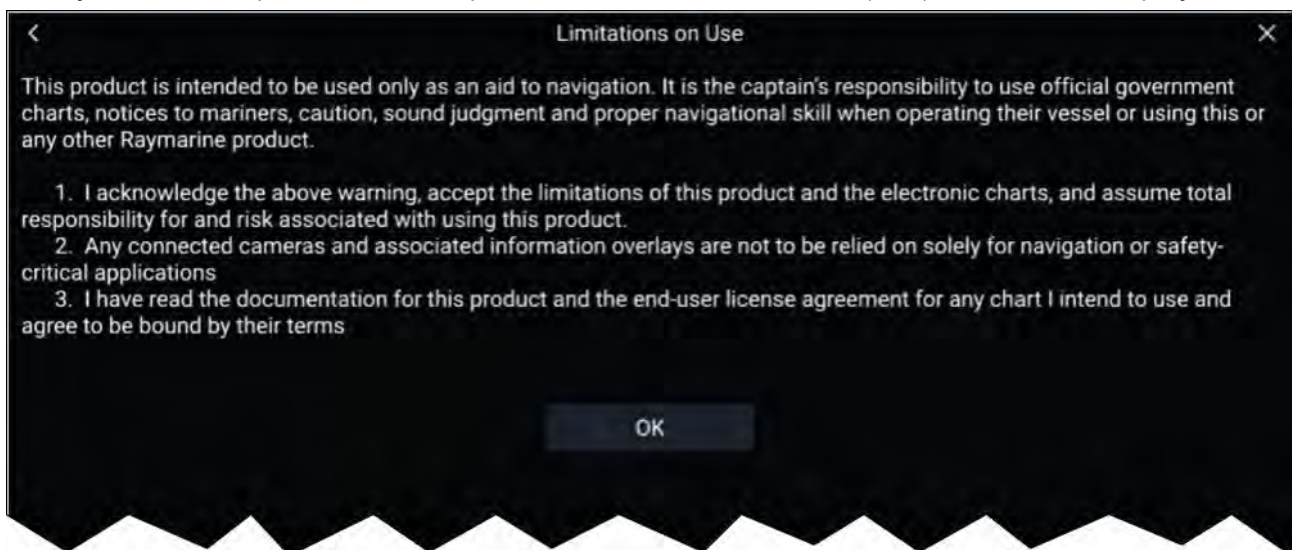

You must read and agree to the terms in order to use your MFD.

Selecting **OK** means you have accepted the terms of use.

Multiple data sources (MDS)

MDS is a Raymarine scheme for managing multiple sources of identical data types on any single network (e.g.: in a MFD network you may have more than one source of GPS / GNSS position data).

The following data types can have a preferred source assigned to them:

- GPS Position
- GPS Datum
- Time & Date
- Heading
- Depth

- Speed
- Wind

For MDS to be available on your system, all products in the system that use the data sources must be MDS-compliant. The system will report any products that are NOT MDS-compliant. It may be possible to upgrade the software for these non-compliant products, to make them compliant. Visit the Raymarine website (www.raymarine.com) to obtain the latest software for your products.

If MDS-compliant software is not available for the product and you do NOT want to use the system's preferred data source, you must remove any non-compliant products from the system. You should then be able to select your preferred data source.

Note:
Once you have completed setting up your preferred data sources, you may be able to add non-compliant products back into the system.

Data sources menu

When a system includes multiple sources of a data type, such as depth data, the system will choose the most appropriate source for the data. If you prefer, you can manually select your own data source.

The **Data sources** menu can be accessed on your Data master MFD, from the **Settings** menu: **Homescreen > Settings > Network > Data sources**.

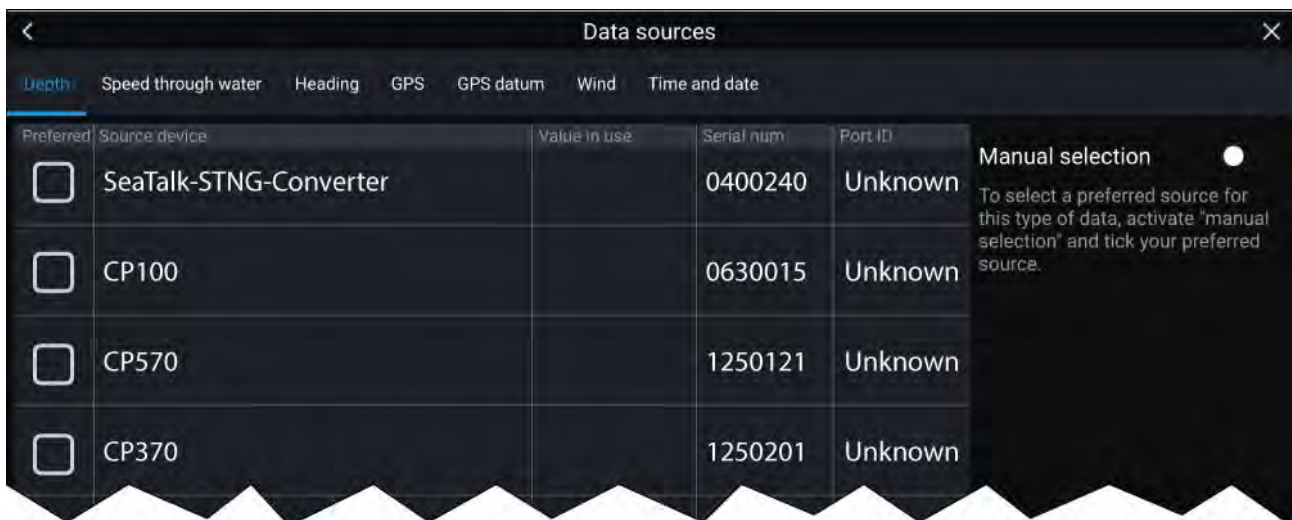

Each tab enables you to view and select your preferred data source. The currently active data source will display its current value in use. Data source selection can be manual or set to automatic:

- **Auto** — your MFD will automatically select a device.
- **Manual** — you can manually select your preferred device.

Networked MFDs will automatically be updated to use the Data sources selected on your Data master MFD.

Identifying engines

Engine data can be shown on your display, if your engines are transmitting the relevant supported data on the same network as your display. If your system has mislabelled your engines then you can correct this using the Engine identification wizard.

The Engine identification wizard can be accessed from the Boat details menu: **Homescreen > Settings > Boat details > Identify engines**.

1. Ensure the correct number of engines is selected in the **Num of Engines** box.
2. Select **Identify engines**.
3. Follow the onscreen prompts to complete the engine identification wizard.

Configuring Transducer settings

For systems set up with Sonar, you should configure your transducer settings.

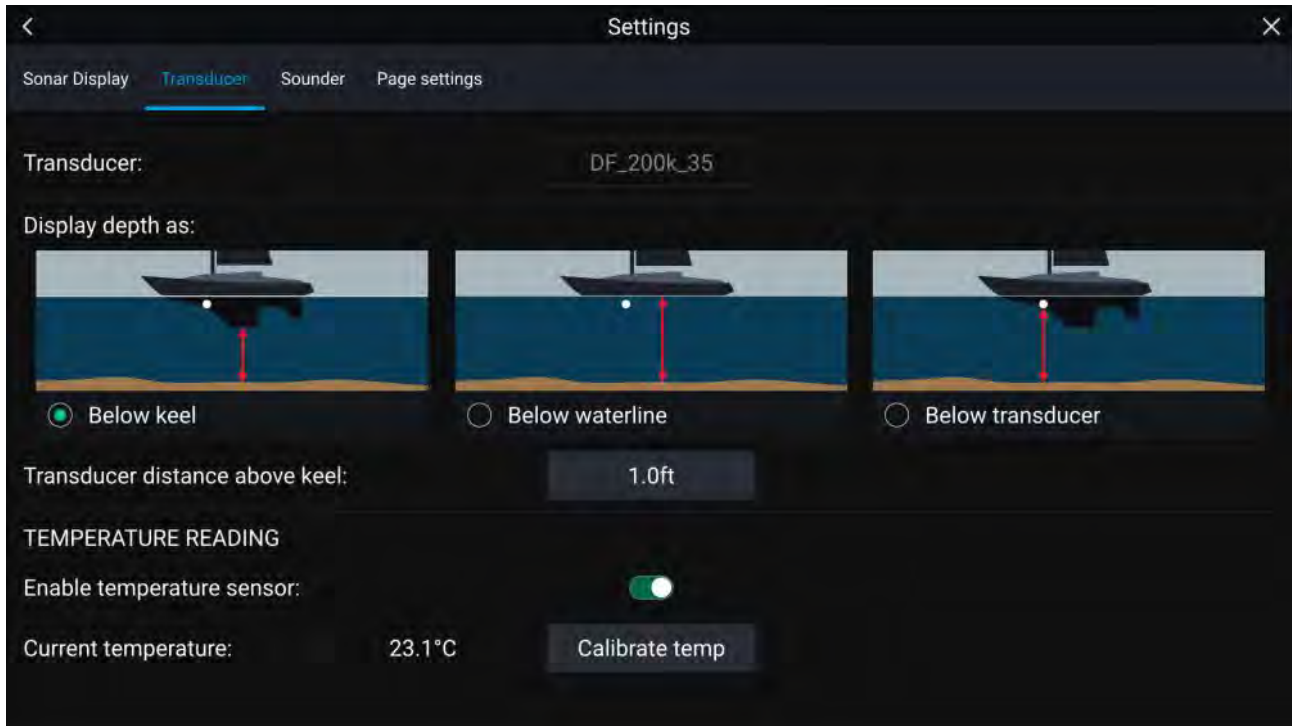

1. Select **Transducer** from the Fishfinder app's **Settings** menu: **Menu > Settings > Transducer**
2. Select how you want your depth to appear:
 - i. Below transducer (default) — No offset required
 - ii. Below keel — Enter the distance between the transducer face and the bottom of the Keel.
 - iii. Below waterline — Enter the distance between the bottom of your Keel and the waterline.
3. If your transducer includes a temperature sensor then you can also configure temperature settings as follows:
 - i. Enable or disable temperature readings as required.
 - ii. If enabled, check the temperature reading against the actual water temperature.
 - iii. If the current reading requires adjustment, select **Calibrate temp** and enter the difference between your 2 readings.

RealVision™ 3D AHRS calibration

RealVision™ 3D transducers include a built-in AHRS (Attitude and Heading Reference Sensor), which measures the motion of your vessel to assist in the rendering of sonar images. After installation all RealVision™ 3D transducers require calibration.

An uncalibrated transducer can produce an offset to the front edge of the render of the bottom in the sonar image, as illustrated below.

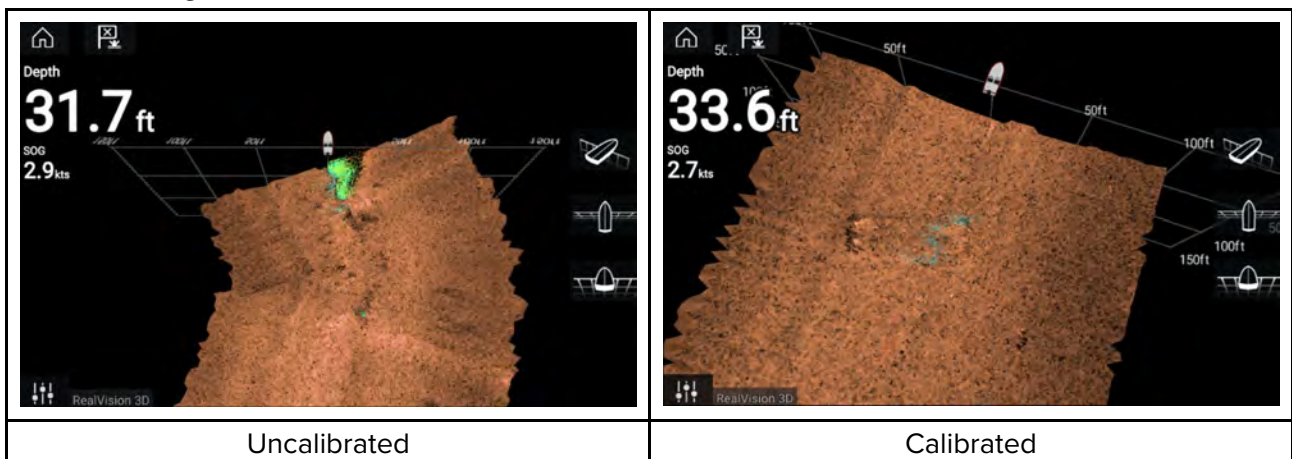

Calibration is an automatic process and starts after your vessel has turned approximately 100° at a speed of between 3 –15 knots. Calibration requires no user input, however at least a 270° turn is required before the calibration process can determine the local deviation and apply a relevant offset.

The time it takes to complete the calibration process will vary according to the characteristics of the vessel, the installation environment of the transducer, and the levels of magnetic interference at the time of conducting the process. Sources of significant magnetic interference may increase the time required to complete the calibration process. Certain areas with substantial magnetic deviation may require extra circles or “figure of 8” manoeuvres to be performed. Examples of such sources of magnetic interference include:

- Vessel engines
- Vessel alternators
- Marine pontoons
- Metal-hulled vessels
- Underwater cables

Note:

In some circumstances, it is beneficial to disable Realvision AHRS if local sources of magnetic interference are distorting the sonar image. Realvision AHRS can be disabled from **Settings**.

Menu > Settings > Sounder > AHRS stabilization

Note:

The Calibration process will require repeating after a **Sonar reset** or **MFD Factory reset**.

Transducer calibration (iTC-5)

You can calibrate transducers connected to your Lighthouse MFD via an iTC-5 Instrument Transducer Converter.

Note:

Transducer calibration requirements:

- An iTC-5 Instrument Transducer Converter.
- An MFD designated as the Data master.
- LightHouse software version 3.11 or later.

Note:

You can only calibrate transducers that are directly connected to the iTC-5 instrument you select for calibration. In systems with more than 1 iTC-5, it is important to remember which transducer(s) are connected to each iTC-5 instrument.

Network

To calibrate transducers, find the relevant iTC-5 unit from the list of devices connected to your MFD's network.

1. Open **Network**

Homescreen > Settings > Network

2. Find and select the iTC-5 unit.
3. Select **Calibrate**.

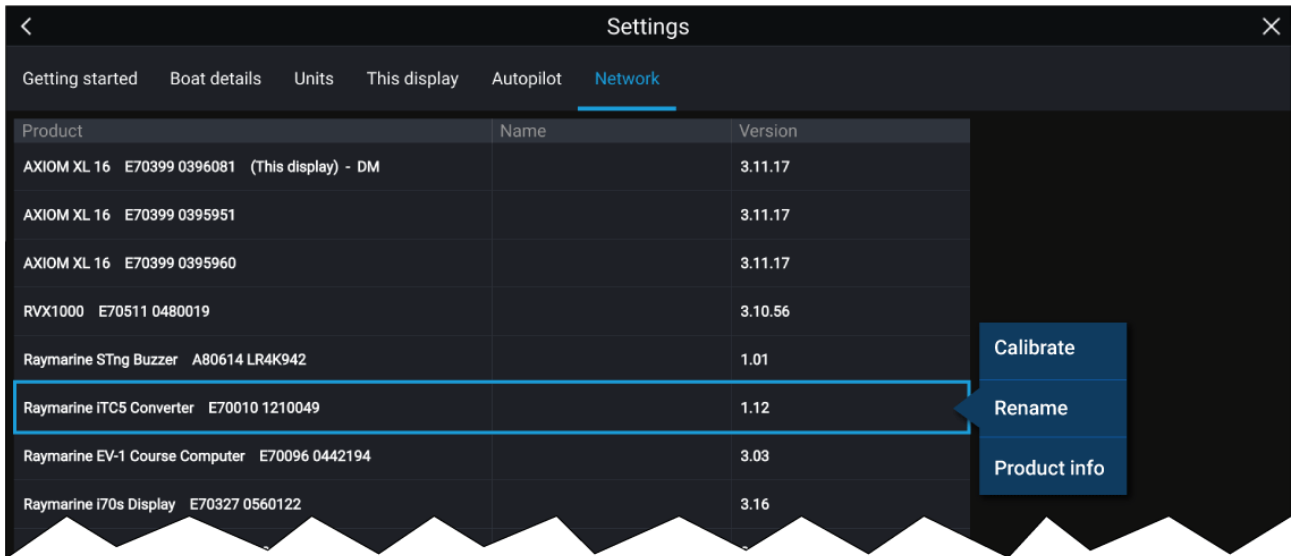

Data selection

You can choose which data type you want to calibrate:

- Depth
- Wind
- Speed

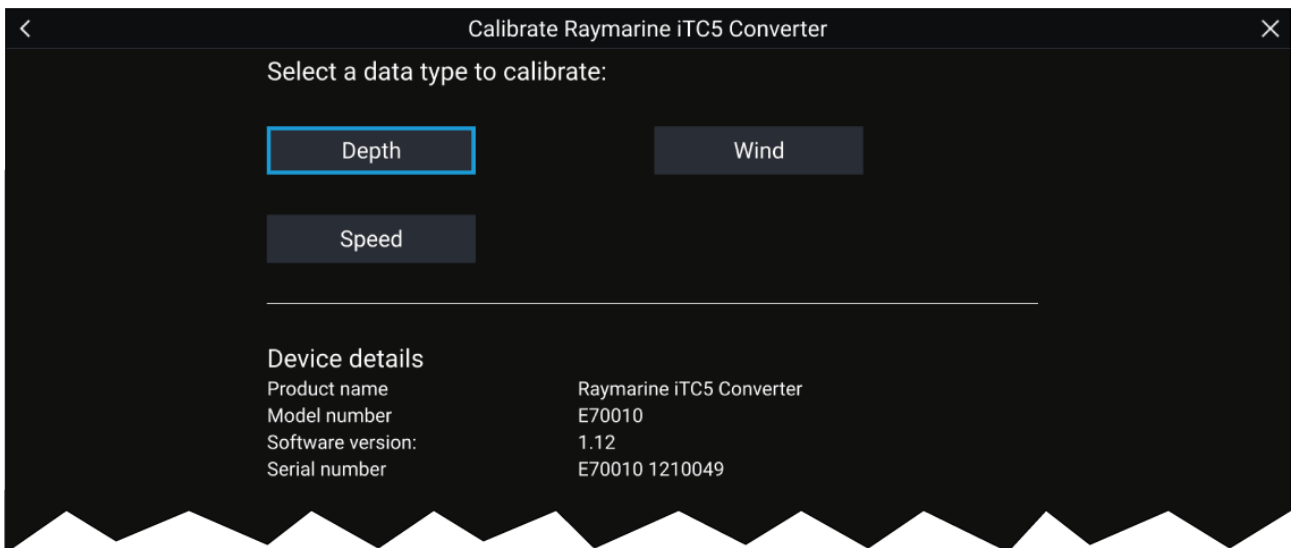



Depth

Calibrate your depth transducer.

Below keel	Enter the distance between the transducer face and the bottom of the keel.
Below waterline	Enter the distance between the bottom of your keel and the waterline.
Below transducer	No offset required.

Wind

Calibrate your wind transducer.

<p>Linearise transducer</p> 	<p>Turn your boat in a circle until all sectors have been calibrated (the ring turns green).</p>
<p>Align wind transducer</p> 	<p>Head your boat directly into observed wind to align.</p>
<p>Angle adjustment</p>	<p>Apply an offset to the angle.</p>
<p>Speed adjustment</p>	<p>Apply a scaling factor to apparent wind speed.</p>

Speed

Calibrate your speed transducer.

<p>Note: For best results, ensure that there is minimal or no tide/current effect when calibrating speed through water.</p>	
<p>Set STW to SOG</p>	<p>Apply a scaling factor to all STW readings, based on the present difference between STW and SOG.</p>
<p>Adjust STW</p>	<p>Apply a scaling factor to all speed through water values.</p>

Assigning a function to the User Programmable Button (UPB)

You can assign a function to the User Programmable Button on an Axiom™ Pro MFD.

1. Press and hold the **User Programmable Button** on the MFD.
2. Select the required function from the list.

You can also assign a function to the **User Programmable Button** from the Settings menu:
Homescreen > Settings > This Display > User Configurable Key.

Performing a settings or factory reset

Performing a **Factory reset** will erase ALL user data and reset the display's settings to their Factory default values. Performing a **Settings reset** will restore your display's settings to factory defaults, whilst retaining user data.

1. Select **Settings reset**, from the **This display** menu: **Homescreen > Settings > This display > Settings reset** to perform a settings reset.
2. Select **Factory reset**, from the **This display** menu: **Homescreen > Settings > This display > Factory reset** to perform a factory reset.

Importing user data

You can import user data (i.e.: Waypoints, Routes and Tracks) to your MFD.

1. Insert the MicroSD card that contains your user data files into a card reader slot on your MFD or connected card reader.
2. Select **Import from card** from the Import/export page: (**Homescreen > My data > Import/export > Import from card**).
3. Select the relevant SD card slot from the file browser and then navigate to your User data file (.gpx).
4. Select the relevant GPX file.
Your user data has now been imported.
5. Select **OK**.

4.6 Shortcuts

The Shortcuts menu can be accessed by swiping left to right across the **Power** button swipe area on an Axiom™ or Axiom™ XL MFD, or by pressing the **Power** button on an Axiom™ Pro , eS Series or gS Series MFD.

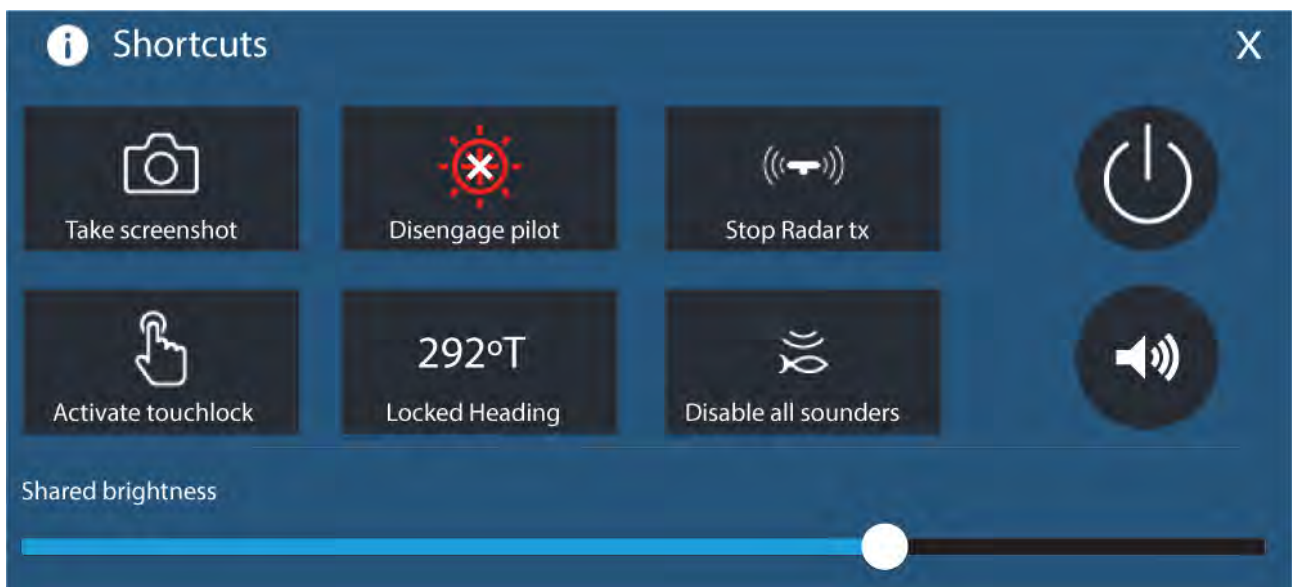

The following shortcuts are available:

- Take Screenshot
- Activate Touchlock
- Engage / Disengage autopilot
- Adjust Locked heading
- Stop Radar transmitting
- Disable all Sounders
- Power off
- Adjust Bluetooth speaker volume
- Adjust Brightness

Taking a screenshot

You can take a screenshot and save the image to external memory.

1. Swipe your finger from left to right across the **Power** button swipe area (applies only to Axiom™ or Axiom™ XL MFDs). Alternatively, press the **Power** button momentarily.

The Shortcuts menu is displayed.

2. Select **Take screenshot**.

The screenshot will be saved in .png format to the **Screenshot file** location. The Screenshot file location can be selected from the **This Display** tab located in the **Settings** menu: **Homescreen > Settings > This Display > Screenshot file**.

Note:

Due to protected content restrictions you cannot take a screenshot when the video input on an Axiom™ Pro or the Video 2 or HDMI input on an Axiom™ XL MFD is displayed onscreen.

Activating touchlock

In rough weather conditions precipitation may lead to erroneous touches being detected by the touchscreen. In these conditions you can use touchlock to prevent this.

1. Select **Activate touchlock** from the **Shortcuts** menu.

*With touchlock activated the touchscreen will be disabled. To re-enable the touchscreen, swipe from left to right across the **Power** button swipe area.*

Radar standby

You can place a transmitting Radar in Standby from the Shortcuts menu.

1. Select **Stop Radar tx** from the **Shortcuts** menu.

Autopilot shortcuts

When Autopilot control is enabled, the Shortcuts page provides an Autopilot icon which can be used to engage and disengage your autopilot. When the autopilot is engaged in Locked heading mode you can also adjust the locked heading from the Shortcuts page.

Adjusting brightness

LCD brightness can be adjusted from the Shortcuts page.

With the Shortcuts page displayed (accessible via the Power button):

1. Move the **Display brightness** control along the slider bar to adjust the brightness.

*With the Shortcuts menu displayed you can also use the **Power** button or the **Power** button swipe area to increase the brightness level in increments, by repeating the left to right swipe. Please note, the swipe area is only available on Axiom™ or Axiom™ XL displays.*

Disabling all sounders

In systems with multiple sonar modules, you can stop all sonar modules from pinging.

1. Select **Disable all sounders** from the shortcuts menu.

Bluetooth volume control

When your MFD is connected to a Bluetooth speaker, controls will be available to adjust speaker volume.

Homescreen



From the Homescreen select the Status area and then select the Speaker symbol to display the Bluetooth volume control for LightHouse™ app and MFD alarms.

Shortcuts page

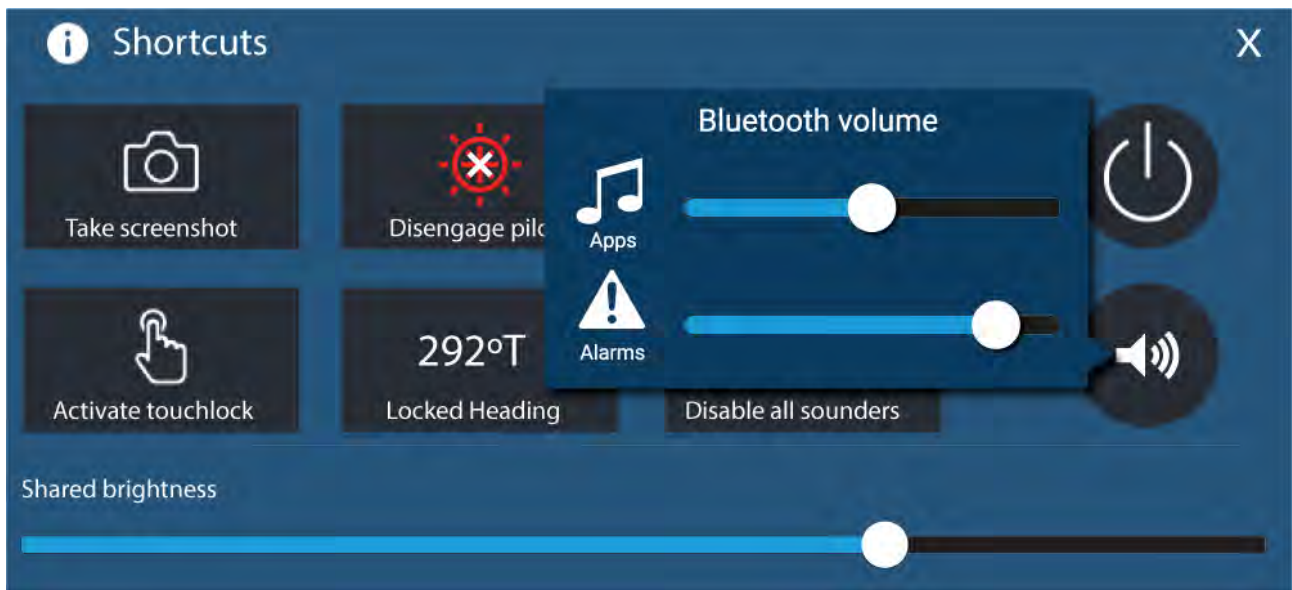

Press or swipe the **Power** button to display the Shortcuts page and then select the speaker symbol to display the Bluetooth volume control for LightHouse™ apps and MFD alarms.

4.7 Memory card compatibility

MicroSD memory cards can be used to backup / archive data (e.g. Waypoints, Routes and Tracks). Once data is backed up to a memory card, old data can be deleted from the system. The archived data can be retrieved at any time. It is recommended that your data is backed up to a memory card on a regular basis.

Compatible cards

The following types of MicroSD cards are compatible with your MFD:

Type	Size	Native card format	MFD supported Format
MicroSDSC (Micro Secure Digital Standard Capacity)	Up to 4GB	FAT12, FAT16 or FAT16B	NTFS, FAT32
MicroSDHC (Micro Secure Digital High Capacity)	4GB to 32GB	FAT32	NTFS, FAT32
MicroSDXC (Micro Secure Digital eXtended Capacity)	32GB to 2TB	exFAT	NTFS, FAT32

- **Speed class rating** — For best performance it is recommended that you use Class 10 or UHS (Ultra High Speed) class memory cards, or better.
- **Use branded memory cards** — When archiving data it is recommended that you use good quality branded memory cards.

Caution: Care of chart and memory cards

To avoid irreparable damage to and / or loss of data from chart and memory cards:

- Ensure that chart and memory cards are fitted the correct way around. DO NOT try to force a card into position.
- DO NOT use a metallic instrument such as a screwdriver or pliers to insert or remove a chart or memory card.

Removing MicroSD card from its adaptor

MicroSD memory and cartography chart cards are usually supplied inserted into an SD card adaptor. The card will need to be removed from the adaptor before inserting into your display.

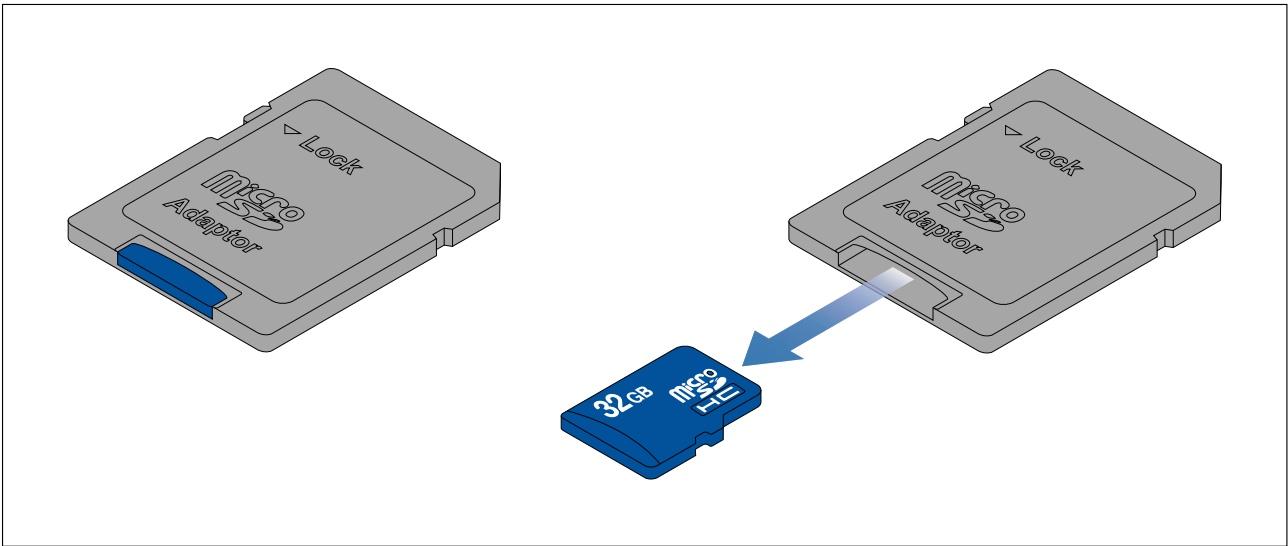

Inserting a MicroSD card — Axiom variants

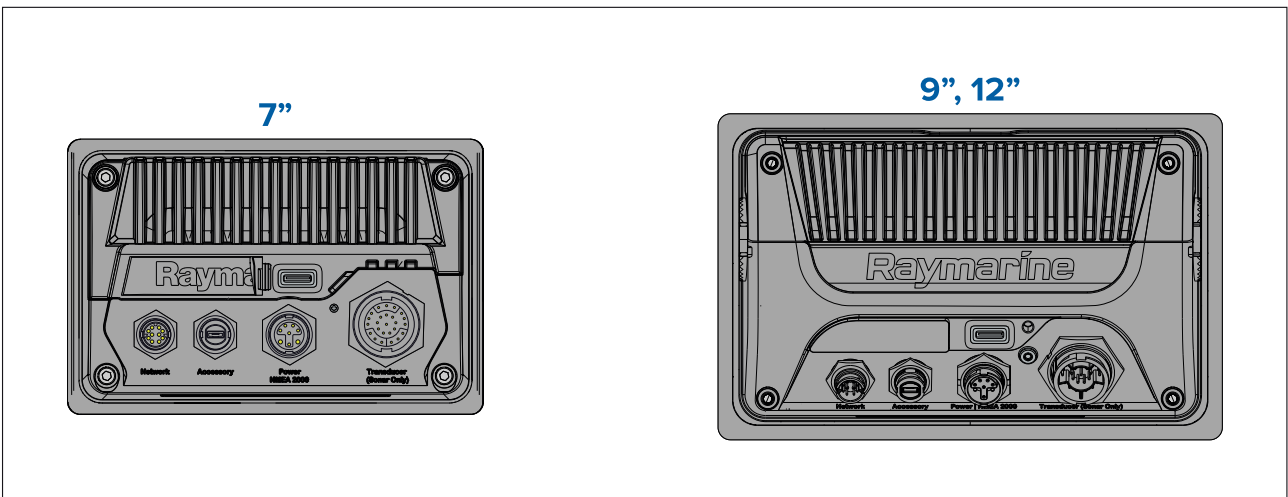

1. Pull back the microSD card reader cover as shown above.
2. Insert your microSD card with the contacts facing down.
3. Close the cover and ensure it is seated correctly.

Removing a MicroSD card

1. Select **Eject SD card** from the **Import/export** page: **Homescreen > My data > Import/export > Eject SD card.**
2. Remove the MicroSD card from the Rear of the MFD.
3. Ensure you close the card reader's cover.

Inserting a MicroSD card — Axiom Pro variants

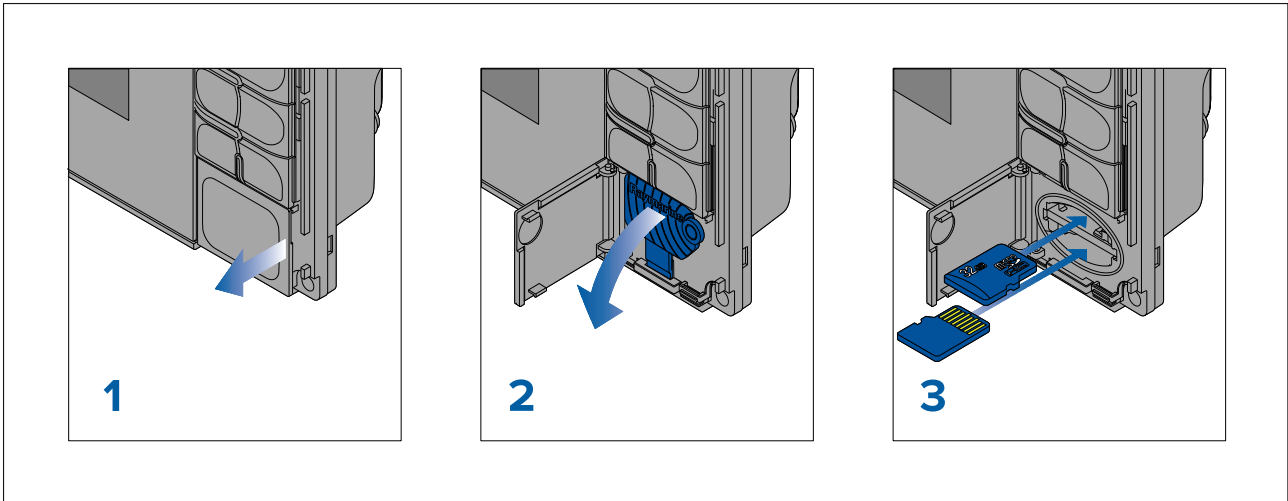

1. Open the card reader door.
2. Pull down the card reader cover.
3. Insert the card into a card slot and push until it clicks into place.

Note: When inserting a card into the lower card slot the memory card must be orientated with the contacts pointing upwards.

Removing a MicroSD card - Axiom Pro

With the card reader door open and cover pulled down:

1. Push the card in until it clicks.
2. Pull the card free from the card slot.

Inserting external storage devices - RCR

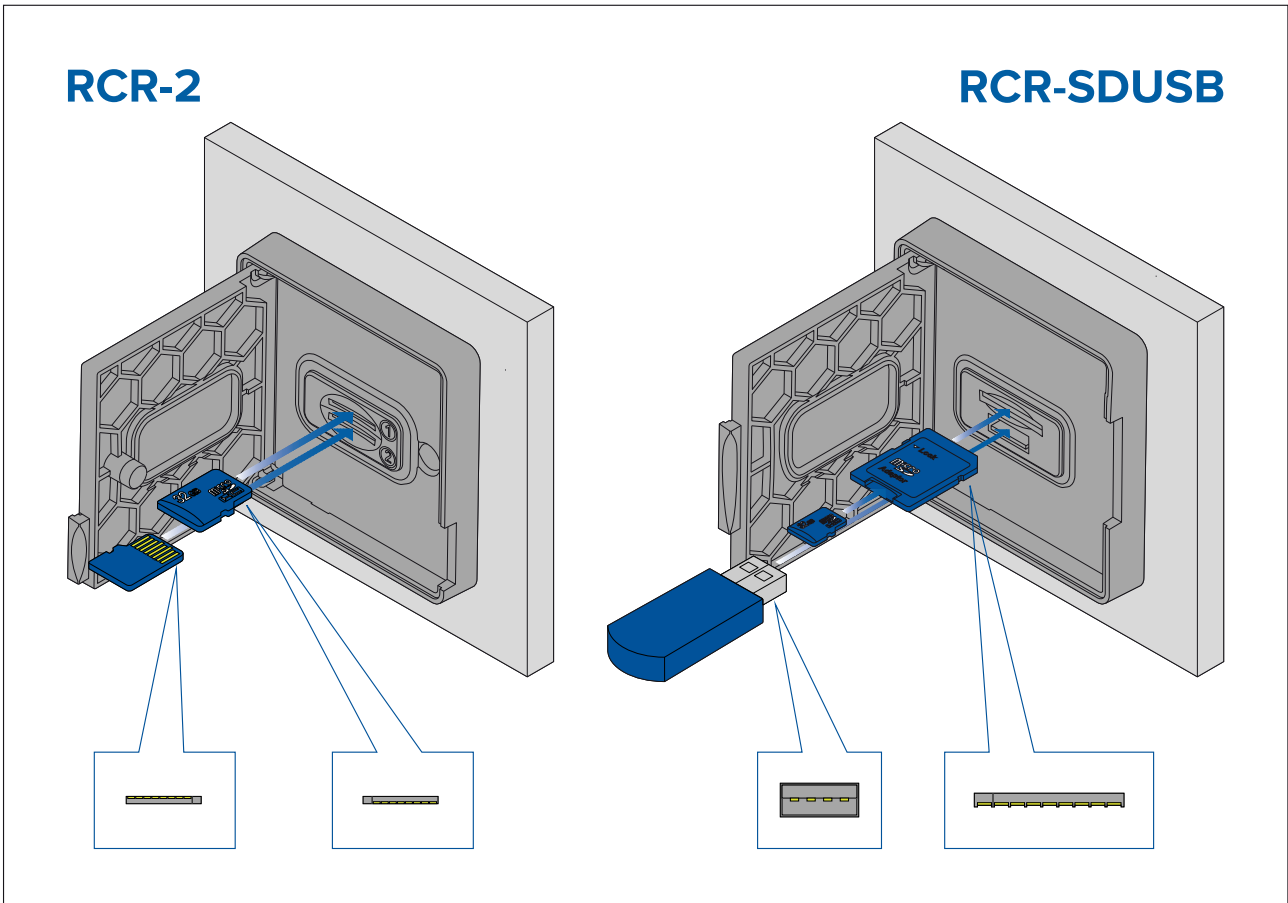

1. Open the card reader door.
2. Insert the storage device into a card slot and push until it clicks into place.

- RCR-SDUSB slot 1 — With the contacts facing down, insert an SD card (or an SD card adaptor containing a MicroSD card) into the upper slot, labelled (1), and push until it clicks into place.
- RCR-SDUSB slot 2 — With the contacts facing down, insert a USB drive directly into the lower slot, labelled (2).
- RCR-2 slot 1 — With the contacts facing down, insert a MicroSD card into the upper slot and push until it clicks into place.
- RCR-2 slot 2 — With the contacts facing up, insert a MicroSD card into the lower slot and push until it clicks into place.

Removing external storage (SD and MicroSD)

With the card reader door open:

1. Push the card in until it clicks.
2. Pull the card free from the card slot.

Removing external storage USB drive

With the card reader door open and cover pulled down:

1. Pull the drive free from the card slot.

Caution: Ensure card reader cover or door is securely closed

To prevent water ingress and consequent damage to the product, ensure that the card reader door or cover is firmly closed.

4.8 Software updates

Raymarine® regularly issues software updates for its products which provide new and enhanced features and improved performance and usability. It's important to ensure that you have the latest software for your products by regularly checking the Raymarine® website for new software releases.

www.raymarine.com/software

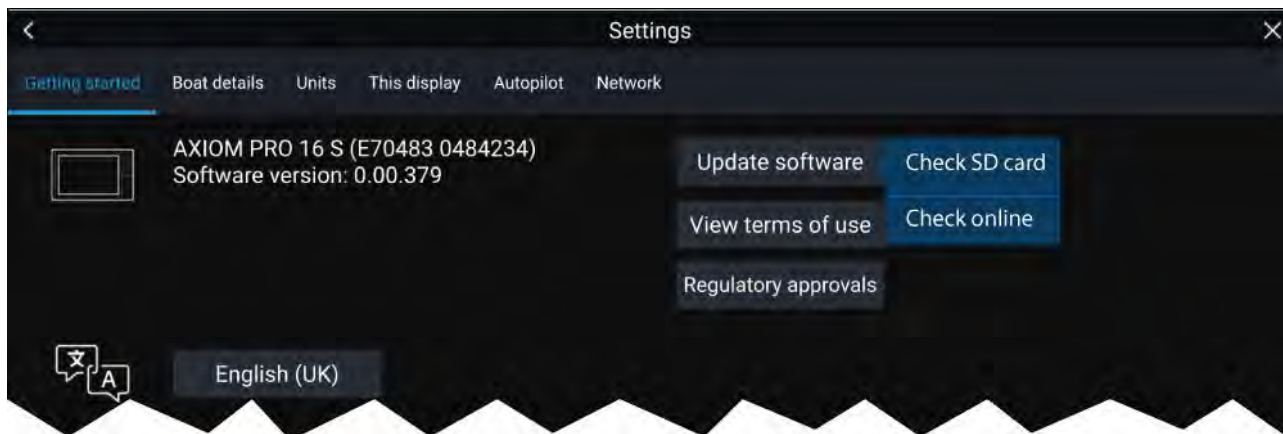

Note:

- It is recommended that you always backup your User data before performing a software update.
- To update compatible SeaTalkng® products you must use the designated Datamaster MFD that is physically connected to the SeaTalkng® backbone.
- In order to perform a software update any connected autopilot or Radar must be switched to Standby.
- The MFD's "Check online" feature is only available when the MFD has an Internet connection.
- To check which products are compatible with the MFD software update process, please refer to the website: www.raymarine.com/software.

Updating software using a memory card

Compatible SeaTalkhs® and SeaTalkng® products can be updated by following the steps below.

1. Check the software version of your product.

Refer to the documentation supplied with your product for information on checking software version.

2. Check the latest available software on the Raymarine website: (**www.raymarine.com > Support > Software Updates**).
3. Download the software package.
4. Copy the files to MicroSD card.
5. With your MFD powered on, insert the MicroSD card into the card reader slot.
Your MFD will automatically detect software files.
6. Follow the onscreen instructions to update your product software.
7. Alternatively you can select **Check SD card** from the **Update software** pop-over options on the Getting started tab: (**Homescreen > Settings > Getting started > Update Software**).

Updating software via the internet

Compatible SeaTalkhs® and SeaTalkng® products can be updated by following the steps below.

1. Select **Update software** from the Getting started tab: (**Homescreen > Settings > Getting started**).
2. Select **Check online** from the pop-over menu.
3. To set up a Wi-Fi connection select **Wi-Fi settings** and connect to the required Wi-Fi access point/hotspot.
4. Select **Start** and then follow any onscreen instructions.

4.9 Device pairing

Pairing a RMK remote keypad

You can control your MFD with an RMK keypad.

From the **This display** tab of the **Settings** menu: **Homescreen > Settings > This display** .

1. Select **Pair keypad**.
2. Follow the onscreen instructions to pair your keypad.

Ensure you select the correct orientation for the keypad during the pairing process.

3. Repeat steps 1 and 2 on each MFD you want to control from your keypad.

Note:

Please refer to the controls section of your keypad's documentation for details on controlling MFDs using a keypad.

Clear pairing (RMK)

1. Select **Clear pairings** to unpair ALL RMK keypads currently paired with the MFD.

Pairing with a Quantum Radar scanner

You can connect a Quantum Radar scanner to your MFD using Wi-Fi.

Pre-requisites:

- Ensure you have connected your Quantum Radar scanner in accordance with the instructions provided with the Radar scanner.
 - Ensure you know your Radar scanner's SSID and passcode.
1. Select **Pair with Quantum** from the **This display** tab: **Homescreen > Settings > This display > Pair with Quantum**.
 2. Follow the onscreen instructions to pair with your Quantum Radar.

The pairing process may take several minutes to complete.

For more information on the Quantum Radar pairing process (including troubleshooting information), refer to the Quantum Radar Installation instructions documents.

Pairing a Bluetooth speaker

Before attempting to pair with a Bluetooth speaker, ensure that the speaker is switched on and discoverable.

With your MFD's Bluetooth enabled:

1. From the Bluetooth settings page, select the relevant device from the **Available devices** list.
2. If requested, confirm the bluetooth pairing code.

If pairing is successful the speaker will appear in the **Paired devices** list and display the **Connected** message.

Chapter 5: Homescreen

Chapter contents

- 5.1 Accepting the Limitations on Use on page 52
- 5.2 Homescreen overview on page 52
- 5.3 MFD Apps on page 53
- 5.4 Creating / Customizing an App page on page 55
- 5.5 User profiles on page 56
- 5.6 Status area on page 58
- 5.7 Satellite navigation / positioning on page 60
- 5.8 My data on page 61
- 5.9 Secure messaging on page 65
- 5.10 Alarms on page 68
- 5.11 Man Overboard (MOB) on page 74
- 5.12 Settings on page 75
- 5.13 Connecting to a wireless display on page 85

5.1 Accepting the Limitations on Use

After your MFD has powered up the Homescreen is displayed.

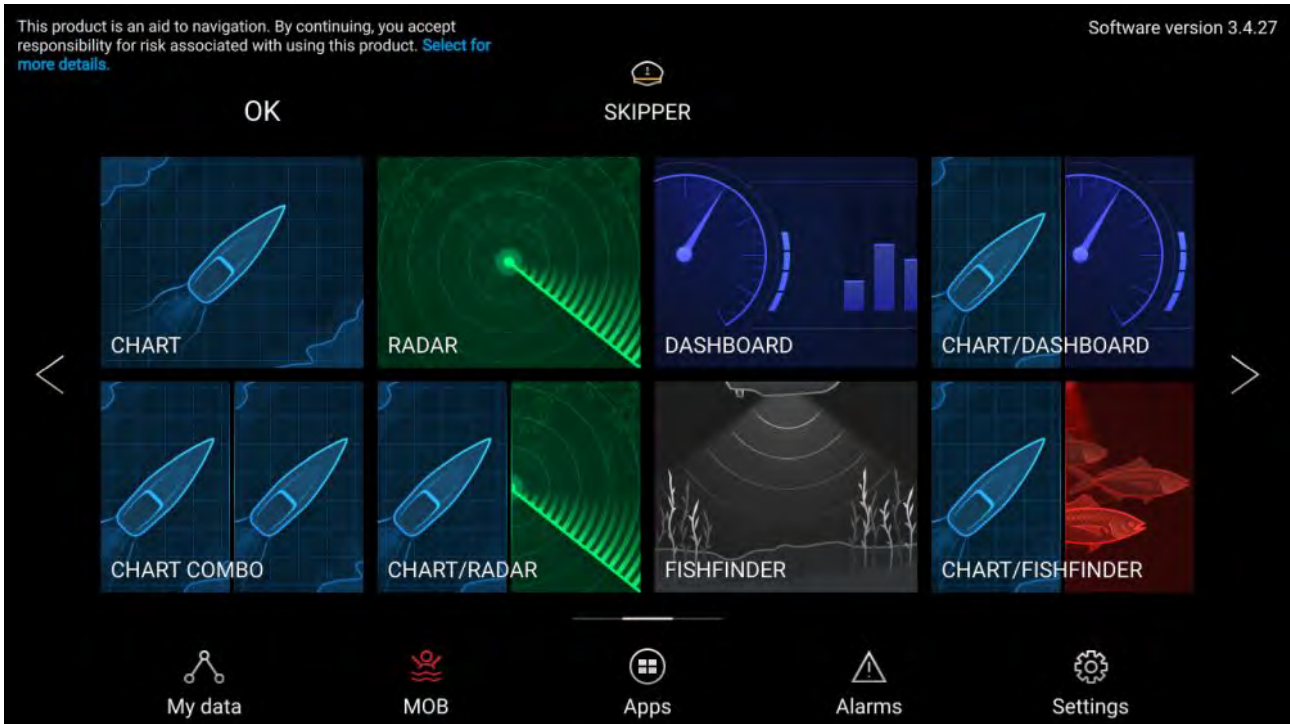

1. Before using the MFD you must accept the Limitations on Use (LoU) disclaimer. To view the full LoU Disclaimer, select 'more details'.

*The LoU acknowledgment is displayed each time the display is powered on and for each new user profile. The full LoU text can be accessed at any time from the **Getting started** tab: **Homescreen > Settings > Getting started > View terms of use.***

5.2 Homescreen overview

All settings and apps can be accessed from the Homescreen.

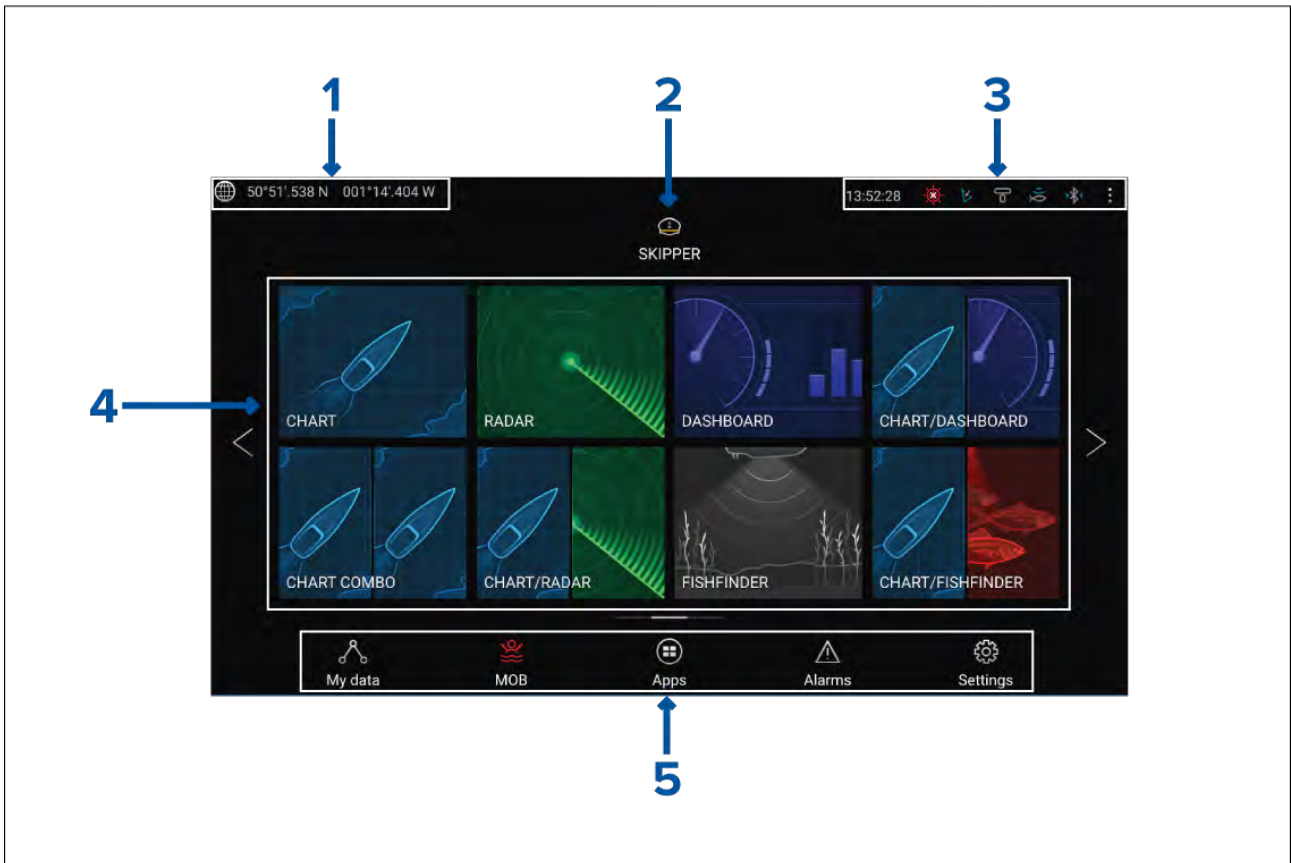







1. **GNSS position/fix details** — Select the area to view fix accuracy and access GNSS settings.
2. **Profile** — Select the area to change the profile in use or to create, edit or delete profiles.
3. **External devices and system time** — Select this area to access Bluetooth settings, Disengage your autopilot or adjust the UTC time offset.
4. **App page icons** — Select an icon to open the relevant MFD app page. Use the **Left** and **Right** arrows , or swipe your finger left or right across the area to cycle through the available Homescreen pages.
5. **Settings and data** — This area provides access to the **Settings, Alarms, Apps** and **My data** menus. You can also activate the **Man Over Board (MOB)** alarm and disengage your autopilot.



Note:

When more than 1 display is connected to the same network, then the Homescreen of the MFD designated as Data Master will be mirrored on all MFDs.

5.3 MFD Apps

MFD apps are displayed on your MFD in App pages. Each app page is accessed from the app page icons on the Homescreen. App pages can include more than 1 app. The available MFD apps are:

 <p>CHART</p>	<p>Chart — The Chart app displays electronic cartographic information from your Chart cards and when used in conjunction with a GNSS receiver, plots your vessel's position. The Chart app can be used to mark specific locations using Waypoints, build and navigate Routes or keep a record of where you have been by recording a Track. For more information refer to p.105 — Chart app</p>
 <p>RADAR</p>	<p>Radar — The Radar app is a situational awareness aid that displays a graphical representation of your surroundings in relation to your vessel using the echo/target returns from a connected Radar scanner. The Radar app allows you to track targets and measure distances and bearings For more information refer to p.197 — Radar app</p>
 <p>FISHFINDER</p>	<p>Fishfinder — The Fishfinder app uses a connected sonar module and transducer to help you to find fish by building up an underwater view of bottom structure and targets in the water column covered by your transducer. For more information refer to p.183 — Fishfinder app</p>
 <p>AUDIO</p>	<p>Audio — The Audio app allows you to control audio from a connected compatible entertainment system. For more information refer to p.293 — Audio app</p>
 <p>VIDEO</p>	<p>Video — The Camera app allows you to control and view feeds coming from connected video equipment such as an IP camera or Thermal camera. For more information refer to p.259 — Video app</p>
 <p>DASHBOARD</p>	<p>Dashboard — The Dashboard app provides data readings from connected sensors and equipment. The Dashboard app is also used for controlling, configured, compatible, Digital Switching hardware. For more information refer to p.231 — Dashboard app</p>
 <p>YAMAHA</p>	<p>Yamaha — The Yamaha app provides data readings from connected Yamaha engines. For more information refer to p.245 — Yamaha app</p>

 <p>PDF VIEWER</p>	<p>PDF Viewer — The PDF Viewer app allows you to open PDF files located on your external storage. For more information refer to p.307 — PDF Viewer app</p>
 <p>UAV</p>	<p>UAV — The UAV (Unmanned Aerial Vehicle) app provides remote controls, settings and video display, including flight data for your compatible UAV device. For more information refer to p.311 — UAV (Unmanned Aerial Vehicle) app</p>

5.4 Creating / Customizing an App page

1. Press and hold on an existing App page icon to display pop-over options.

You can Customize, Rename or Delete app pages from the pop-over options.

2. Select **Customize** from the pop-over options to change page layout and apps used. To Create a new page press and hold on a blank space on the Homescreen.

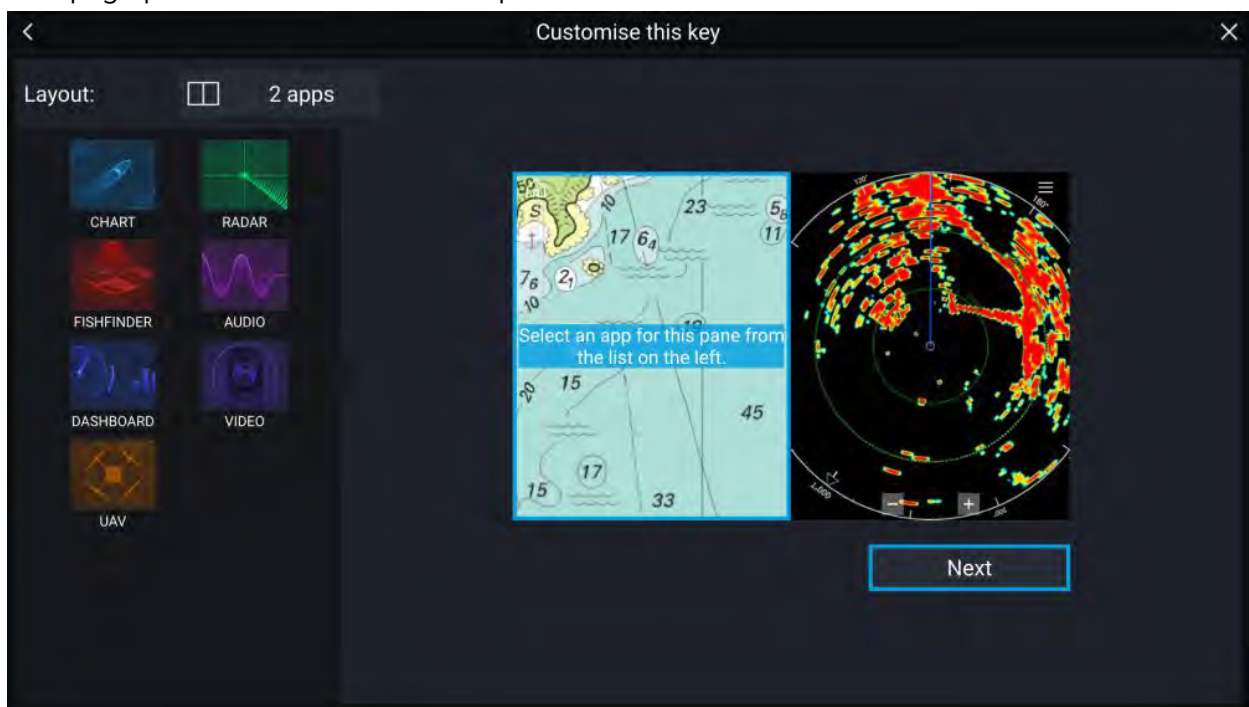

3. Select the **Layout:** option to change the page layout.
4. Select the icons for the Apps that you want to be displayed on the page.
5. Select **Next** and give the page a memorable name.
6. Select **Save**.

The page is saved and the new App page icon will be shown on the Homescreen.

5.5 User profiles

You can share your MFD with other users by creating user profiles on your MFD. Profiles enable you to retain your own personal settings whilst letting other users personalize the MFD's settings to their preference.

Note:

User data such as Waypoints, Routes, Tracks, images and video recordings etc. will be available to all users, and are shared by all users. This means that, for example, if you add or delete a waypoint while using one user profile, the change will also be reflected in all other profiles on the MFD, including demo profiles.

You can access the Profiles page by selecting the Profile Icon on the Homescreen.

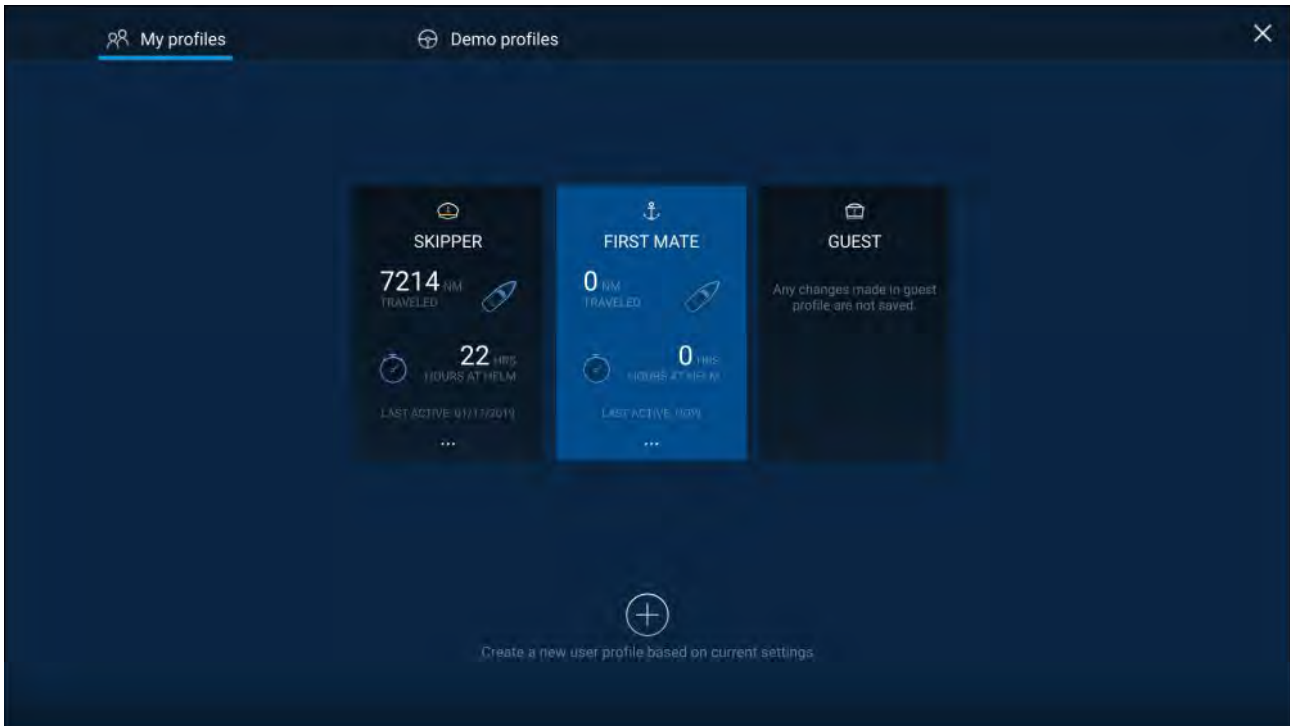

Selecting the **Plus (+)** icon will create a new profile based on the profile that is currently in use.

MFD settings changes are unique to the profile in use and are retained the next time the profile is used.

The distance and time that a profile has been active is displayed for each profile.

Profile names and icons can be customized. You can also reset the distance and time for each profile.

A Guest profile is available for temporary users. Setting changes to the Guest profile are not retained. Each time the Guest profile is activated the settings are based on the last used profile.

When the MFD is rebooted the last used profile will be active.

Demo profiles are also available to help you practice operating your MFD with simulated data.

Demo profiles

Profiles are available for simulation and demonstration purposes. A demo movie, stored on external storage, can also be set to play when a demo profile is activated and inactivity has been detected for 60 seconds.

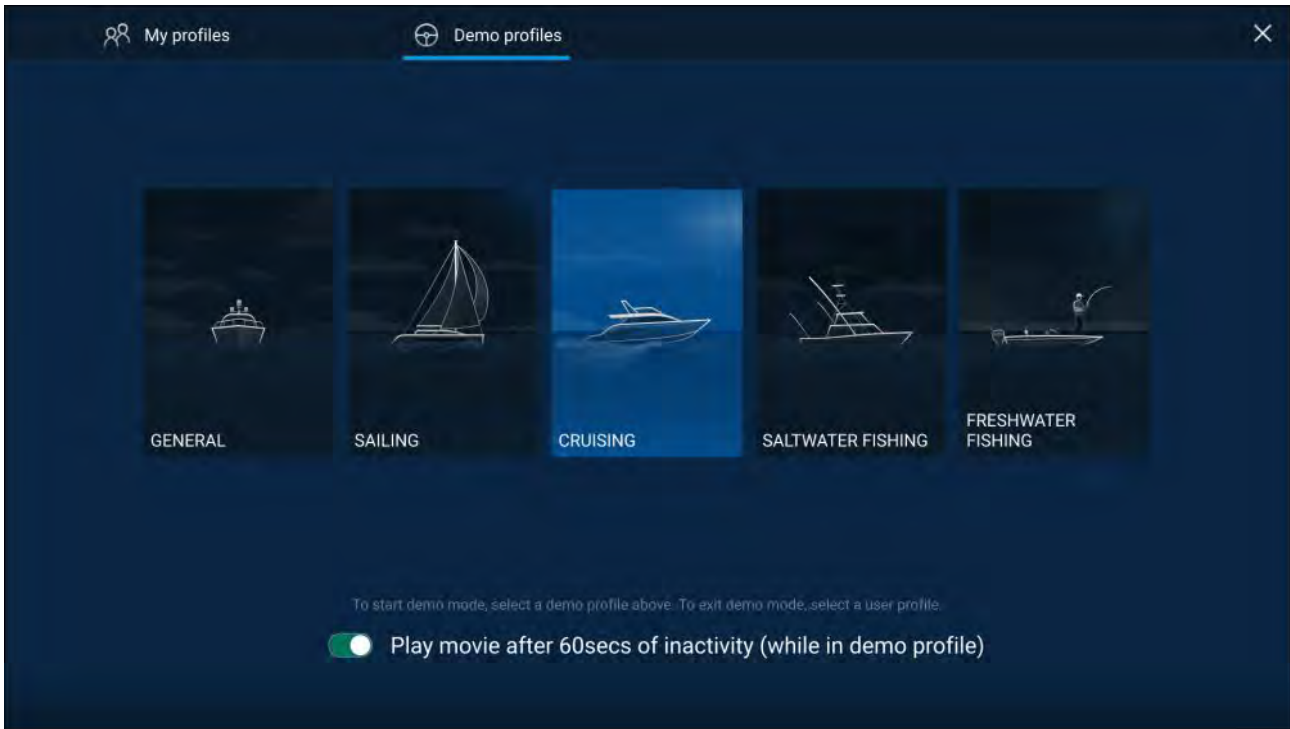

Selecting a Demo profile will provide your MFD with simulated data to help you practice operating your display.

Important:

- It is recommended that Demo profiles are NOT activated whilst navigating.
- User **data** such as Waypoints, Routes, and Tracks is shared with all the other user profiles on the MFD. This means that, for example, if you add or delete a waypoint while using a demo profile, the change will also be reflected in all other user profiles on the MFD.
- Demo profiles will NOT display any real data, including safety warnings and messages.
- Any **settings** changes made will not affect User profiles.

Demo movie requirements

A demo movie file can be set to play when a demo profile is active and the MFD has not been used for 60 seconds.

Demo movie files must be in the .mov file format and encoded using the H.264 video codec standard. The Demo movie files must be saved to an external storage device connected to the MFD. Demo movies are not shared across networked MFDs.

When the Demo movie feature is activated the system will search for a demo movie file associated with the active demo profile. If an associated file cannot be found then the generic demo.mov is played. See below for filename details.

Demo profile	Associated filename
General	demo_general.mov
Sailing	demo_sailing.mov
Cruising	demo_cruising.mov
Saltwater fishing	demo_salt.mov
Freshwater fishing	demo_fresh.mov
Plays in all demo profiles if an associated demo file is not found.	demo.mov

If an MFD is powered off with the demo movie active then the next time the MFD is powered on the demo movie will play immediately after boot up.

Any interaction with the Touchscreen or physical buttons will stop the movie playing and return you to the active demo profile.

5.6 Status area

You can view the status of connected peripheral devices using the MFD's Status area, located at the top right of the Homescreen. This area also displays the **Time** and identifies when the MFD is in **Touchlock** mode.

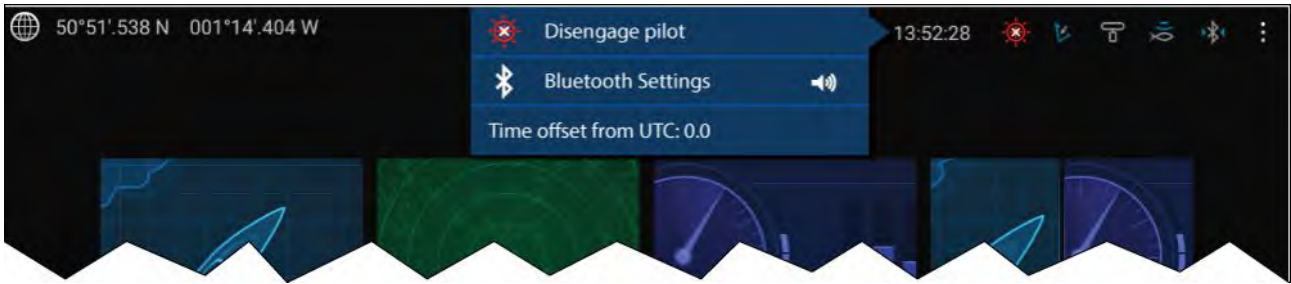

Status area icons

The status area provides icons which identify the status of connected Autopilot, AIS, Radar, Sonar/Transducer, and Bluetooth devices.

Pop-over menu options

From the **Options** pop-over you can:

- Disengage your autopilot.
- Access Bluetooth settings and volume controls.
- Adjust the Time offset from UTC.

Status area icons

The icons displayed in the Status area signify the current status of certain connected devices.



AIS

Icon	Status	Icon	Status
	AIS transmitting and receiving		AIS receive only (e.g. Silent Mode)
	AIS restricted (Requires AIS5000 transceiver)		AIS Error



Autopilot

Icon	Status	Icon	Status
	Autopilot engaged		



Bluetooth

Icon	Status	Icon	Status
	Bluetooth on / not connected		Bluetooth connected / paired

Radar

Icon	Status	Icon	Status
	Radar transmitting		Radar standby
	Radar error		

Sonar / Transducer

Icon	Status	Icon	Status
	Sonar pinging		Sonar not pinging
	Sonar error		

Touchlock

Icon	Status	Icon	Status
	Touchlock active		

5.7 Satellite navigation / positioning

GNSS (GPS) Status

Your vessel's GNSS (GPS) position is provided in the top left corner of the Homescreen. You can access fix accuracy and settings by selecting the area.

If latitude and longitude is displayed on the Homescreen, you have a valid position fix. If the text turns red, your fix accuracy is low.

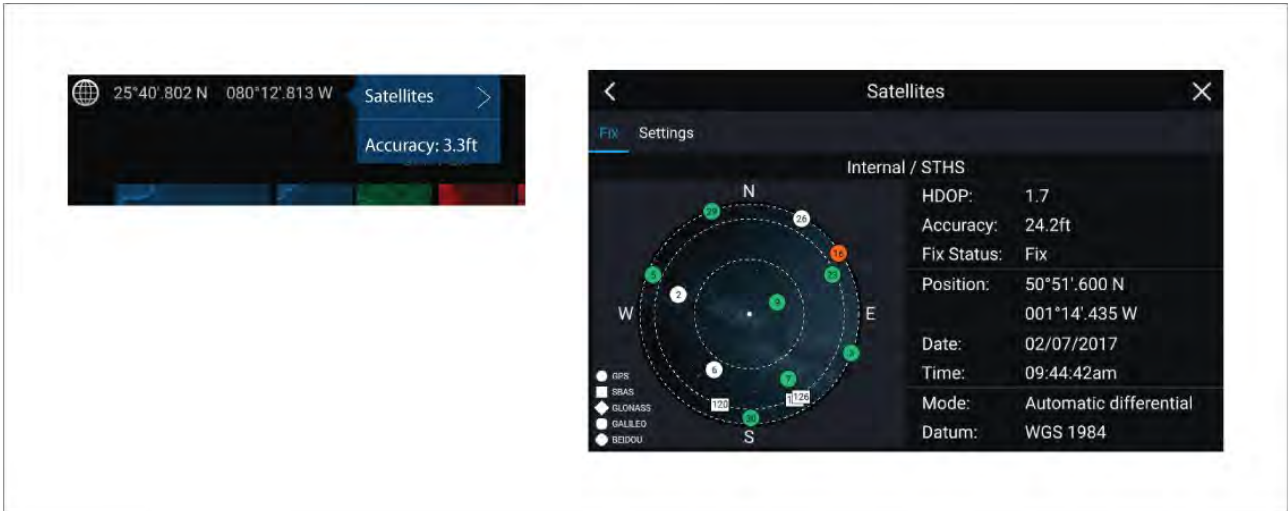

The sky view on the left side of the page shows the position of navigation satellites and the constellation they belong to. The color of the satellite identifies its status:

- Grey = searching for satellite.
- Green = satellite in use.
- Orange = tracking satellite.

GNSS (GPS) Settings

The settings for your GNSS (GPS) receiver (internal or external) can be accessed from the **Satellites** menu: **Homescreen > GNSS pop-over > Satellites > Settings**.

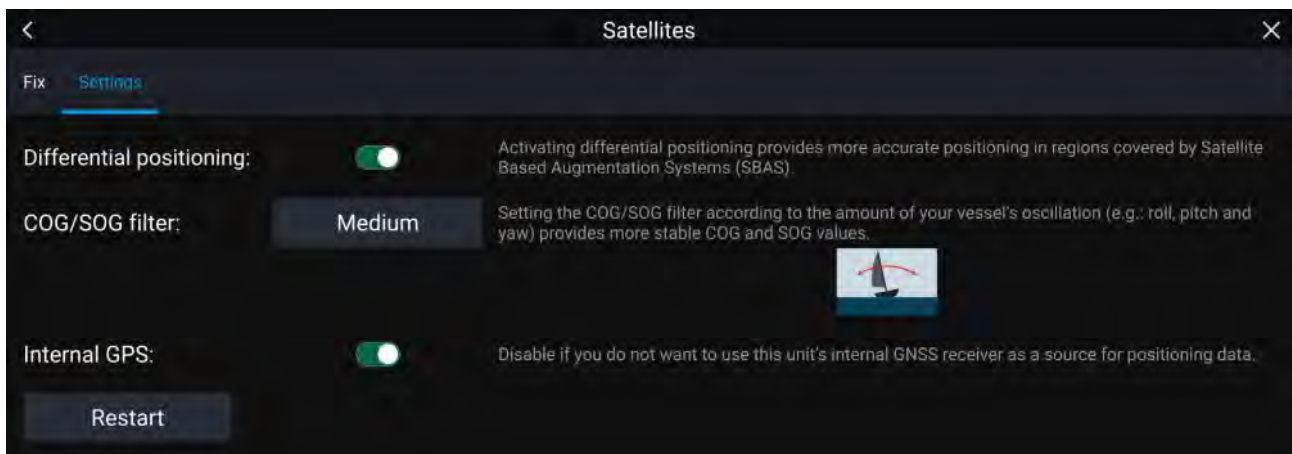

From the GNSS Settings tab you can:

- activate and deactivate use of Differential positioning (SBAS)
- set the COG/SOG filter according to your vessel's oscillation, which provides more stable COG and SOG readings
- enable and disable your MFD's internal GNSS (GPS) receiver. Disable it if you do not want to use this unit's internal GNSS (GPS) receiver as a source for positioning data.
- restart the GNSS (GPS) receiver that is being used as the source for your positioning data.

5.8 My data

Selecting **My data** from the Homescreen provides access to user data such as **Waypoints**, **Routes**, **Tracks**, **Fuel** and **Trip** data and also media **Files**. You can also **Import/export** User data and MFD settings.

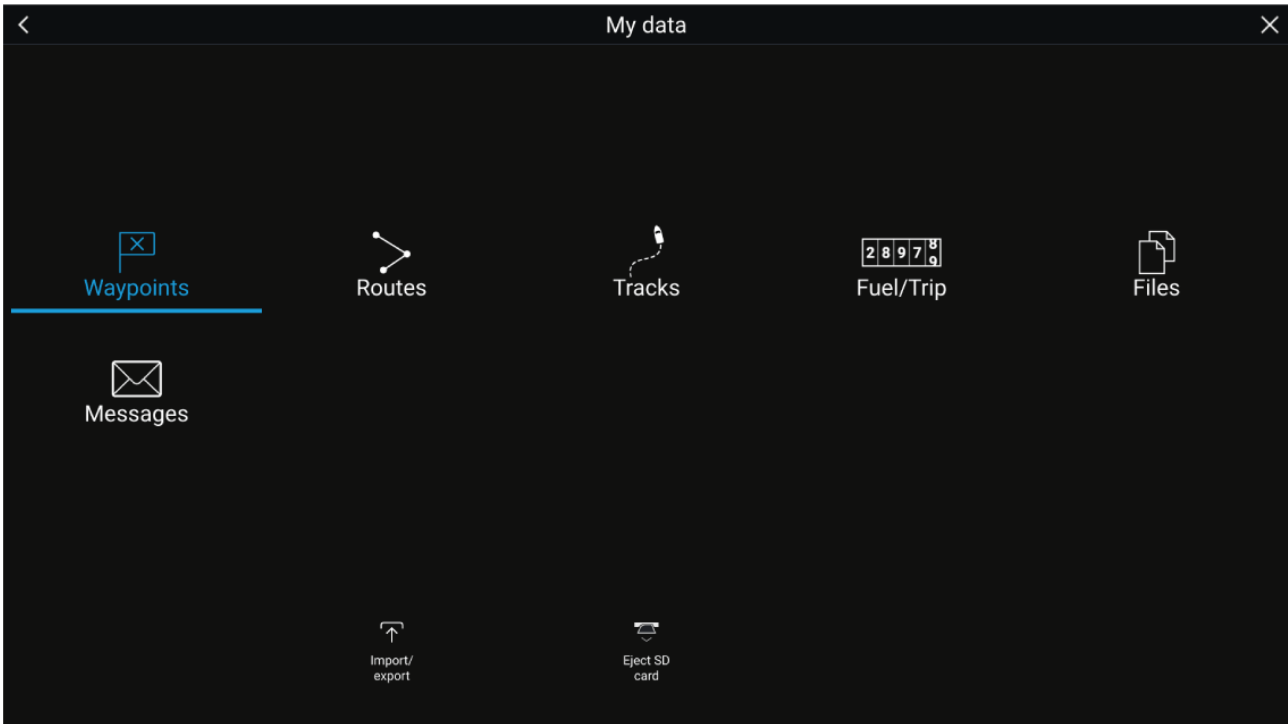

Selecting **Waypoints**, **Routes** or **Tracks** displays the relevant list, where you can manage and customize your data.

Selecting **Fuel/Trip** displays the Fuel manager and Trip counters.

Selecting **Files** opens a file browser.

Selecting **Import/export** allows you to backup or restore user data and MFD settings using an external storage device.

Selecting **Messages** opens a list of secure messages you have sent from your system, or received from other first responder vessels. This feature requires an AIS5000 unit on the system, and the Responder settings must also be configured correctly. For more information, refer to: [p.84 — Responder setup](#)

Fuel/trip manager

The fuel/trip manager collects trip data automatically based on distance travelled and provides an estimate of how much fuel you have remaining based on user inputted fuel refill data.

The Fuel/trip manager can be accessed by selecting **Fuel/Trip** from the **My Data** page: **Homescreen > My Data > Fuel/Trip**.

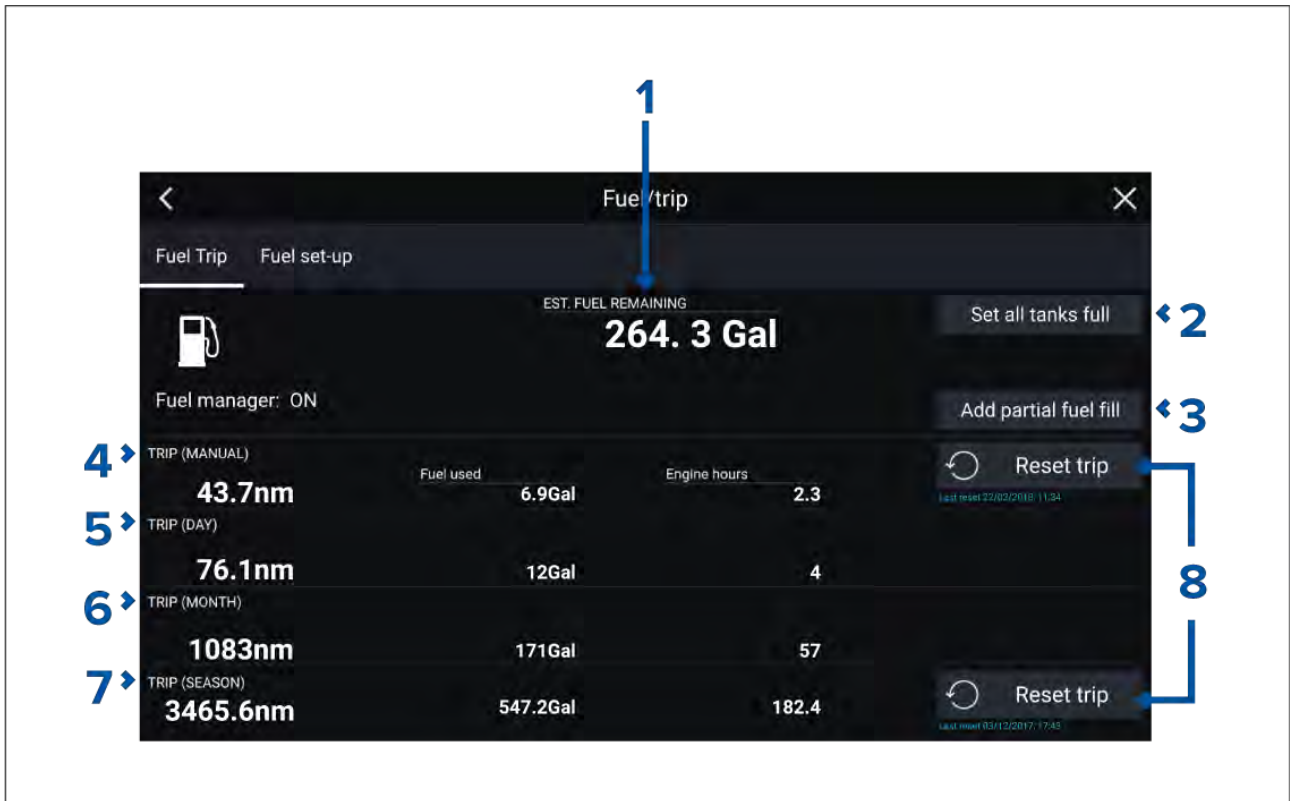

1. Estimated fuel remaining
2. **Set all tanks full** — Select when you have filled up all tanks.
3. **Add partial fuel fill** — Select to enter a specific volume of fuel during a partial tank fill.

Note: If you enter the wrong amount of fuel this can be corrected by entering a minus value as a partial fuel fill, this will reduce the total amount of fuel remaining by the amount entered.

4. Trip (Manual) — accumulates data until reset.
5. Trip (Day) — resets automatically when local time passes midnight.
6. Trip (Month) — resets automatically on the 1st day of the month.
7. Trip (Season) — accumulates data until reset.
8. **Reset trip** — The **Trip (Manual)** and **Trip (Season)** logs can be reset by selecting the relevant **Reset Trip** button.

Note:

- The Fuel manager estimates the amount of fuel remaining onboard based on logging each time you fill up, your vessel’s total fuel capacity, and how much fuel is burned by your engine(s). Incorrect entries will affect the fuel calculations which could result in a shortage of fuel.
- The Fuel remaining calculation is an estimate and will be inaccurate if fuel fills are not entered, entered incorrectly, or if fuel is used by other sources (e.g.: generators).
- Distance to Empty and Time to Empty values are based on estimated fuel remaining calculations which do not take into account the effects of weather and tide on fuel usage.
- This system is not a substitute for other fuel calculations. You should not rely on the Fuel manager calculations for accurate voyage planning or in emergency and safety critical situations.

Fuel set up

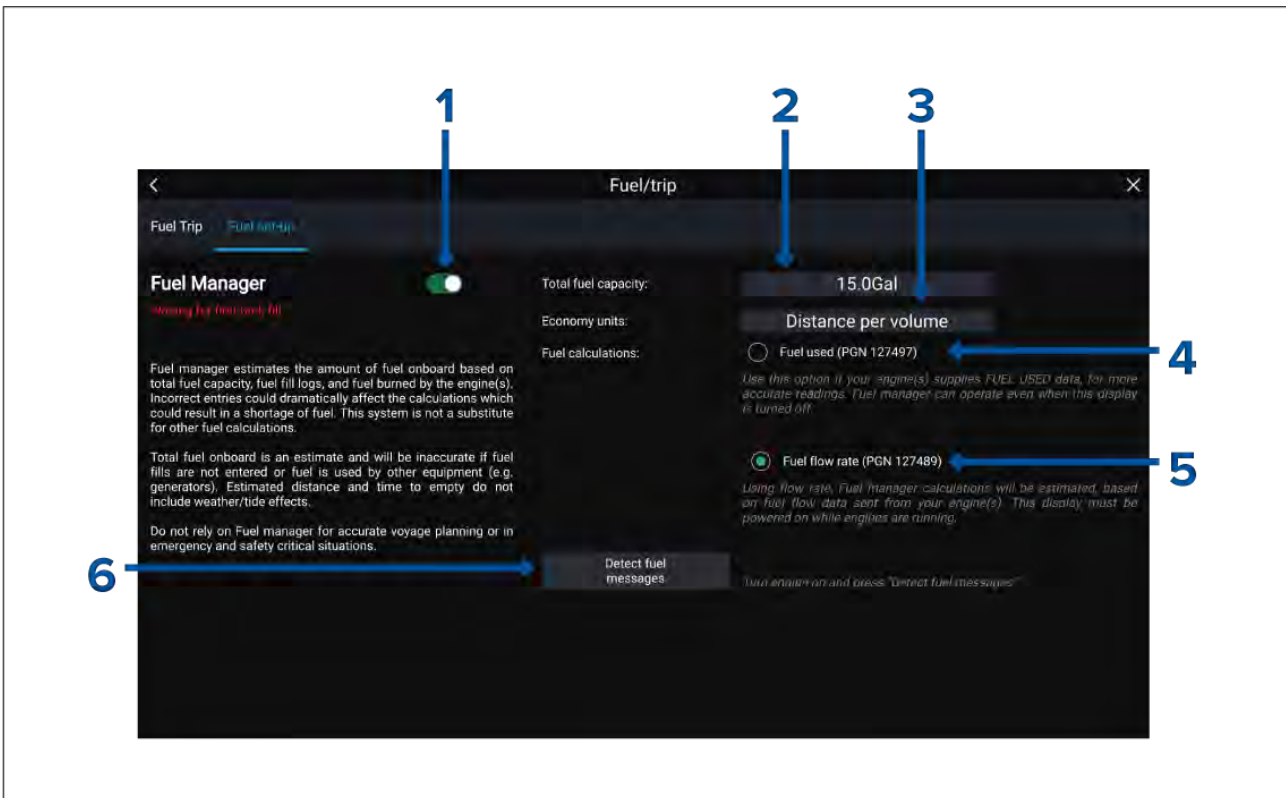

1. Enable/Disable Fuel manager.
2. **Total fuel capacity** — Sum of total capacity of all your fuel tanks.
3. **Economy units** — Economy units used in data overlays, Side bars or the Dashboard app.
4. **Fuel used (PGN 127497)** — Use this option if your engine(s) supply Fuel used data. When Fuel used is selected the Fuel manager will continue to operate when the MFD is switched off. This option usually provides more accurate readings.
5. **Fuel flow rate (PGN 127489)** — this option estimates fuel calculations based on fuel flow rate data sent by your engine(s). Your MFD must remain switched on, whilst engines are running.
6. **Detect fuel messages** — If you are unsure which engine messages your engine provides, select this option to determine the correct message.

Setting up the Fuel manager

To start using the Fuel manager you must first specify the total capacity of your fuel tanks, and then fill the tanks to set a reference level for the Fuel manager.

From the Fuel set-up page: **Homescreen > My Data > Fuel/Trip > Fuel set-up:**

1. Select the box next to **Total fuel capacity:** and enter the total capacity of all of your fuel tanks.
2. Select the **Fuel manager** toggle switch to enable the Fuel manager.
3. Select the box next to **Economy units:** and select either: Distance per volume, Volume per distance, or Litres per 100km.
4. Select either **Fuel used (PGN 127497)** or **Fuel flow rate (PGN 127489)**. If you are unsure, select **Detect fuel messages** to detect which messages are available to your MFD.
5. Fill up your fuel tanks.
6. Once the tanks are full, select **Set all tanks full** from the Fuel Trip page.
7. Log each subsequent fuel fill whether partial or full.

Files

The file browser can be used to **Open** and **Delete** photos / images and PDF documents, saved to external storage, and can also be used to **Import** or **Delete** user data and MFD settings files) saved to external storage.

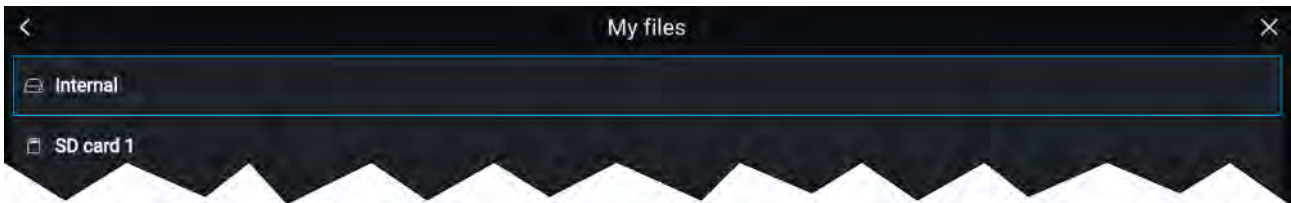

- Selecting a storage device expands its contents, allowing you to browse the contents.
- Selecting an image or PDF file provides pop-over options to open or delete the file.
- Selecting a user data (.gpx) or MFD settings (.lh3) file provides pop-over options to **Import** or **Delete** the file.

Note:

Only file types that are supported by your MFD will be visible in the browser.

View PDFs

PDF files can be viewed by opening them directly from the file browser or opening them using the PDF Viewer app. For more information on the PDF Viewer app refer to [Chapter 17 PDF Viewer app](#)

Import/export

User data and MFD settings can be imported and exported from your MFD. User data (Waypoint, Routes and Tracks) is saved in the common .gpx file format. MFD settings will be saved in .lh3 format. The Import/export page can be accessed from the My data page: **Homescreen > My data > Import/export**.

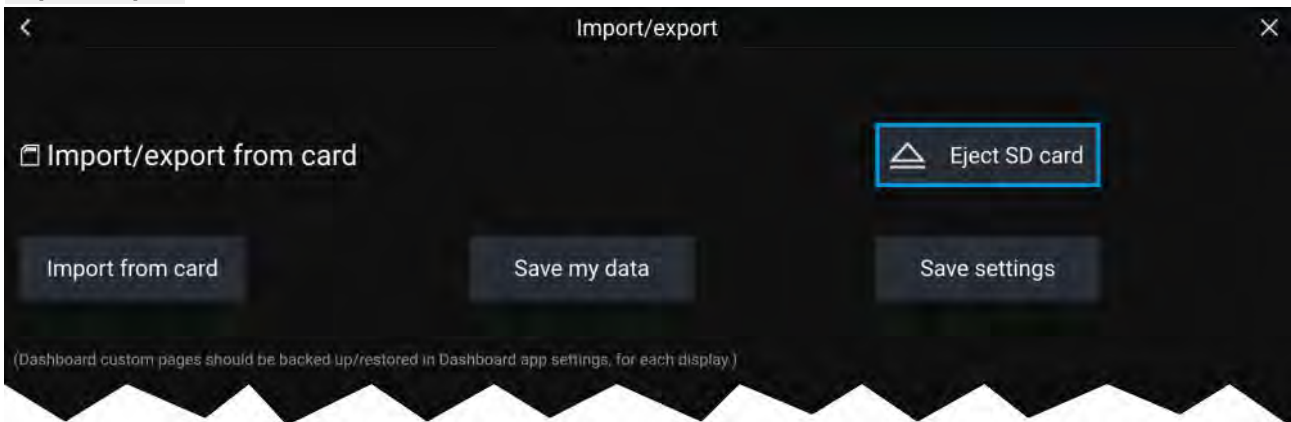

Saving user data (My data)

You can backup your user data (waypoints, routes and tracks) to a MicroSD card.

1. Insert a memory card into your display's card reader.
2. Select **Save data to card** from the Import/export page: **Homescreen > My data > Import/export**. A pop-over menu is displayed.
3. Select the desired option:
 - **Save all data** to save (export) all waypoints, routes and tracks.
 - **Save waypoints** to save (export) all waypoints.
 - **Save routes** to save (export) all routes.
 - **Save tracks** to save (export) all tracks.
4. Select **Save** to save the user data using the default filename. Alternatively:
 - i. Use the onscreen keyboard to enter your own filename and then select **Save**.
5. Select **OK** to return to the Import/export page, or select **Eject card** to safely remove the memory card.

The user data file is saved to the '\Raymarine\My Data\' directory of your memory card in gpx format.

Saving MFD settings

You can backup your MFD's settings to an external storage device, allowing you to restore your personalized MFD settings at a later date.

Important:

- Saving your MFD settings will also save any new or customized dashboard pages.
- Digital switching dashboard pages will not be saved when saving your MFD's settings.

1. Insert a memory card into a card reader slot on your MFD.
2. Select **Save settings** from the Import/export page: **Homescreen > My data > Import/export**.
3. Select the relevant card slot from the Info dialog.
4. Select **Save** to save the user data using the default filename. Alternatively:
 - i. Use the onscreen keyboard to enter your own filename and select **Save**.
5. Select **OK** to return to the Import/export page, or select **Eject card** to safely remove the memory card.

Importing user data or MFD settings from a memory card

You can restore user data (waypoints, routes and tracks) from an external storage device.

Important:

- Restoring your MFD settings will also restore any new or customized dashboard pages.
- Digital switching dashboard pages will not be restored when importing your MFD's settings.

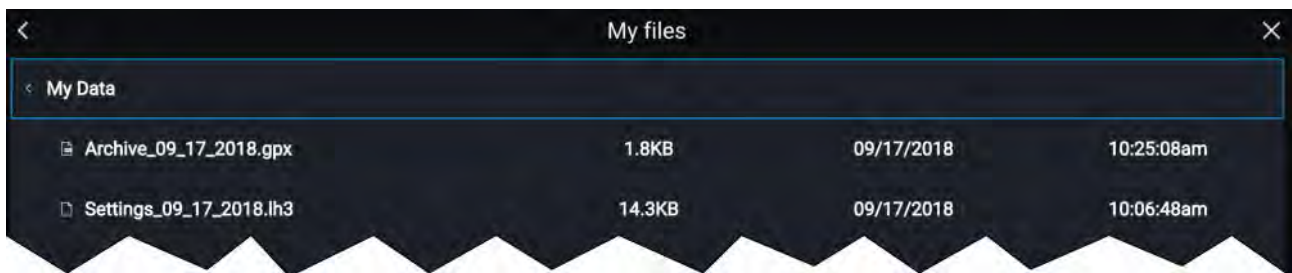

1. Insert the memory card containing your saved data into a card reader slot.
2. Select **Import from card** from the Import/export page: **Homescreen > My data > Import/export**.
The file browser is displayed
3. Navigate to the gpx or lh3 file that you want to import.

*User data and MFD settings files will be located in the **|Raymarine|My Data|** folder on your memory card.*

4. Select the file.
The import will commence.
5. If importing a gpx file, select **OK** when complete, alternatively
6. If importing MFD settings, select **Yes** to confirm restoring your MFD's settings.

Your MFD will reboot to complete the process.

5.9 Secure messaging

Vessels connected to an AIS5000 unit and set to responder activity upon initial setup can send and receive secure text messages with other properly equipped vessels via the **My data** tab

Homescreen > My data > Messages

Note:

For more information on responder setup refer to [p.84 — Responder setup](#)

Message inbox

The inbox stores all direct messages and broadcasts that you have sent and received from other responder vessels.

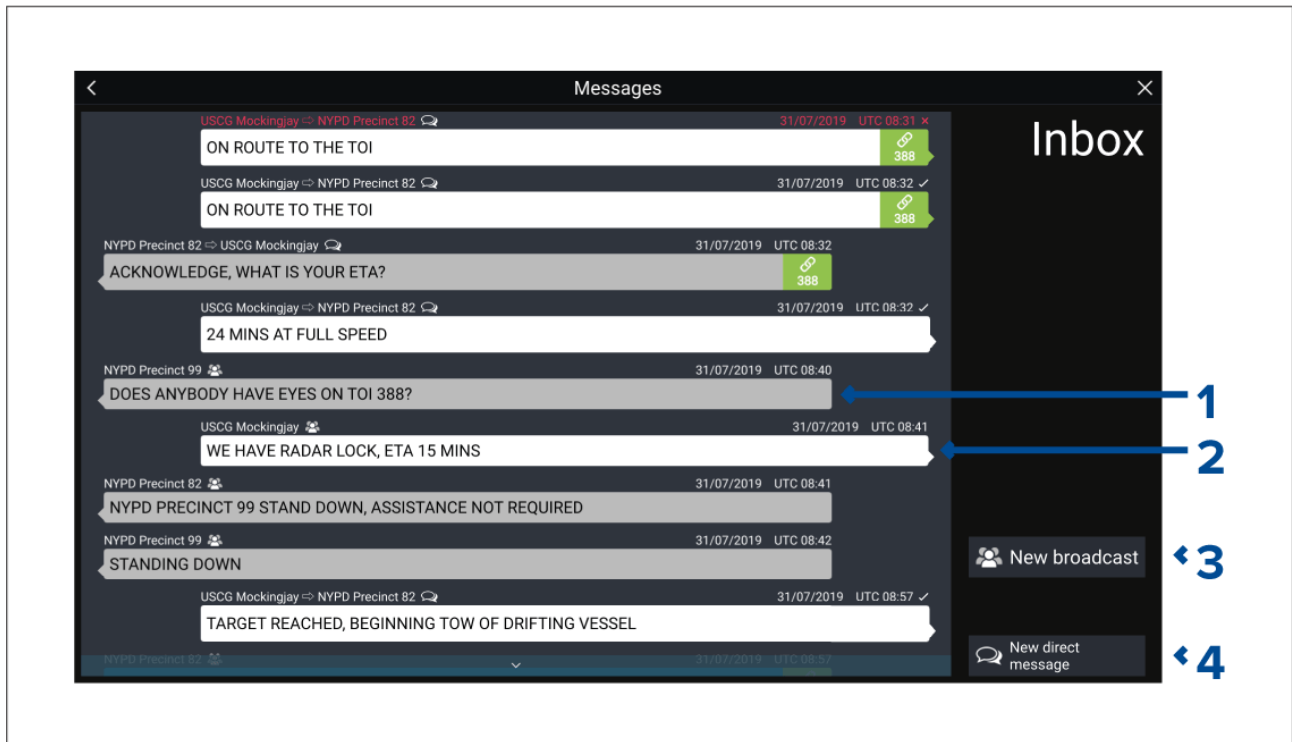

1. **Received** broadcasts and direct messages (grey, left side).
2. **Sent** broadcasts and direct messages (white, right side).
3. **New broadcast** — Send a broadcast to all responder vessels.
4. **New direct message** — Send a direct message to a specific responder vessel.

Note:

Messages older than 72 hours will be removed from the inbox after a power cycle.

New broadcast

Select **New broadcast** to send a broadcast to all responder vessels.

New broadcast opens the onscreen keyboard where you can type your broadcast message. When you are happy with your message select **Send** to broadcast the message.

New direct message

Select **New direct message** to send a direct message to a specific responder vessel.

New direct message opens the **Recipient** page where you can select **Recent** (recent message senders and recipients) contacts and **Buddy** contacts.

Choose a recent or buddy contact and select **Next** to proceed to the onscreen keyboard. When you are happy with your message select **Send** to send the message.

If a recipient is not a **Buddy** contact and does not appear in the **Recent** list, you can manually enter their **MMSI number** to send them a direct message.

Direct messaging within the Chart or Radar app

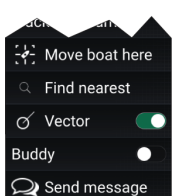

You can send direct messages to a Blueforce AIS target in the Chart or Radar apps. To do this, perform a long press on a Blueforce vessel and then select **Send message** from the context menu.

For more information on Blueforce AIS targets, refer to: [p.139 – Blue Force overview](#)

Reply to messages

You can reply to direct messages and broadcasts in the **Inbox**.

To reply, perform a long hold on a received direct message or broadcast until the context menu appears:

- **Reply** — Reply to a direct message with a direct message.
- **Broadcast reply** — Reply to a broadcast with a broadcast.
- **Reply / Broadcast reply (with Link ID)** — Reply to a direct message or broadcast that has a link ID by responding with a direct message or broadcast that contains the same link ID.

Onscreen keyboard

Use the onscreen keyboard to type your messages. Messages can contain a maximum of 57 characters.

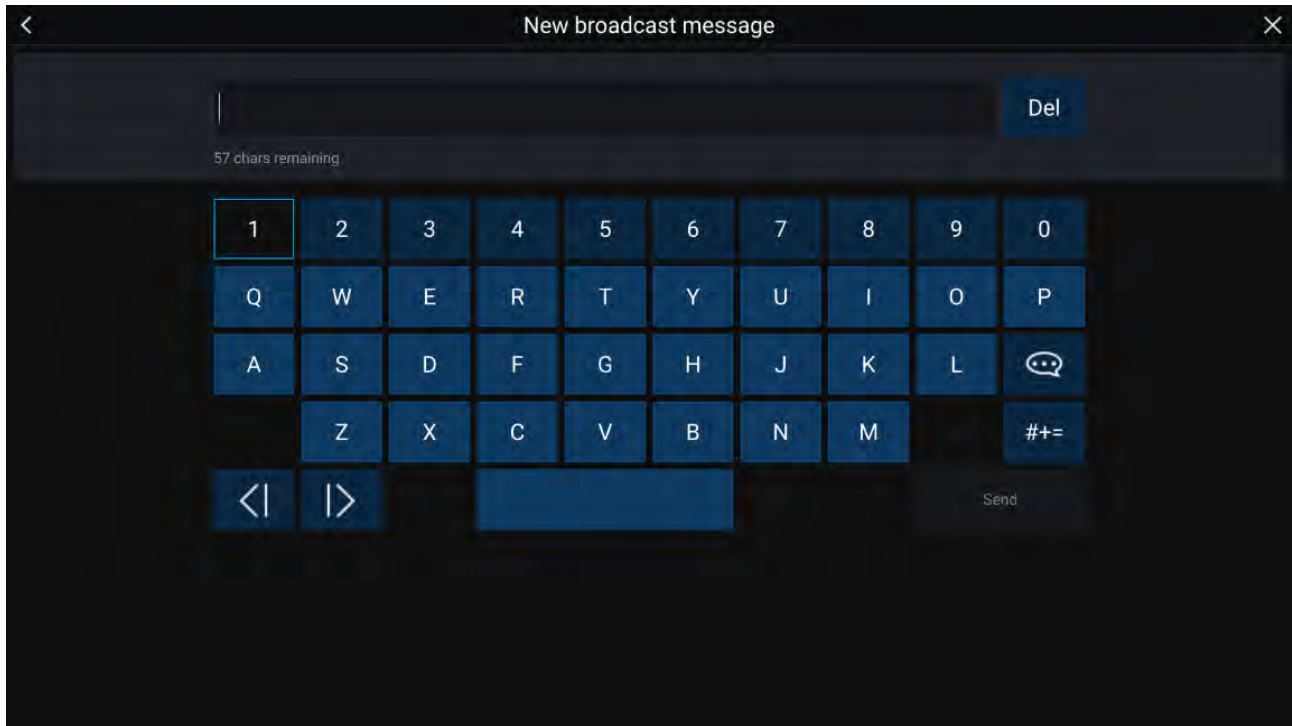

Selecting the **Template Text** icon will change the onscreen keyboard to a list of template messages that can be quickly added to the message when selected. Selecting **My Position** will enter your vessel's current coordinates into the message.





Note:

Coordinates entered into the message display degrees as **'DEG'**.

Message symbols

Symbols attached to messages in the **Inbox** indicate its type and status.

	Broadcast — A broadcast to all other responder vessels.
	Direct message — A direct message to a specific responder vessel.
	Sender — Indicates the sender (left of the arrow) and recipient (right of the arrow) of a direct message.

	Message sent — Direct message has been sent and acknowledged by the recipient's hardware.
	Message sending — Direct message is still waiting to be acknowledged as successfully received by the recipient's hardware. Note: A maximum number of 4 attempts will be made to send the message by the sender's hardware, with 150 seconds of separation between each attempt.
	Message failed to send — Direct message has failed to be acknowledged by the recipient's hardware. Note: The failed message will remain in the Inbox .
	Link ID — A link ID generated and used by responder vessels. Note: Replying to a direct link message or broadcast that has a link ID will send a reply that contains the same link ID.

5.10 Alarms

Alarms are used to alert you to a situation or hazard requiring your attention. Alarms are triggered by system functions and external devices connected to the MFD (Multifunction Displays). Alarms are displayed on all networked MFDs.

Alarms are color coded to signify their severity:

Dangerous alarms



Red — A Red notification is used to signify a dangerous alarm condition, immediate action is required due to a potential or immediate danger to life or vessel. Dangerous alarms are accompanied by an audible tone. The Dangerous alarm notification and audible tone will continue to be displayed until acknowledged or the conditions that triggered the alarm are no longer present. Acknowledged alarms may remain active whilst the alarm condition persists but will not trigger further onscreen or audible notifications.

Warning alarms



Orange — An Orange notification is used to signify a warning alarm condition. Warnings alarms are used to signify that there has been a change in situation that you need to be aware of. Warnings alarms are accompanied by an audible tone. The warning alarm notification and audible tone will continue to be displayed until acknowledged or the conditions that triggered the alarm are no longer present. Acknowledged alarms may remain active whilst the alarm condition persists but will not trigger further onscreen or audible notifications.

Notifications

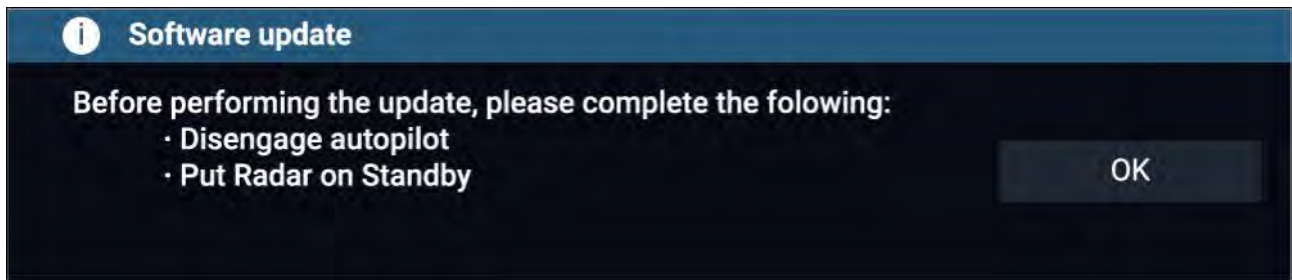

Blue — A Blue notification is used to signify information requiring user acknowledgement. Unless they require user interaction, information notifications may self dismiss after 3 seconds. Information notifications are not accompanied by an audible tone and are not displayed in the Active alarms or Alarm history lists.

Alarm manager

The Alarm manager is used to list current active alarms, enable and disable alarms, adjust alarm thresholds and view Alarm history.

Active alarms

The Alarm manager can be accessed by selecting **Alarms** from the Homescreen.

Example: Active alarms tab



The Active alarms tab lists all alarms that are currently active. Alarms will remain active until the conditions that triggered the alarm are no longer present, e.g.: a Shallow depth alarm will automatically dismiss when the depth becomes deeper.

Alarm history

Example: Alarm history tab



All Dangerous (Red) and Warning (Orange) alarms will appear in the Alarm history list. The history list will include an entry for the alarm being triggered (raised) and also for when the alarm is acknowledged (cleared). The Alarm field contains the name of the alarm and the events field contains details of the alarm condition and its time and date.

The Alarm history list can be cleared by selecting **Clear history**.

Active alarm indication

Your MFD can be configured to provide active alarm indication from the Homescreen and from MFD apps. When enabled the Homescreen **Alarms** icon and MFD app's Home icon will indicate that an alarm is currently active.

Active alarm indication can be enabled and disabled from the alarms settings tab: **Homescreen > Alarms > Settings > Home button active alarm indicator**.

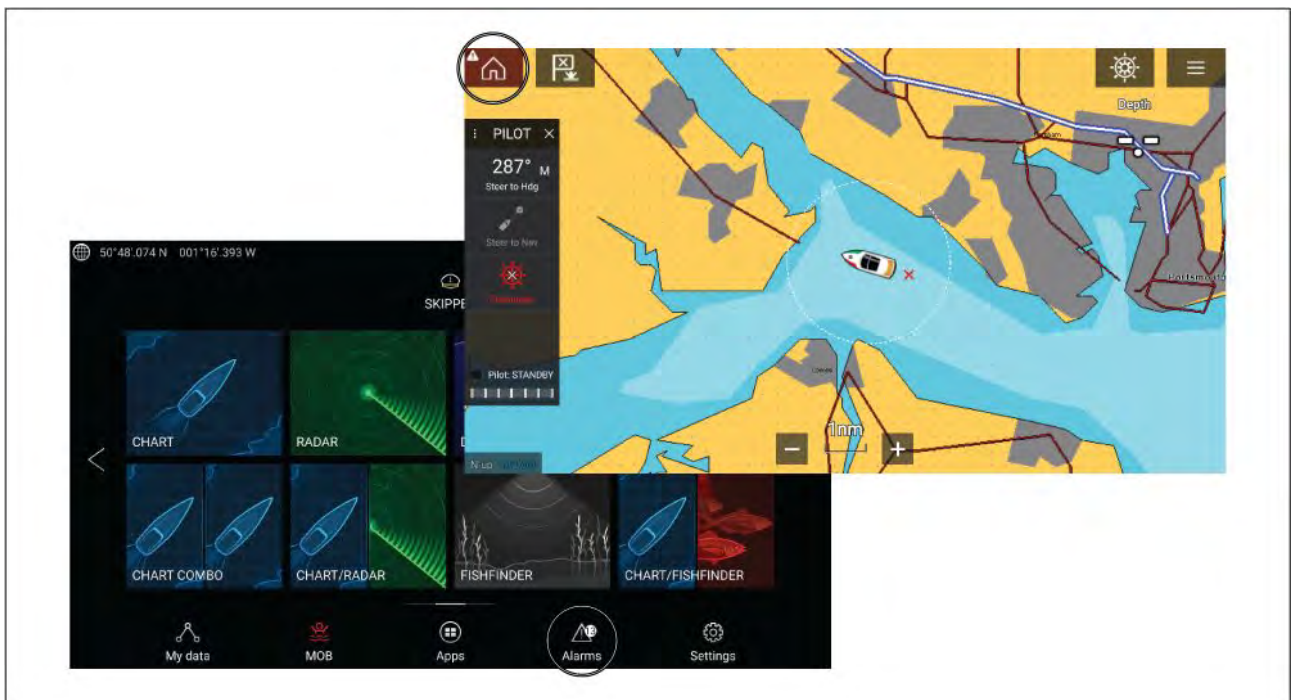

The Home icon will turn Red and have an exclamation mark placed inside it.

The Homescreen Alarms icon will display the number of active alarms.

Alarm settings

Depending on connected peripheral hardware the alarms listed below can be enabled and disabled and where applicable alarms thresholds can be set or changed.

Alarm	Description	Options
Dangerous Radar targets	<p>If enabled, an alarm is triggered when Radar targets become dangerous. Radar targets are deemed dangerous when they are within the specified:</p> <ul style="list-style-type: none"> • Safe distance — Closest Point of Approach (CPA), or • Time to reach safe distance — Time to Closest Point of Approach (TCPA) 	<ul style="list-style-type: none"> • On • Off
Lost Radar targets	<p>If enabled, an alarm is triggered when dangerous Radar targets become lost (i.e.: no Radar return from the target has been received for 20 seconds).</p>	<ul style="list-style-type: none"> • On • Off
Dangerous AIS targets	<p>If enabled, an alarm is triggered when AIS targets become dangerous. AIS targets are deemed dangerous when they are within the specified:</p> <ul style="list-style-type: none"> • Safe distance — Closest Point of Approach (CPA), or • Time to reach safe distance — Time to Closest Point of Approach (TCPA) 	<ul style="list-style-type: none"> • On • Off
Guard zone 1	<p>If enabled, an alarm is triggered when Radar returns are detected within the specified guard zone 1.</p>	<ul style="list-style-type: none"> • On • Off
Guard zone 2	<p>If enabled, an alarm is triggered when Radar returns are detected within the specified guard zone 2.</p>	<ul style="list-style-type: none"> • On • Off
Waypoint arrival	<p>If enabled, when you arrive at a waypoint, an alarm is triggered. This setting allows you to select one of three different types of radius, and then specify the radius size for the arrival alarm. When your vessel crosses this imaginary circle, the Waypoint Arrival alarm is triggered.</p>	<ul style="list-style-type: none"> • On • Off
	<p>Arrival radius — This value can be set when the MFD is NOT in pilot integration mode and the pilot is in Track mode.</p>	<p>Radius can be set from 20 m to 10 NM. (Dependent on units of measure you specify for Distance units in System Settings).</p>
	<p>Pilot track mode radius — This can be used when the MFD is integrated with a pilot and the pilot is in Track mode.</p>	<p>Radius can be set from 20 m to 10 NM. (Dependent on units of measure you specify for Distance units in System Settings).</p>

Alarm	Description	Options
	<p>Search route arrival radius — This can be used when the MFD is following a SAR route. Also helpful when race sailing and using Laylines or when fishing, as this alarm setting provides a much tighter default radius to ensure you don't get alerted too far away from the target waypoint.</p>	<p>Radius can be set from 3 m to 10 NM. (Dependent on units of measure you specify for Distance units in System Settings).</p>
Off track	<p>If enabled, during active navigation an alarm is triggered when your vessel steers off track by more than the specified Cross track error value.</p>	<ul style="list-style-type: none"> • On • Off <p>Cross-track error value</p>
Anchor drift	<p>If enabled, an Alarm is triggered when your vessel drifts from your anchor position by more than the specified Drift range.</p>	<ul style="list-style-type: none"> • On • Off <p>Drift range value</p>
Low fuel remaining	<p>If enabled, an alarm is triggered when the fuel remaining in your fuel tanks reaches the Fuel level specified. The Fuel manager must be enabled for alarms to be triggered.</p>	<ul style="list-style-type: none"> • On • Off <p>Fuel level value</p>
DSC alarms	<p>If enabled, an alarm is triggered when DSC distress calls are received. A connected VHF radio is required in order to trigger DSC distress call alarms via the MFD.</p>	<ul style="list-style-type: none"> • On • Off
AIS safety messages	<p>If enabled, an alarm is triggered when AIS safety messages are received. A connected AIS device is required in order to display AIS safety messages via the MFD.</p>	<ul style="list-style-type: none"> • On • Off
MOB data type	<p>Determines whether the MOB waypoint is fixed at the position the alarm was triggered, or advances its position based on tide and wind effects. Dead reckoning normally provides a more accurate course.</p>	<ul style="list-style-type: none"> • Dead reckoning • Position (fixed)
Fishing range	<p>If enabled, an alarm is triggered when your Depth reading reaches the depth specified in Shallow water arrival or Deep water arrival.</p>	<ul style="list-style-type: none"> • On • Off <p>Shallow water arrival value Deep water arrival value</p>
Water temperature alarm	<p>If enabled, an alarm is triggered when the water temperature reading reaches the temperature specified in Lower temp limit or Upper temp limit.</p>	<ul style="list-style-type: none"> • On • Off <p>Lower temp limit value Upper temp limit value</p>

Alarm	Description	Options
Digital switching alarms	When your system includes Digital switching a list of all configured Digital switching alarms will be displayed.	<ul style="list-style-type: none"> • On • Off
AX8 camera messages	If enabled, AX8 camera messages will be presented as alarms on your MFD. A connected AX8 camera is required in order to display camera messages via the MFD.	<ul style="list-style-type: none"> • On • Off
Engine alarms	If enabled, alarms will be triggered when engine warning alarms are received from connected, compatible engine management systems or interfaces.	<ul style="list-style-type: none"> • On • Off
Home button active alarm indicator	If enabled, when an alarm is active the onscreen Home icon is colored Red and contains a warning triangle.	<ul style="list-style-type: none"> • On • Off

External alarm speaker / buzzer

If your MFD has a built-in buzzer or is connected to a wired external buzzer then MFD alarms will trigger an audible tone. If you connect your MFD to a Bluetooth speaker then the alarm tone can also be heard from the speaker as well.

When connected to a Bluetooth speaker a separate volume control is available to control the volume of MFD Alarms sounded through the speaker. Please refer to the [Bluetooth speaker pairing](#) details.

Acknowledging alarms

Follow the steps below to acknowledge an active alarm.

With an alarms notification displayed onscreen:

1. Select **OK**.

The notification is dismissed and the audible tone is stopped.

An acknowledged alarm remains active until the conditions that triggered the alarm are no longer present.

Note:

If an alarm notification includes an **Edit** button, selecting it will display the relevant setting in the Alarms menu so that, if required, you can change the alarm threshold.

Digital switching alarms

When your MFD is connected to a Digital switching system, alarms specific to your installation can be enabled and disabled using the Alarm manager.

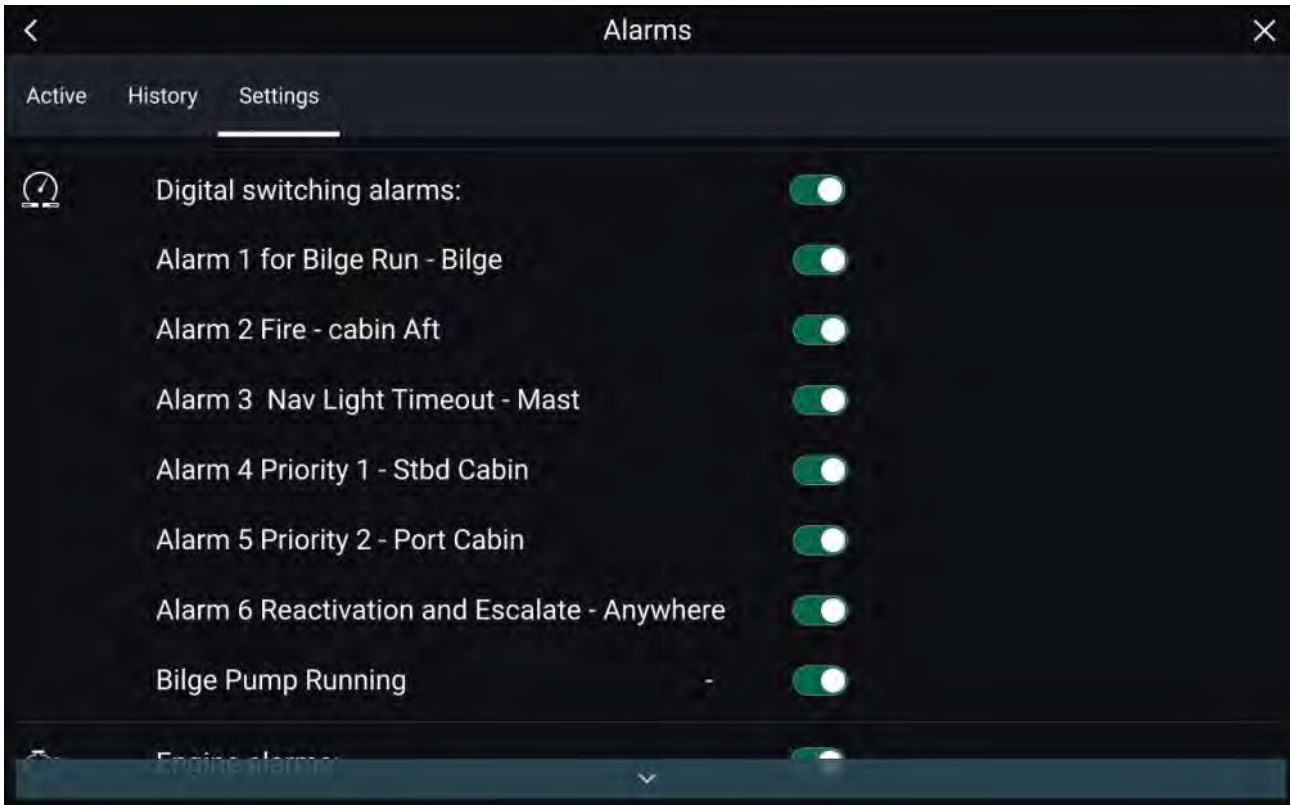

Example: Digital switching alarms



Each Digital switching system may be unique, with the alarms being defined when your system was configured.

5.11 Man Overboard (MOB)

If a person or object falls overboard, you can use the Man Overboard (MOB) feature to mark the position that your vessel was at when the MOB alarm was activated.

	The MOB feature can be activated by pressing and holding on the MOB icon on the Homescreen.
	The MOB waypoint icon displayed at the top of all apps.

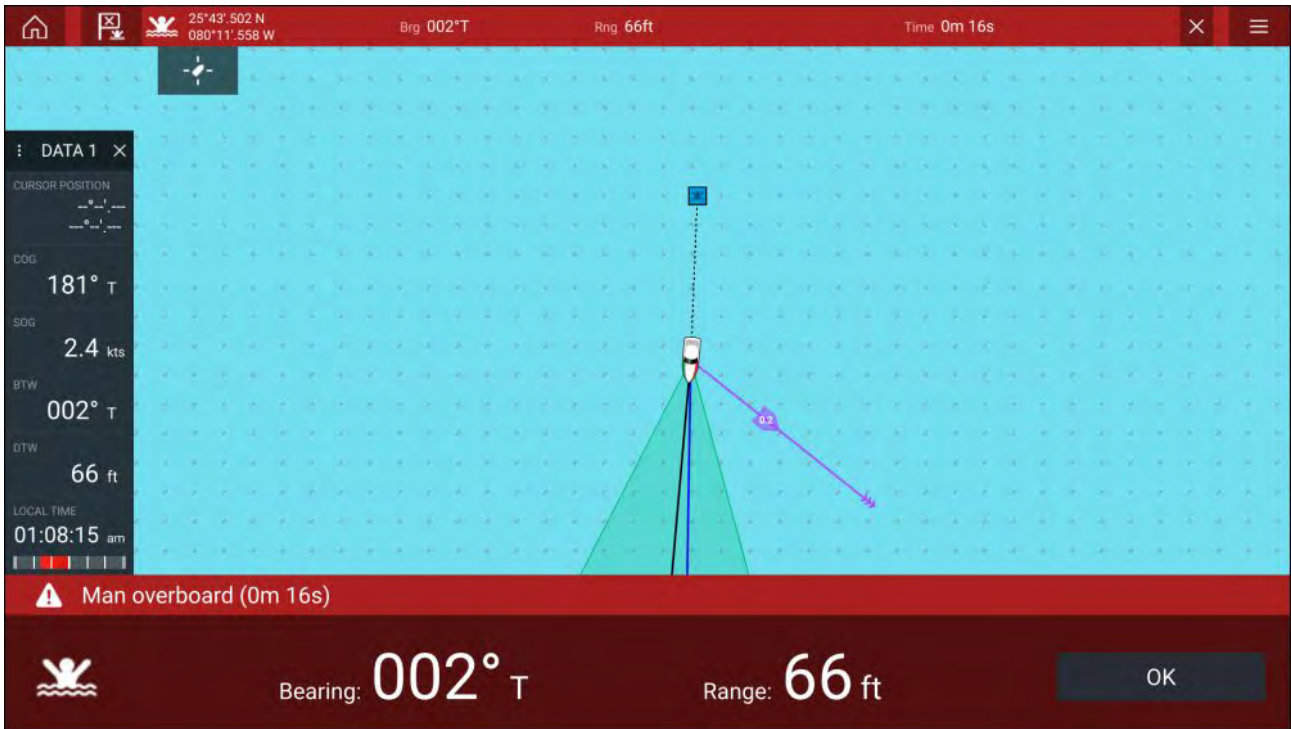

The MOB feature requires your vessel to have a valid position fix from a GNSS (GPS) receiver. Dead reckoning mode also requires Heading and Speed data.

When you activate the MOB alarm:

- an audible alarm is sounded which is repeated every 30 seconds until the alarm is cancelled.
- a MOB Databar providing Bearing and range from MOB, and elapsed time since MOB was initiated, is displayed along the top of the screen. The Databar persists across apps and the Homescreen, and remains until the MOB alarm is cancelled.
- a MOB warning is displayed in the bottom of the screen, which requires acknowledgement.
- the Chart app is placed in a special MOB mode to help you navigate back to the point your vessel was at when the MOB was initiated.

MOB mode

MOB can be set to Dead Reckoning or Position mode. Dead Reckoning mode will take into consideration the effects of wind and tides. This usually provides a more accurate course. Position mode does not take these factors into account. You can change the MOB mode at anytime from the Alarms menu: **Homescreen > Alarms > Settings > MOB data type:**

5.12 Settings

The Settings menu is accessible from the bottom of the Homescreen and contains important information and settings for your MFD.

The **Settings** menu is divided into different tabs, the settings available are:

Tab	Settings
Getting started	<ul style="list-style-type: none"> • View hardware and software information about your MFD. • View cartography details for inserted chart cards. • Update MFD software • View the LoU disclaimer (Getting started tab). • Change the user interface language. • View the Regulatory approvals.
Boat details	<ul style="list-style-type: none"> • Set boat icon and name. • Configure Sailing [Sailing vessel's only].

Tab	Settings
	<ul style="list-style-type: none"> • Configure Minimum safe depth, height and width. • Configure engines. • Configure batteries. • Configure fuel tanks.
Units	<ul style="list-style-type: none"> • Configure preferred units of measurement. • Configure Bearing mode. • Configure variation. • Configure GNSS (GPS) system datum. • Set time differentials.
This display	<ul style="list-style-type: none"> • Assign a Homescreen page or app to start on power up. • Select save location for screenshots. • ⁽¹⁾Configure User Programmable Button (UPB; Axiom Pro displays only). • Configure Shared brightness. • ⁽²⁾Change or reset Splashscreen graphic. • Pair / unpair connected RMK external keypads. • ⁽³⁾Enable / disable external alarm output. • ⁽²⁾Connect to a wireless display. • Wi-Fi Sharing, pair with a wireless Quantum Radar scanner, configure Wi-Fi settings and set mobile app access. • ⁽²⁾Connect to a Bluetooth device. • Perform a Settings or Factory reset.
Autopilot	<ul style="list-style-type: none"> • Enable / Disable Autopilot control. • Set autopilot response. • Access advanced autopilot settings.
Network	<ul style="list-style-type: none"> • View list of networked MFDs. • Assign the MFD Data master. • View software and network details for the MFD you are using. • Rename connected network devices. • Save or Erase diagnostics logs to external storage. • View and Save Diagnostic information about products connected to your MFD. • ⁽⁴⁾Set up NMEA 0183 options on an Axiom Pro. • Assign your preferred data sources (Data master only).
Responder (Requires AIS5000 and boat activity set to First Responder)	<ul style="list-style-type: none"> • Set responder vessel type and name. • Enter MMSI. • Set AIS mode. • Set passphrase. • Set number of days before passphrase auto-wipe.

Note:

- (1) Available on Axiom™ Pro MFDs.
- (2) Available on Axiom™, Axiom™ Pro and Axiom™ XL MFDs.
- (3) Available on Axiom™ XL and gS Series MFDs.
- (4) Available on Axiom™ Pro, Axiom™ XL, eS Series and gS Series MFDs.

Selecting display language

You can choose which language you want the display's user interface to use.

1. Select the **Language** button from the **Getting started** menu: **Homescreen > Settings > Getting started > Language**.
2. Select your desired language.

User Interface languages

The following languages are available:

Arabic (ar-AE)	Bulgarian (bg-BG)	Chinese (Simplified) (zh-CN)	Chinese (Traditional) (zh-TW)
Croatian (hr-HR)	Czech (cs-CZ)	Danish (da-DK)	Dutch (nl-NL)
English (en-GB)	English (en-US)	Estonian (et-EE)	Finnish (fi-FI)
French (fr-FR)	German (de-DE)	Greek (el-GR)	Hebrew (he-IL)
Hungarian (he-IL)	Icelandic (is-IS)	Indonesian (Bahasa) (id-ID)	Italian (it-IT)
Japanese (ja-JP)	Korean (ko-KR)	Latvian (lv-LV)	Lithuanian (lt-LT)
Malay (Bahasa) (ms-MY ZSM)	Norwegian (nb-NO)	Polish (pl-PL)	Portuguese (Brazilian) (pt-BR)
Russian (ru-RU)	Slovenian (sl-SI)	Spanish (es-ES)	Swedish (sv-SE)
Thai (th-TH)	Turkish (tr-TR)	Vietnamese (vi-VN)	

Boat details

To ensure correct operation and display of data you should set the Boat Details settings according to your requirements.

Boat details can be accessed from the **Settings** menu: **Homescreen > Settings > Boat Details**

Option	Description
Boat /Icon:	Selection determines the icon used to signify your vessel in the Chart app.
Boat Name:	Configures your system with your vessel's name.
[Sailing only] Sail performance:	Select Fixed Angles or Polar laylines.
[Sailing only] Boat type:	Select your vessel's Boat type to provide more accurate leeway calculations.
[Sailing only] [Fixed Angles only] Upwind angle:	Set the angle of upwind layline calculations.
[Sailing only] [Fixed Angles only] Downwind angle:	Set the angle of downwind layline calculations.
[Sailing only] [Polar only] Polar:	Select the Polar table that will define your layline calculation.

Option	Description
Min safe height:	Enter your vessel's maximum unladen height from the waterline. To ensure adequate clearance, it is recommended that you add a safety margin to this figure to allow for variation caused by vessel movements.
Min safe width:	Enter your vessel's maximum width at its widest point. To ensure adequate clearance on both sides, it is recommended that you add a safety margin for port and starboard to this figure to allow for variation caused by vessel movements.
Min safe depth:	Enter your vessel's maximum depth when fully laden. This is the depth from the waterline to the lowest point on the vessel's keel. To ensure adequate clearance, it is recommended that you add a safety margin to this figure to allow for variation caused by vessel movements.
Num of engines:	Select the number of engines on your vessel. When connected to a compatible system, your MFD can monitor engine data.
Identify engines:	Once you have selected the number of engines, select Identify engines and follow the onscreen instructions to configure your engines. May require an extra hardware interface to enable engine data to be displayed.
Engine manufacturer:	Select your engine's manufacturer.
[Num of engines 2 only] Configure Yamaha Quad display:	Select whether your MFD is displaying for a twin engine system, or for the port or starboard side of a quad engine system.
Num of Batteries:	Configures your system with the number of batteries on your vessel.
Tanks:	Calibrate your vessel's tanks.

Calibrating tanks

When displaying tank levels on your MFD it's important to ensure the levels are correctly calibrated. Failure to do so may result in inaccurate level readings.

Tanks can be calibrated and edited on the Boat details page: **Homescreen > Settings > Boat details**.

Tanks can be calibrated with the following Oceanic Systems tank senders:

- 3271 Volumetric Fuel Sender
- 3281 Water Level Senders
- 3125 Tank Sender Adapter
- 4291 Tank Level Adapter



Note:

- Ensure tanks are empty before calibration.
- Completing calibration will overwrite any existing calibration already recorded.

1. Press configure
2. Select the tank you want to calibrate; a dialog will be displayed
3. Set the tank's capacity
4. Select calibrate and choose the desired method for tank calibration:

- i. Run wizard
- ii. Import calibration

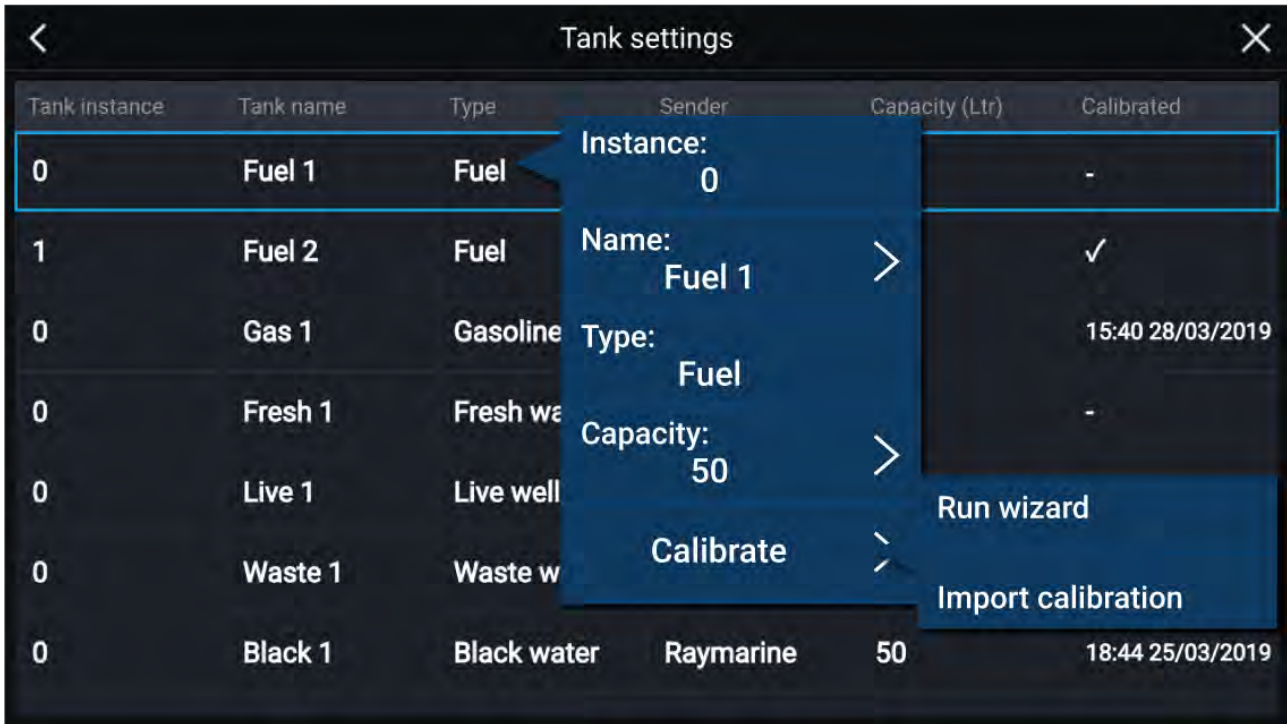

Run wizard calibration

You can calibrate your tank by setting a series of **calibration points** and filling your tank in intervals. The shape of your tank determines how many calibration points you should enter for calibration. 2 calibration points are required as a minimum, but up to 101 points can be entered. Generally, the more calibration points entered the more precise tank readings will be.

Additional calibration points are used to account for changes in tank volume at different parts of an irregularly shaped tank. Depending on the size and shape of your tank it is recommended that you enter calibration points to mark each change in the shape of the fuel tank; for example, straight corners require an additional point, and slopes require 2 points.

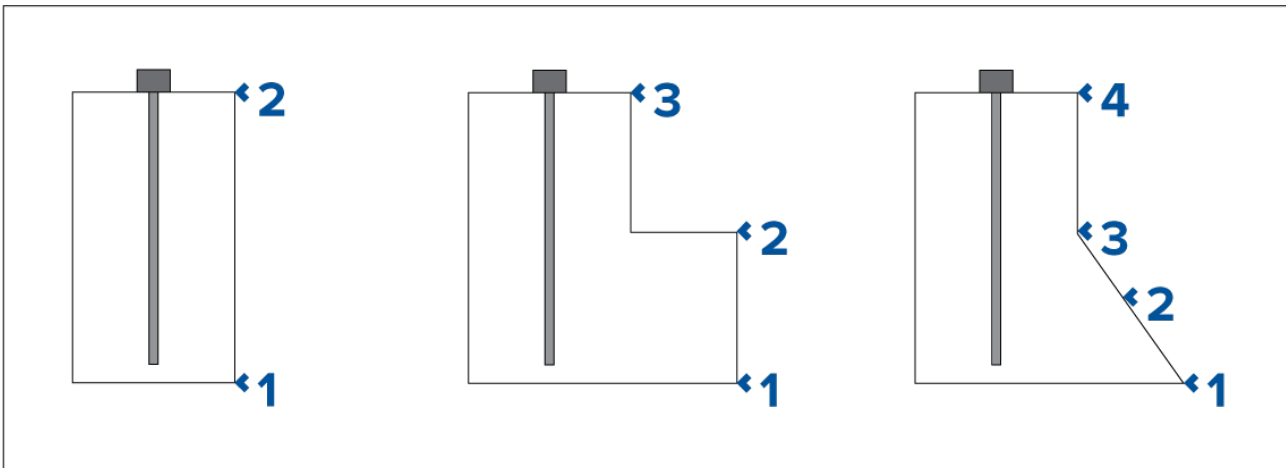

The illustration above shows the minimum number of calibration points recommended for some typical tank shapes:

1. The tank shown on the left is rectangular and symmetrical; it only requires 2 calibration points to define the bottom and top of the tank.
2. The tank shown in the center has a greater volume at the bottom; 3 points are required to define the bottom, top and corner of the fuel tank.
3. The tank shown on the right has a greater volume at the bottom and is sloped. 4 points are required to define the bottom of the tank, the top, and a further 2 points to define the slope.

Wizard Calibration

1. Select the number of calibration points (minimum of 2) and press **next**.

2. Fill the tank to the units displayed on screen and press **Ok**.
3. To complete the calibration process, repeat step 2 until the tank has been filled.

Import calibration

You can calibrate your tanks by importing CSV files that contain specific tank calibration data. These files are typically supplied by tank manufacturers or dealers.

Note: CSV files used for import calibration must start with: '0,0' and end in: '100,100'

To **Import calibration** via CSV file:

1. Select the appropriate CSV file from the file explorer.
2. Press **Yes**.

Units of measure

You can select your preferred units for data readings from the **Units** tab of the **Settings** menu: **Homescreen > Settings > Units**.

Measurement	Units
Distance units	<ul style="list-style-type: none"> • Nautical Miles • NM & m • Statute Miles • Kilometers
Speed units	<ul style="list-style-type: none"> • Kts • MPH • KPH
Depth units	<ul style="list-style-type: none"> • Meters • Feet • Fathoms
Temperature units	<ul style="list-style-type: none"> • Celsius • Fahrenheit
Date format	<ul style="list-style-type: none"> • MM : DD : YYYY • DD : MM : YYYY • MM : DD : YY • DD : MM : YY
Volume units	<ul style="list-style-type: none"> • US Gallons • Imperial Gallons • Liters
Economy units	<ul style="list-style-type: none"> • Distance per Volume • Volume per Distance • Liters per 100 km
Wind speed units	<ul style="list-style-type: none"> • Knots • Meters per Second
Pressure units	<ul style="list-style-type: none"> • Bar • PSI • Kilopascals
Time format	<ul style="list-style-type: none"> • 12hr • 24hr

Data master

Systems containing more than one MFD must have a designated Data master MFD. The Data master is the primary MFD in the network, and should be the MFD that is physically connected to the SeaTalkng® / NMEA 2000 CAN bus network, and any other devices and sources of data in your system. The Data master bridges the data over the SeaTalkhs™ network to any compatible networked 'repeater' MFDs.

Information shared by the Data master includes:

- Cartography
- Waypoints, Routes and Tracks
- Radar
- Sonar
- Data received from the autopilot, GNSS (GPS) receiver, instruments, transducers, the engine and any other compatible external sources.

Note: Your system may be wired for redundancy with data connections made to repeat displays. However these connections will only become active in the event of a fault and / or reassignment of the data master.

Switching Data Master

You can switch the MFD you want to be the Data master at any time.



From the Network tab: **Homescreen > Settings > Network:**

1. From the list, select the MFD you want to designate as the new Data master.
2. Select **Assign as Data Master** from the pop-over options.

Shared Brightness

Shared brightness enables simultaneous brightness adjustment of all displays that are part of the same group.

The following products are compatible with shared brightness:

- LightHouse™ 3 MFDs using software version 3.4 or greater.
- LightHouse™ or LightHouse™ 2 powered MFDs.
- SeaTalkng® Instrument displays and Pilot controllers.
- SeaTalkng® VHF DSC Radios.
- RMK-9 and RMK-10 remote keypads.

Any adjustments to the shared brightness level will be applied to all displays assigned to the same group.

<p>LightHouse™ / LightHouse™ 2 MFD</p> 	<p>Instrument display / Pilot controller</p> 
<p>VHF DSC Radio</p> 	<p>LightHouse™ 3 V3.4 or greater</p> 

Multiple brightness groups can be configured. For example, these groups could be used to reflect the physical location of displays on your vessel e.g.: helm and flybridge.

Shared brightness requires:

- all units to be compatible with the shared brightness function (see list of compatible units above).
- the **Shared brightness** setting set to On for all displays in the brightness group.
- units to be assigned to network groups.
- all the displays in each group to be synchronized.

Setting up shared brightness

Before setting up Shared brightness on your MFD, ensure that all displays that you want to use Shared brightness are switched on and set to the same Display group as your MFD.

1. Select **This display** from the **Settings** menu: **Homescreen > Settings > This display**.
2. Select **Display group**.
A list of available display groups is displayed.
3. Select the Display group that you want the MFD to be part of (All displays that you want to share brightness with must be set to the same group).
4. Enable **Shared brightness** using the Toggle switch.
5. Select **Sync**.

'Shared brightness active' is displayed when complete.

Customizing the splashscreen

The standard AXIOM splashscreen, displayed on start up, can be customized on Axiom™, Axiom™ Pro, and Axiom™ XL displays.

Custom Image requirements:

- The customized image must be in .png, .bmp or .jpg format.
- Custom images cannot exceed the maximum resolution supported by your MFD.
- For optimum image quality, the resolution of the splashscreen image should match the resolution of your MFD. Refer to the following table: [Axiom screen resolutions](#).

Note:

- Splashscreen settings are unique to each MFD and are not shared across the network with other MFDs.
- Custom splashscreens are not available on eS Series and gS Series MFDs that have been upgraded to run LightHouse 3 software.

1. Save your custom image to a MicroSD card and insert the card into a card reader slot on your MFD or connected card reader.
2. Select **This display** from the **Settings** menu: **Homescreen > Settings > This display**.
3. Select the image name next to **Splashscreen**:
The file browser is displayed.
4. Browse to your custom image and select it.
5. Select **Yes**.
The image is imported to your MFD's internal storage.

The next time your MFD powers up, your custom image will be displayed.

Axiom screen resolutions

The screen resolutions for Axiom™, Axiom™ Pro, and Axiom™ XL displays are shown below.

MFD variant	Screen resolution (W x H)
Axiom™ 7	800 x 480
Axiom™ 9	800 x 480
Axiom™ 12	1280 x 800
Axiom™ Pro 9	1280 x 720
Axiom™ Pro 12	1280 x 800
Axiom™ Pro 16	1920 x 1080
Axiom™ XL 16	1920 x 1080
Axiom™ XL 19	1920 x 1080
Axiom™ XL 22	1920 x 1080
Axiom™ XL 24	1920 x 1200

Resetting the splashscreen graphic

1. Select **This display** from the **Settings** menu: **Homescreen > Settings > This display**.
2. Select the **Reset** from the Splashscreen section.
3. Select **Yes**.

The next time your MFD starts up the standard AXIOM splashscreen will be displayed.

NMEA 0183 settings

NMEA 0183 devices can be connected to Axiom™ Pro, Axiom™ XL, eS Series, and gS Series MFDs using the NMEA 0183 wires on the supplied Power/Video/NMEA 0183 cable.

2 NMEA 0183 ports are available:

- **Port 1:** Input and output, 4,800 or 38,400 baud rate.
- **Port 2:** Input only, 4,800 or 38,400 baud rate.

The baud rate for each input port must be specified in the **NMEA set-up** menu (**Homescreen > Settings > Network > NMEA set-up**).

Note:

- For Port 1, both the input and output communicate at the same baud rate. For example, if you have one NMEA 0183 device connected to Port 1 INPUT, and another NMEA 0183 device connected to Port 1 OUTPUT, both NMEA devices must use the same baud rate.

NMEA 0183 settings

The following options are available from the **NMEA Set-up** menu.

Menu item	Description	Options
NMEA Port 1	Baud rate selection.	<ul style="list-style-type: none"> 4,800 38,400
NMEA input port 2	Baud rate selection.	<ul style="list-style-type: none"> 4,800 38,400
Bridge heading	Bridge heading data from NMEA 0183 to NMEA 2000 / SeaTalkng®	<ul style="list-style-type: none"> Yes No
Transmission mode	<p>Switches between Single-ended and Differential transmission modes. The Differential transmission mode supports higher speeds, longer cable runs, and better data integrity. Differential mode works when connected to opto-isolated inputs, as specified by the NMEA 0183 standard. The Single-ended mode is required when sending a signal to a single-ended receiver device, such as a PC for example. Refer to the <i>NMEA 0400 Installation Standard</i> for wiring guidelines for the different transmission modes.</p> <div style="border: 1px solid black; padding: 5px; margin-top: 10px;"> <p>Note: Only available on Axiom™ Pro and Axiom™ XL displays.</p> </div>	<ul style="list-style-type: none"> Single-ended Differential
Individual outputs	List of NMEA 0183 sentences for which the output can be disabled.	<ul style="list-style-type: none"> Enabled Disabled

Responder setup

The Responder settings tab allows you to setup secure AIS transmission between Blue Force vessels.

Note:

- Blue Force features require an AIS5000 connected to your MFD network.
- Requires LightHouse software version 3.10 or later.
- Requires that MFD boating activity is set to **First Responder** during first time setup or a factory reset. **This profile is only available if an AIS5000 unit is connected to the MFD, prior to power up.**
- For more information on Blue Force, refer to: [p.139 – Blue Force SITREP](#)

Setting	Description
Responder vessel type	Select your responder vessel type from a list.
Boat name	Enter your vessel name (this option is also available in Boat Details)

Setting	Description
MMSI	<p>Set your vessel's MMSI number.</p> <div style="border: 1px solid black; padding: 5px;"> <p>Important:</p> <ul style="list-style-type: none"> • In the United States of America (USA), the MMSI and Static Data must be entered only by a Raymarine® dealer or other appropriately qualified installer of marine communications equipment for marine vessels. In the USA, the user is NOT authorized to do this. • In Europe and other parts of the world outside of the United States of America, the MMSI can be set up by the user. • For further details, refer to the relevant Telecommunications Regulatory Body for your region. </div>
AIS mode	<ul style="list-style-type: none"> • Normal — In this mode your AIS hardware will receive and transmit standard ITU position messages and secure ASMs (Application Specific Messages). • Receive only — In this mode your AIS hardware will receive standard ITU position messages and secure ASMs it will not transmit any messages (maintaining radio silence). • Restricted — In this mode your AIS hardware will <i>receive</i> standard ITU position messages and secure ASMs, but will only <i>transmit</i> secure ASMs.
Passphrase	Enter the designated passphrase your team / organization is using to transmit and receive secure AIS messages.
Clear passphrase	Deletes the entered passphrase.
Passphrase auto-wipe	Passphrase expiry. Set the number of days before the passphrase is automatically deleted (the passphrase will be wiped at 00:00 UTC).

5.13 Connecting to a wireless display

Axiom™, Axiom™ Pro, and Axiom™ XL MFDs can be connected to a wireless display using an external dongle or a display that has built-in support. When connected the MFD's screen is mirrored on the wireless display.

1. Follow the instructions provided with your wireless display / dongle to set up that specific device.
2. On the MFD, select the display icon found under **Wireless display:** on the **This Display** tab of the **Settings** menu: (**Homescreen > This Display > Wireless Display:**).

Your MFD will search for available wireless displays.



3. Select the display you want to use.
4. If your MFD has Wi-Fi Sharing enabled then a PIN number is displayed on the wireless display, input this pin number when requested by your MFD.
5. You may also be requested to allow the MFD to connect automatically in future, select **Yes** or **No** as appropriate on your wireless display.
Your MFD screen will now be displayed on the select device.
6. To allow the wireless display to connect each time your MFD is powered on, enable **Connect on power up** from the pop-over options.



Note:

1. Don't forget to check your wireless display for any required confirmations / acknowledgements during the connection process.
2. Some non Miracast-certified devices may not be able to connect with Wi-Fi Sharing enabled, in this case disable Wi-Fi Sharing and try again.
3. If you experience connection issues, try disabling and enabling the wireless display feature on your display and MFD, or power cycle both devices.
4. Once connected / paired to a wireless display do not change your MFD's Wi-Fi Passphrase, as on certain devices a factory reset maybe required to re-establish a connection.

Disconnecting a wireless display

With a wireless display connection active:

1. Select **Disconnect** from the **This Display** tab: (**Homescreen > Settings > This Display > Wireless Display: > Disconnect**).

Unpairing a wireless display

With the wireless display connection active:

1. Select the connected display from the Wireless display menu: (**Homescreen > Settings > This Display > Wireless Display**).
2. Select the connected display from the list of available displays.
3. Select **Unpair** from the pop-over menu.

Chapter 6: Autopilot control

Chapter contents

- [6.1 Autopilot control on page 88](#)
- [6.2 Pilot sidebar on page 89](#)
- [6.3 Pilot pop-up on page 91](#)
- [6.4 Autopilot Control — Advanced settings on page 91](#)

6.1 Autopilot control

Your MFD can be integrated with an Evolution autopilot system and act as the autopilot's controller. Please refer to the documentation supplied with your autopilot for details on installing and connecting your autopilot to your MFD.

Autopilot control from your MFD can be enabled and disabled from the **Autopilot** tab in the **Settings** menu: **Homescreen > Settings > Autopilot > Pilot control**.

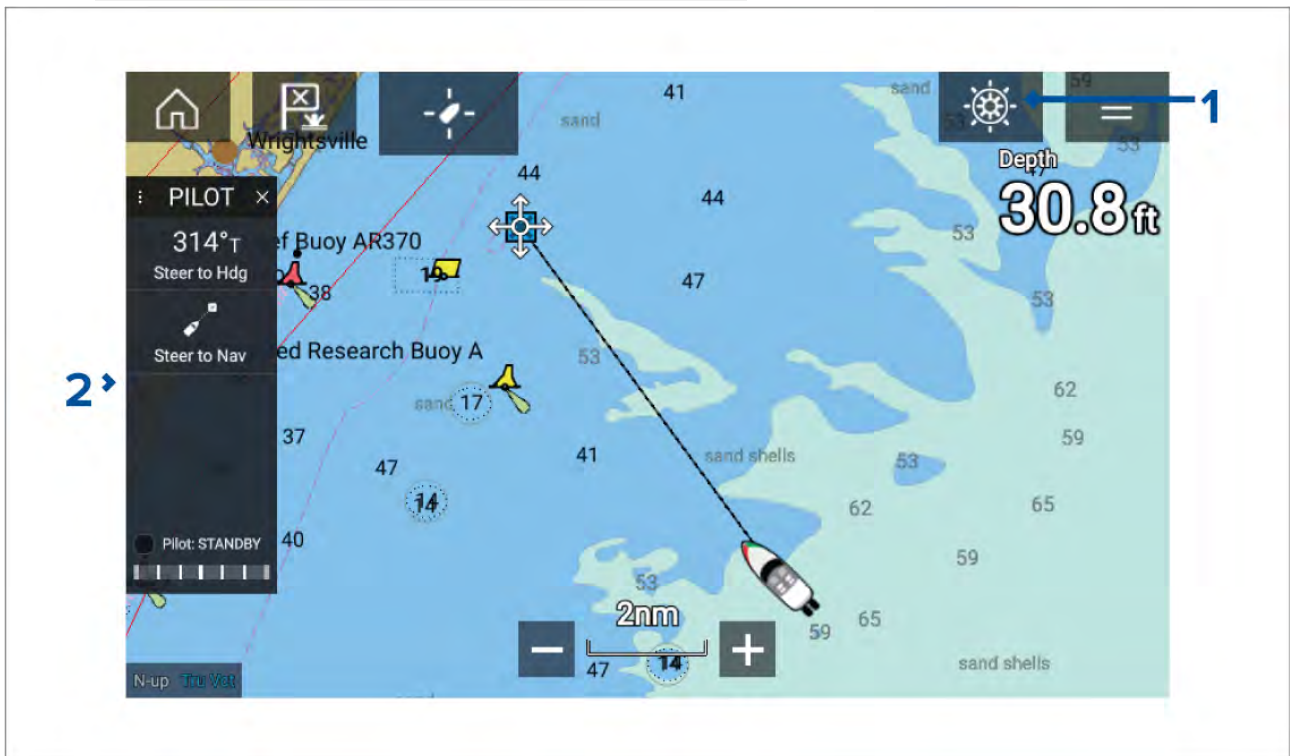

1. **Pilot icon** — With **Autopilot control** enabled, the Pilot icon is displayed onscreen; selecting the icon displays the Pilot sidebar. When the Autopilot is engaged the Pilot icon is replaced with the Disengage pilot icon.
2. **Pilot sidebar** — The Pilot sidebar provides controls and information relating to your autopilot system. With the Autopilot engaged the Pilot sidebar's content is expanded to provide further controls and information. The Pilot sidebar can be hidden by swiping the sidebar to the left. The sidebar can be displayed again by swiping from the left of the screen towards the center of the screen.

Engaging the autopilot — Locked heading

With Autopilot control enabled:

1. For Wheel and Tiller pilots, engage the mechanical drive by either engaging the wheel drive's clutch or attaching the pushrod onto the tiller pin.
2. Select the **Autopilot icon**.
The Pilot sidebar is displayed.
3. Select **Steer to Hdg**.
4. Select **Engage pilot**.

Engaging the autopilot — Navigation

With Autopilot control enabled:

1. For Wheel and Tiller pilots, engage the mechanical drive by either engaging the wheel drive's clutch or attaching the pushrod onto the tiller pin.
2. Initiate a Goto or Follow from the chart app.
3. Select the **Autopilot icon**.
The Pilot sidebar is displayed.
4. Select **Steer to Nav**.
5. Select either **Engage pilot** or if a cross track error exists then select **ALONG route leg** or **DIRECT from here**.

Selecting **ALONG route leg** will steer along the original track.

Selecting **DIRECT from here** will plot a new track from your current position to the destination.

Engaging and disengaging the autopilot - physical buttons

The process for engaging your autopilot using the physical buttons available on a RMK remote keypad or an Axiom Pro is shown below.

1. Press and hold the **Pilot** button to engage the autopilot in Locked heading mode.
2. Press the **Pilot** button again to disengage the autopilot.

Disengaging the autopilot

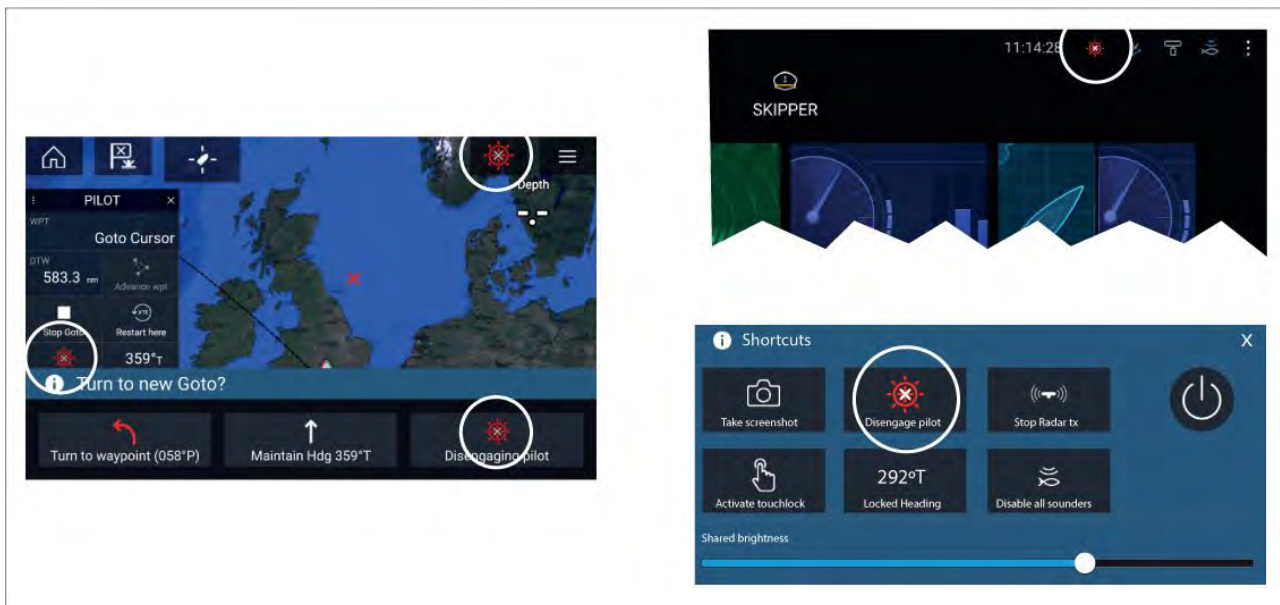

You can disengage your autopilot at any time by selecting the **Disengage pilot icon**.

The **Disengage pilot icon** is available in all apps. It is also available on the Pilot sidebar, in Pilot pop up messages, on the Homescreen and on the Shortcuts page.

6.2 Pilot sidebar

Depending on the state of your autopilot the following information and controls are available on the Pilot sidebar.

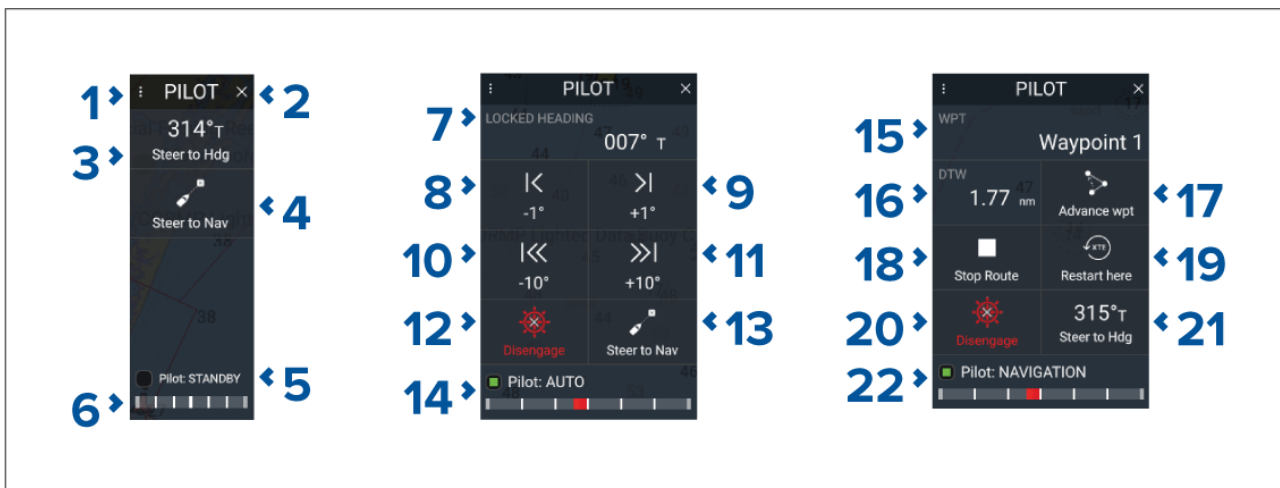

Note: The Pilot sidebar is controlled using the Touchscreen.

Pilot sidebar — Standby

1	Sidebar selection Enables you to switch between Pilot and Data sidebars.
2	Close Closes the Pilot sidebar.
3	Steer to Hdg Enables you to engage the autopilot in locked heading (Auto) mode.
4	Steer to Nav Enables you to engage the autopilot in Navigation (Track) mode.
5	Pilot status Provides the status of the autopilot.
6	Rudder bar Provides visual indication of rudder position.
7	Heading Displays your autopilot's current locked heading. Selecting displays the Locked Heading adjustment pop-over.
8	-1° Selecting will adjust your locked heading by minus 1 degree.
9	+1° Selecting will adjust your locked heading by plus 1 degree.
10	-10° Selecting will adjust your locked heading by minus 10 degrees.
11	+10° Selecting will adjust your locked heading by plus 10 degrees.
12	Disengage Selecting will disengage your autopilot.
13	Steer to Nav Selecting will engage your autopilot in Navigation mode.
14	Pilot state Displays the current state / mode of your autopilot.
15	Destination Displays your current destination.
16	User customizable data Displays user customizable data. Select to customize data.
17	Advance wpt Selecting will advance your destination to the next waypoint in the current route.
18	Stop Route / Stop Goto Selecting will stop current navigation.
19	Restart here Selecting will restart the cross track error (XTE) at your current location.
20	Disengage Selecting will disengage your autopilot.
21	Steer to Hdg Selecting will switch your autopilot to Locked heading mode.
22	Pilot state Displays the current state / mode of your autopilot.

6.3 Pilot pop-up

During active navigation, when you reach your current destination the Pilot pop-up is displayed.

Goto

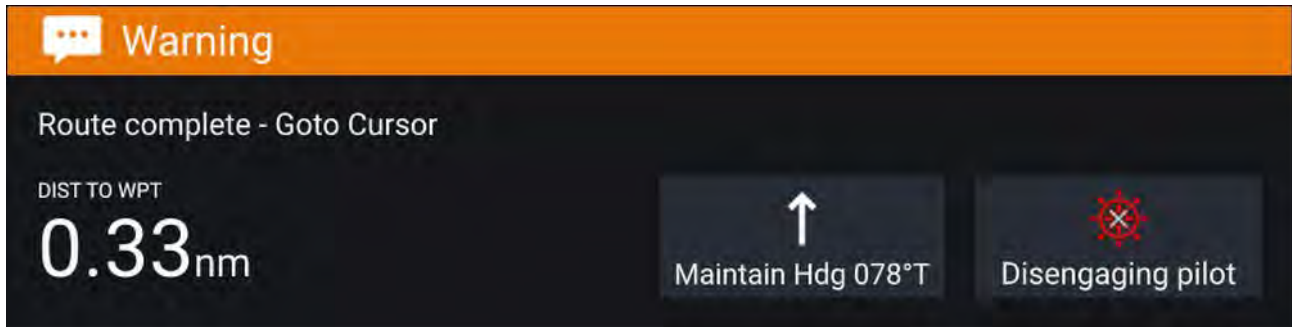

When performing a Goto the Pilot pop-up provides options to disengage the autopilot or to maintain the current course in Locked heading mode.

Follow

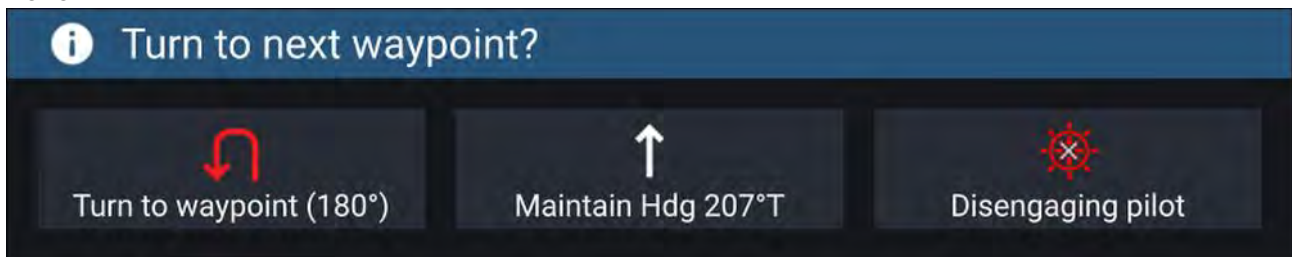

When following a Route the Pilot pop-up provides options to make the required turn to the next waypoint, disengage the autopilot or to maintain the current course in Locked heading mode.

6.4 Autopilot Control — Advanced settings

Menu item	Description	Options
Vessel hull type	Selecting the hull type that is the closest match for your vessel provides optimum steering performance.	<ul style="list-style-type: none"> Sail Sail (slow turn) Sail Catamaran Power Power (slow turn) Power (fast turn)
Drive type	Selecting the drive type that matches your vessel's drive will provide optimum drive performance.	List of drives compatible with your ACU.
Compass offset	Adjust the Compass offset so that your autopilot's heading matches the ship's compass. The display of autopilot heading data requires a second networked MFD or pilot controller. Compass offset will be adjusted automatically during the Align compass to GPS procedure .	<ul style="list-style-type: none"> -10° to +10° 0° (default)
Speed input ⁽¹⁾	Selects the source for speed data.	<ul style="list-style-type: none"> Auto (default) Water speed (STW) SOG Default cruise speed
Cruise speed ⁽¹⁾	Set the Cruise speed value to your vessel's typical cruising speed.	<ul style="list-style-type: none"> 4.0kts to 60.0kts

Menu item	Description	Options
Calibration lock	The calibration lock is used to lock out specific calibration settings which if changed may require recommissioning of the autopilot system. If your system has been dealer installed then the lock may be turned on.	<ul style="list-style-type: none"> • On • Off
Dockside wizard	Dockside calibration must be carried out before using your autopilot for the first time. The Dockside wizard guides you through the dockside calibration process. The steps included in the dockside wizard are dependent on whether you have a rudder reference transducer fitted to your vessel.	<ul style="list-style-type: none"> • Drive type • Rudder limit • Align rudder • Hard over time • Rudder drive check
Restart compass	Select to restart the compass linearization procedure.	<ul style="list-style-type: none"> • Start • Cancel
Compass lock	Locks the compass linearization so that further automatic linearization is not performed.	<ul style="list-style-type: none"> • On • Off
Align compass to GPS ⁽¹⁾	Follow the onscreen instructions to align your compass with your GPS heading.	
Pilot factory reset	Resets your autopilot's settings to factory default values.	<ul style="list-style-type: none"> • Yes • No
CCU debug level ⁽¹⁾	Sets a debug value for troubleshooting purposes. The debug level should only be set when requested by Technical Support as part of a troubleshooting process.	<ul style="list-style-type: none"> • 0 to 63
ACU debug level ⁽¹⁾	Sets a debug value for troubleshooting purposes. The debug level should only be set when requested by Technical Support as part of a troubleshooting process.	<ul style="list-style-type: none"> • 0 to 63
Rudder damping ⁽¹⁾	Rudder damping is used to prevent the autopilot from "hunting" maneuvers. Always use the lowest acceptable value.	<ul style="list-style-type: none"> • 1 to 9 • 3 (default)
Auto turn angle ⁽¹⁾	Determines the amount of course change when performing an auto turn.	<ul style="list-style-type: none"> • 10° to 125° • 90° (default)
Power steering ⁽³⁾	Determines the behavior of the Rotary or Joystick.	<ul style="list-style-type: none"> • Off • Proportional • Bang Bang
Reverse rudder ref ⁽³⁾	Inverts the rudder reference display graphic.	<ul style="list-style-type: none"> • On • Off
Motor phasing ⁽¹⁾	Switches the polarity of your drive motor. Use if your drive polarity is inverted.	<ul style="list-style-type: none"> • A • B
Rudder offset ⁽³⁾	Adjust to specify the rudder offset from amidships.	<ul style="list-style-type: none"> • -10° to +10° • 30° (default)
Rudder limit	Specifies how far the rudder can move before hitting its end stops. The value should be set to approximately 5° less than your maximum rudder angle.	<ul style="list-style-type: none"> • 10° to 50° • 30° (default)

Menu item	Description	Options
Hard over time	Specifies the time it takes for the rudder to move from hard port to hard starboard or vice versa. The default value is determined by your Drive type selection.	<ul style="list-style-type: none"> • 1 to 100.0 seconds
Gybe inhibit ⁽²⁾	When set to Prevent Gybe the autopilot will prevent you from performing an Auto tack away from the wind.	<ul style="list-style-type: none"> • Allow Gybe • Prevent Gybe
Wind vane type ⁽²⁾	Selects whether wind data is True or Apparent.	<ul style="list-style-type: none"> • Apparent • True
Wind shift alarm ⁽²⁾	Enables and disables the Wind shift alarm.	<ul style="list-style-type: none"> • On • Off

Note:

(1) Option not available when **Calibration lock** is **On**.

(2) Only available when Vessel hull type is set to a Sailing vessel.

(3) Only available when a rudder reference transducer is connected.

Chapter 7: Waypoints, Routes and Tracks

Chapter contents

- 7.1 Waypoints on page 96
- 7.2 Routes on page 98
- 7.3 Tracks on page 101

7.1 Waypoints

Waypoints are used to mark specific locations or points of interest. Waypoints can be used in the Chart, Radar and Fishfinder apps. Your MFD can store up to 10,000 waypoints which can be sorted into up to 200 waypoint groups.

In the Chart app you can navigate to a waypoint by selecting **Goto** from the Waypoint context menu.

Placing a waypoint

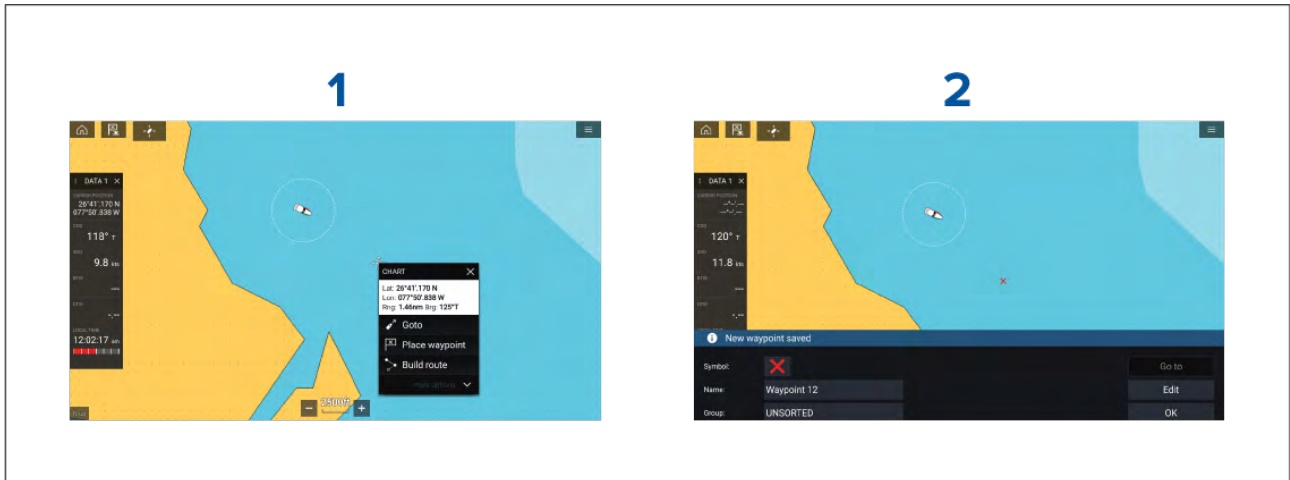

1. Select and hold on the desired location and select **Place waypoint** from the context menu..
2. Select **Edit** to edit the waypoint details, **Goto** to navigate to the Waypoint, or **OK** to return to normal operation.

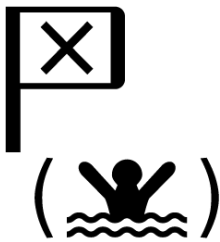

To place a waypoint at your vessel's current location press the Waypoint/MOB icon or physical button.

Placing a waypoint at a specified lat/long

You can place a waypoint at a specified latitude and longitude.

1. Select **New waypoint at lat/long** from the New page in the Chart app menu: **Menu > New > New waypoint at lat/long**
2. Enter the latitude and longitude for the waypoint.
3. Select **Save**.

Waypoint management

Waypoints are managed using the Waypoint list.

The Waypoint list can be accessed from the Homescreen and from the Chart app: **Homescreen > My data > Waypoints**, or **Chart app > Menu > Waypoints, routes, tracks > Waypoints**.

Waypoint list

The Waypoint list is sorted into groups. Selecting a group displays a list of all the waypoints included in that group. Selecting a waypoint displays the customizable details for that waypoint.



From the Waypoint list you can **Search** for a waypoint, Create a **New group**, Create a **New Waypoint** or **Delete** a waypoint group.

Selecting a Waypoint group from the list displays a list of all waypoints in that group.

Group lists

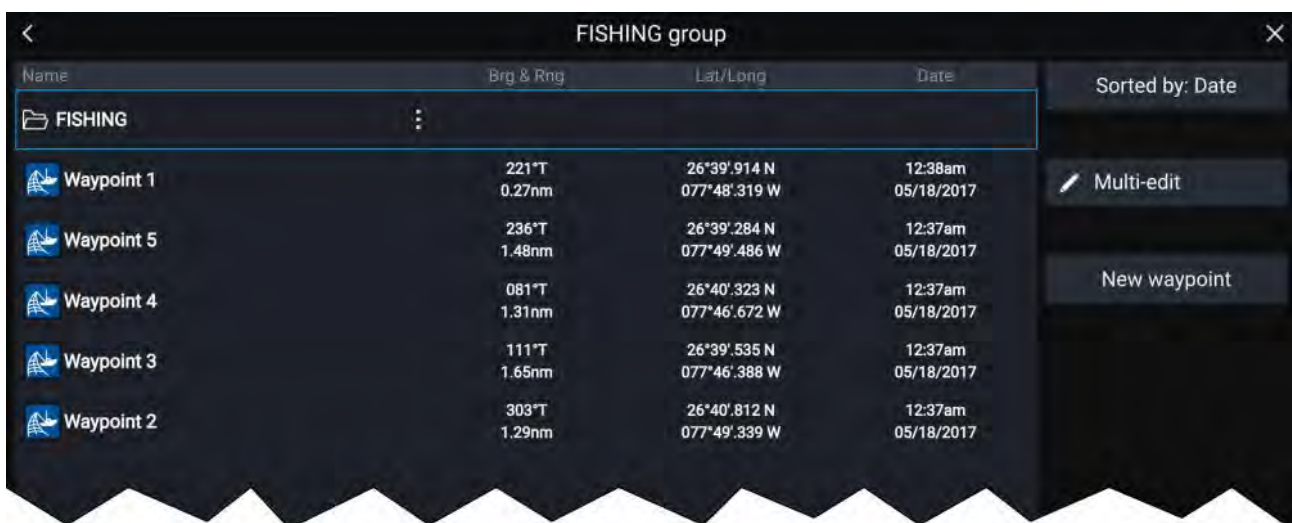

If the Waypoint list is accessed from the Chart app menu, the selected group or waypoint is displayed in a Chart pane on the right of the screen.

You can **Rename**, **Delete** or **Hide/Show** the group by selecting the Group name at the top of the list.

From the group list you can change the list sort order, Hide/Show the Waypoint group in the current Chart app instance or create a **New waypoint**.

Use the **Multi-edit** option to make the same change to multiple Waypoints (e.g. change symbol, delete waypoints or move to a different group).

Select a waypoint to view its details.

Waypoint details

Waypoint 4

Name: Waypoint 4 Delete

Symbol: Go to

Group: FISHING

Position: 26°40'.323 N 077°46'.672 W

Bearing: 079.9°T Range: 1.04nm

Water temp: -- Depth: --

Time: 12:41:25am Date: 05/18/2017

Comment: Good fishing

The details for the waypoint can be customized by selecting the relevant field. You can also **Delete** the waypoint, set a **Goto**, or **View on chart**.

7.2 Routes

Routes are used to plan your journey in advance. You can plan your journey directly on your MFD, or at home using software capable of exporting Waypoints and Routes in standard .gpx format, such as Raymarine's Voyage Planner software.

Routes consist of a number of waypoints. Your MFD can store up to 250 Routes, each Route consisting of up to 500 waypoints. The Route capacity limit is subject to your MFD's 10,000 Waypoint limit (for example, your MFD could store 20 Routes each containing 500 waypoints).

Creating a Route



1. Select and hold on the location for the first waypoint.
2. Select **Build route** from the context menu.
3. Select the location for the second waypoint.
The 2 waypoints will be joined by a line, creating the first leg of your route.
4. Select the location for subsequent waypoints.
5. Check your Route will be safe to follow, you can move the waypoints in your route by dragging them to a new location.
6. When your Route is complete select **Finish route build**.

Use Autorouting during route creation

Whilst building a route you can use Autorouting to automatically add a route leg to a route you have already started to create. The Autorouting features require compatible cartography.

1. Press and hold anywhere on screen and select either **Autoroute to wpt** or **Autoroute to here**.

*Selecting **Autoroute to wpt** will allow you to select a waypoint from your Waypoints list to include in your route, selecting **Autoroute to here** will create a route leg to the cursor's current position.*

Once an Autoroute leg has been added you can select **Finish route build** or add further manual or autoroute route legs.

Autorouting

Autorouting is available when using compatible cartography. Autorouting allows you to build a route automatically between a point on the chart and your vessel.

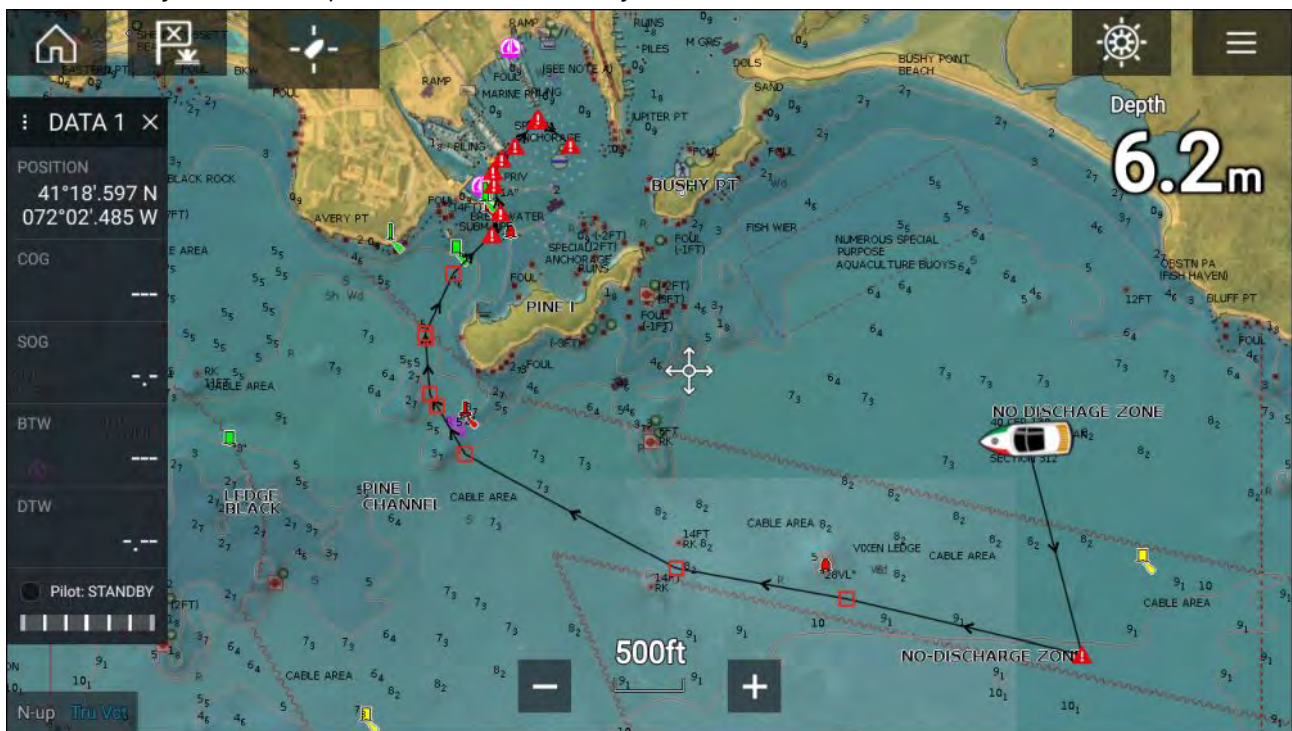

You can select any point on the Chart and from the Chart context menu select **Autoroute to here** or you can select **Autoroute to** from an existing waypoint's context menu to create a route automatically between your vessel and the chosen point.

The created route is generated by comparing data available on your cartography against the minimum safe distances specified in the **Boat details** menu: (**Homescreen > Settings > Boat details**).

Waypoints will not be placed in areas that conflict with your specified minimum safe distances.

Caution symbols are used for waypoints that are near objects or restricted areas.

Never follow a route before checking each route leg is safe for your vessel.

Reviewing an automatically generated route

Before following any route you must ensure that it is safe to do so.

Upon Route completion:

1. Range in on each route leg and waypoint that make up the Route.
2. Check either side of the route leg and around the waypoint for any possible obstructions.

Obstructions can be charted objects or restricted areas. Routes generated automatically should use the caution waypoint symbol in areas where there are possible obstructions.

3. Where obstructions exist move the necessary waypoints so that the waypoint and route leg is no longer obstructed.

Importing a route

You can import routes created in standard gpx format.

1. Save your route to a memory card.
2. Insert the memory card into your MFD.
3. Select Import from card from the Import/export page: **Homescreen > My data > Import/export > Import from card.**
4. Locate and select the gpx file that contains your Route.
The Route will be imported to your MFD.

Route management

Routes are managed using the Route list.

The Route list can be accessed from the Homescreen and from the Chart app: **Homescreen > My data > Routes**, or **Chart app > Menu > Waypoints, routes, tracks > Routes**.

If the Route list is accessed from the Chart app menu, then the selected route is displayed in a Chart pane on the right of the screen.

Route list

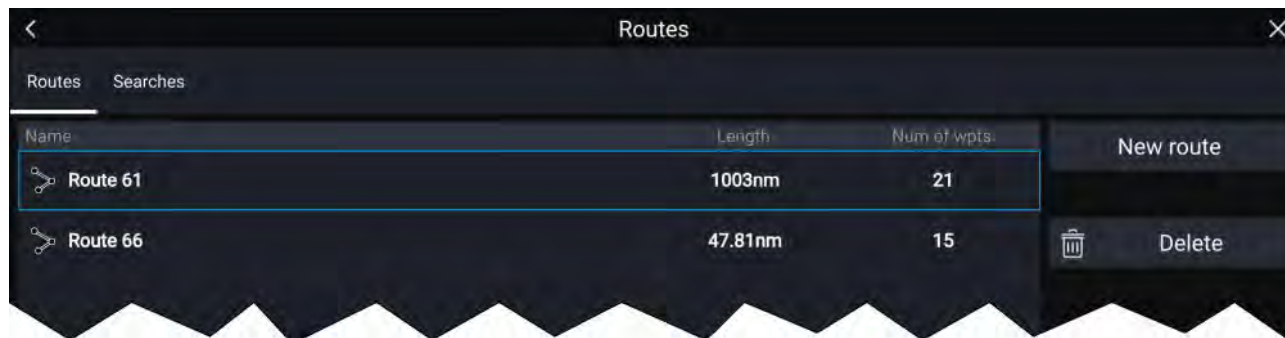

Name	Length	Num of wpts.	
Route 61	1003nm	21	New route
Route 66	47.81nm	15	Delete

From the route list you can **Delete** routes or create a **New route** using existing waypoints.

To view a route plan, select a route and choose **View route plan**.

Route plan

The route plan displays a list of all waypoints in the route and when accessed from the Chart app also includes a Chart pane showing the route's location.

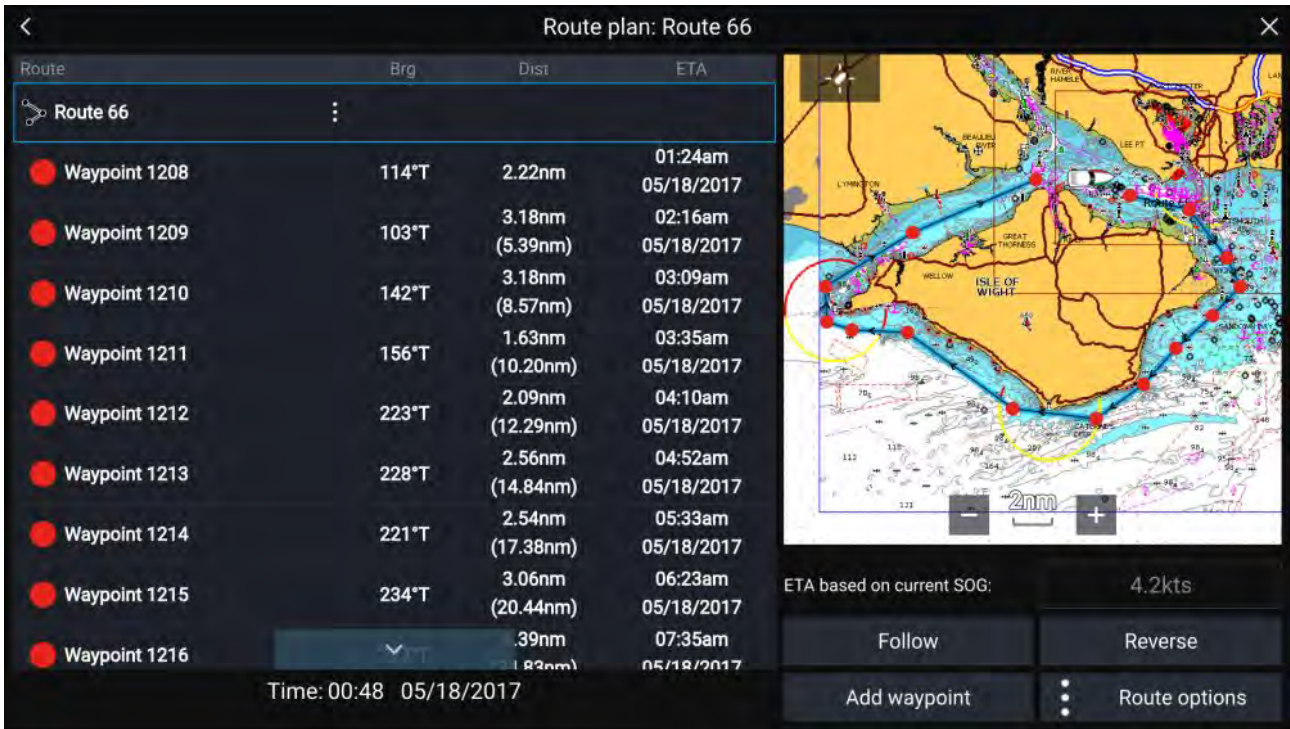

From the Route plan you can:

- navigate the route by selecting **Follow**
- change the route direction by selecting **Reverse**
- add an existing waypoint to the route by selecting **Add waypoint**
- change route options by selecting **Route options**

By selecting a waypoint from the route plan you can change the waypoint order by moving the waypoint up and down the list. You can also remove the waypoint from the list, delete the waypoint, edit the waypoint details or start the Route follow from any waypoint in the route.

Route options

Rename route	Give the route a name.
Color	Change the color of the route, as displayed in the Chart app.
Time	Switch the time between ETA (Estimated Time of Arrival) and TTG (Time To Go).
Speed	Switch the speed between Actual (SOG) and Planned . When the speed is set to Planned you can select a desired speed for navigating the route.
Hide/show on chart	Choose whether the Route should be displayed in the Chart app or not.
Export	Export the route to a memory card.
Delete route	Delete the route.

7.3 Tracks

Tracks are used to record where you have been. Tracks are made up of track points that are created at regular time or distance intervals. You can store up to 15 tracks on your display, each track can contain up to 10,000 points.

Tracks can be converted into routes so that they can be followed.

Creating a track

You can record your vessel's journey using Tracks.

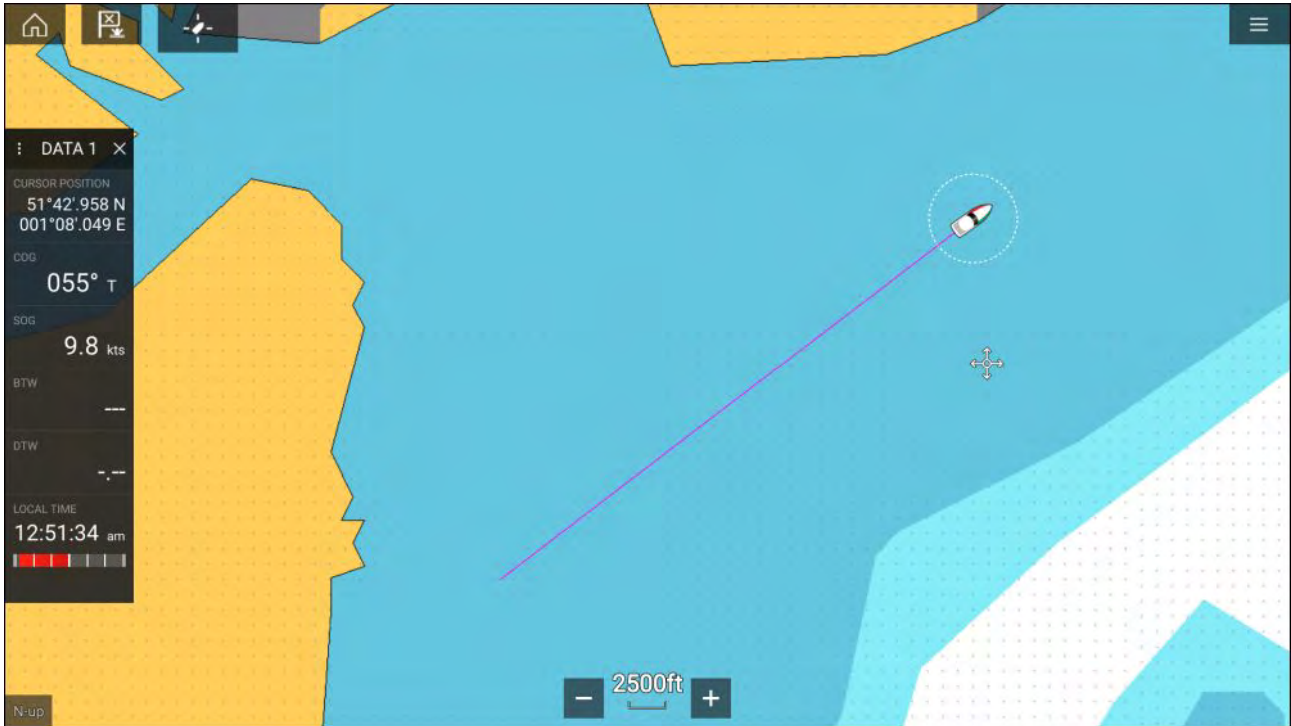

1. Select and hold on your vessel icon to display the vessel pop-over options.
2. Select **Start track**.
Your vessel's journey will now be recorded.
3. Select **Stop track** from the pop-over options when you have completed your track.
4. Select **Save** to save the track or **Delete** to remove the track.

You can also start a new track recording at anytime from the Chart menu: **Menu > New > Start a new track**. When using the Chart menu to start a track, if a track is already recording then it will be saved before the new track is started. Once a Track is saved it can be converted to a Route so that the same passage may be followed again at a later date.

Converting a track to a route

From the Track list: **Menu > Waypoints, routes, tracks > Tracks**.

1. Select a track.
2. Select **Create route from track** from the pop-over options.
3. Select **OK**.

Track management

Tracks are managed using the Track list.

The Track list can be accessed from the Homescreen and from the Chart app: **Homescreen > My data > Tracks**, or **Chart app > Menu > Waypoints, routes, tracks > Tracks**.

If the Track list is accessed from the Chart app menu, then the selected track is displayed in a Chart pane on the right of the screen.

Track list



From the track list you can Start or Stop tracks recording, **Delete** a track or choose how tracks are recorded.

Track interval

The track interval determines the time period or distance between track points when recording a track. You can choose whether to record track points by Time, by Distance or set to Auto.

- In **Auto** the track interval is set automatically to minimize the track points used whilst maintaining the actual path taken.
- When set to **Time**, you can choose a specified time period between track points.
- When set to **Distance** you can choose a specified distance between track points.

Customize tracks

From the Track pop-over options you can:

- rename a track
- change track color
- create a route from a track
- delete a track
- hide/show the track in the Chart app.

Chapter 8: Chart app

Chapter contents

- 8.1 Chart app overview on page 106
- 8.2 Navigation on page 113
- 8.3 SAR (Search and Rescue) Patterns on page 114
- 8.4 Laylines on page 122
- 8.5 Race Start Line (SmartStart) and Race Timer on page 127
- 8.6 Target tracking on page 132
- 8.7 Collision avoidance on page 140
- 8.8 Target intercept on page 149
- 8.9 Tides mode on page 150
- 8.10 RealBathy™ on page 154
- 8.11 Find nearest on page 156
- 8.12 SonarChart™ Live on page 158
- 8.13 UAV Chart integration on page 159
- 8.14 ClearCruise™ Augmented Reality on page 160
- 8.15 Chart settings menu on page 161

8.1 Chart app overview

The Chart app displays a representation of your vessel in relation to land masses and other charted objects, which enables you to plan and navigate to your desired destination. The Chart app requires a GNSS (GPS) position fix in order to display your vessel at the correct location on a world map.

For each instance of the Chart app you can select which electronic cartography you want to use. The selection will persist over a power cycle.

The Chart app can be displayed in both fullscreen and splitscreen app pages. App pages may consist of up to 4 instances of the Chart app.



1	Waypoint Use waypoints to mark specific locations or points of interest.	2	Track You can record the passage your vessel takes using Tracks.
3	Vessel icon This icon represents your vessel, only displayed when a GNSS (GPS) position fix is available. The icon will be a black dot if no Heading is available).	4	Wind indicator Provides indication of wind direction and speed (Wind transducer required).
5	Route You can plan your route in advance by creating a Route using Waypoints to mark each route leg.	6	Destination waypoint During a Goto, this is the current destination waypoint.
7	Heading line If Heading data is available, a Heading vector for your vessel can be displayed.	8	COG line If COG data is available, you can display a COG vector for your vessel.

9	Tide indicator Provides tide Set and Drift indicators. Requires the following data: COG, Heading, SOG, and STW (Speed Through Water).	10	Chart range Identifies the scale for the displayed Chart range.
11	Range rings Provides a distance indication around your vessel at set intervals.	12	Sidebar The Sidebar contains system data that can be viewed in all apps.

Chart app controls







Icon	Description	Action
	Home icon	Takes you to the Homescreen
	Waypoint / MOB	Place waypoint / hold down to activate Man overboard (MOB) alarm
	Pilot icon	Opens and closes the Pilot Sidebar
	Menu icon	Opens the app menu
	Find vessel	Centers your vessel onscreen.
	Range In	Decreases the range/distance displayed onscreen.
	Range Out	Increases the range/distance displayed onscreen.

Chart ranging and panning

You can change the range displayed in the Chart app using the onscreen Range controls or by using the pinch-to-zoom multi-touch gesture.

You can pan the chart area by swiping your finger across the chart.

Chart app context menu

Context menus provide context sensitive menu options.

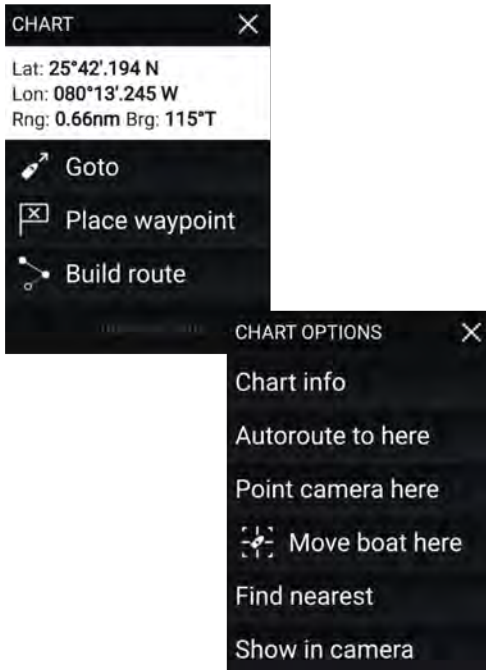

- Context menus are accessed in the Chart app by pressing and holding on a location or object.
- The context menu provides Latitude, longitude, range and bearing details for the selected location or object.
- The context menu provides quick access to relevant settings or features.
- Select **More options** to display further options.

Note:

The **Move boat here** option is only available in Demo/simulator mode.

Selecting a chart card

You can use LightHouse™ charts and compatible Navionics and C-MAP electronic charts. The electronic chart cards must be inserted into the MFD's MicroSD card reader (or the card reader of an MFD on the same network).

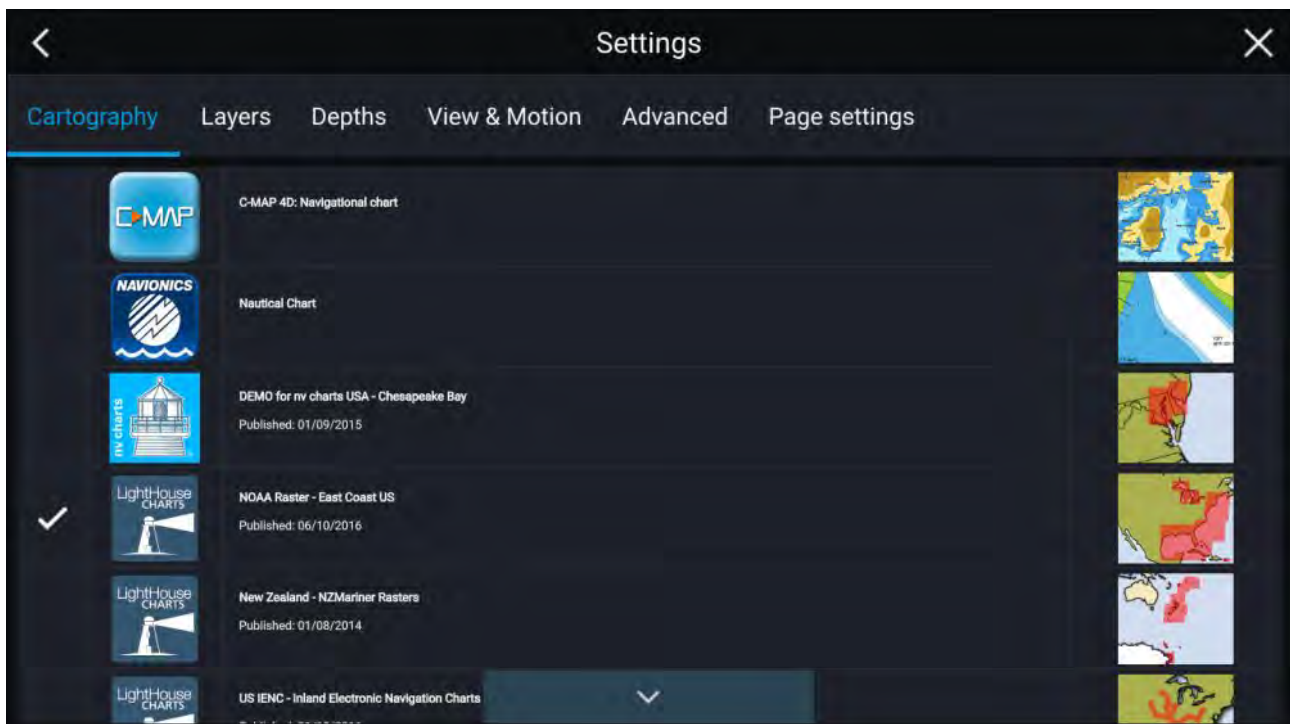

From the Chart app menu:

1. Select the **Settings** icon.
2. Select the cartography that you want to use from the Cartography tab.

You may choose a different chart for each instance of the Chart app, accessed from the Homescreen. Cartography selection will persist until changed.

Chart modes

The Chart app provides preset modes that can be used to quickly set up the Chart app for your intended use.

To change Chart mode select the required mode from the app menu.

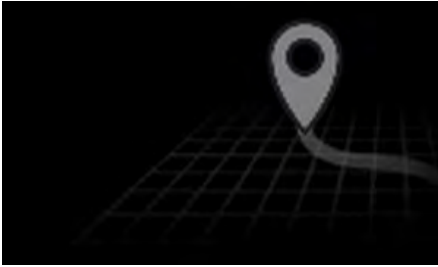

SIMPLE

In Simple mode, chart detail is suppressed to provide a clearer, simpler view for navigation and only navigation related menu options are available. Settings changes are not saved.



DETAILED

Detailed is the default mode. Full chart detail and menu options are available. Settings changes are saved to the user profile in use.



FISHING CHART

Fishing mode optimizes the Chart app for Fishing and if supported by your selected cartography, displays more detailed contour lines. Full menu options are available. Settings changes are saved to the user profile in use.



WEATHER

Weather mode is available when the MFD is connected to a compatible Weather receiver (SR150).

Weather mode allows you to overlay weather data directly on the chart and view animated weather graphics or read weather reports. Only Weather related menu options are available. Settings changes are saved to the user profile in use.

For further details on Weather mode refer to: [Chapter 9 Weather mode](#)



TIDES

In Tides mode, Tide Station and Current Station icons are replaced with graphics representing Tide and Current conditions. Animation controls are displayed that enable playback of Tide and Current predictions over a 24 hour period.

Tides mode also suppresses chart detail, to enhance the Tide and Current graphics and enables own vessel Tide vector graphics.



RACING

Racing mode optimizes the Chart app for Race Sailing.

Racing mode is available when the MFD is setup with Sailing as the boat activity.

In Racing mode, Race Start Line and Race Timer options become available from the menu, allowing you to create a start line and countdown timer which can help optimize your racing start.

Vessel details

The Vessel details pop-over provides access to vessel-related settings.

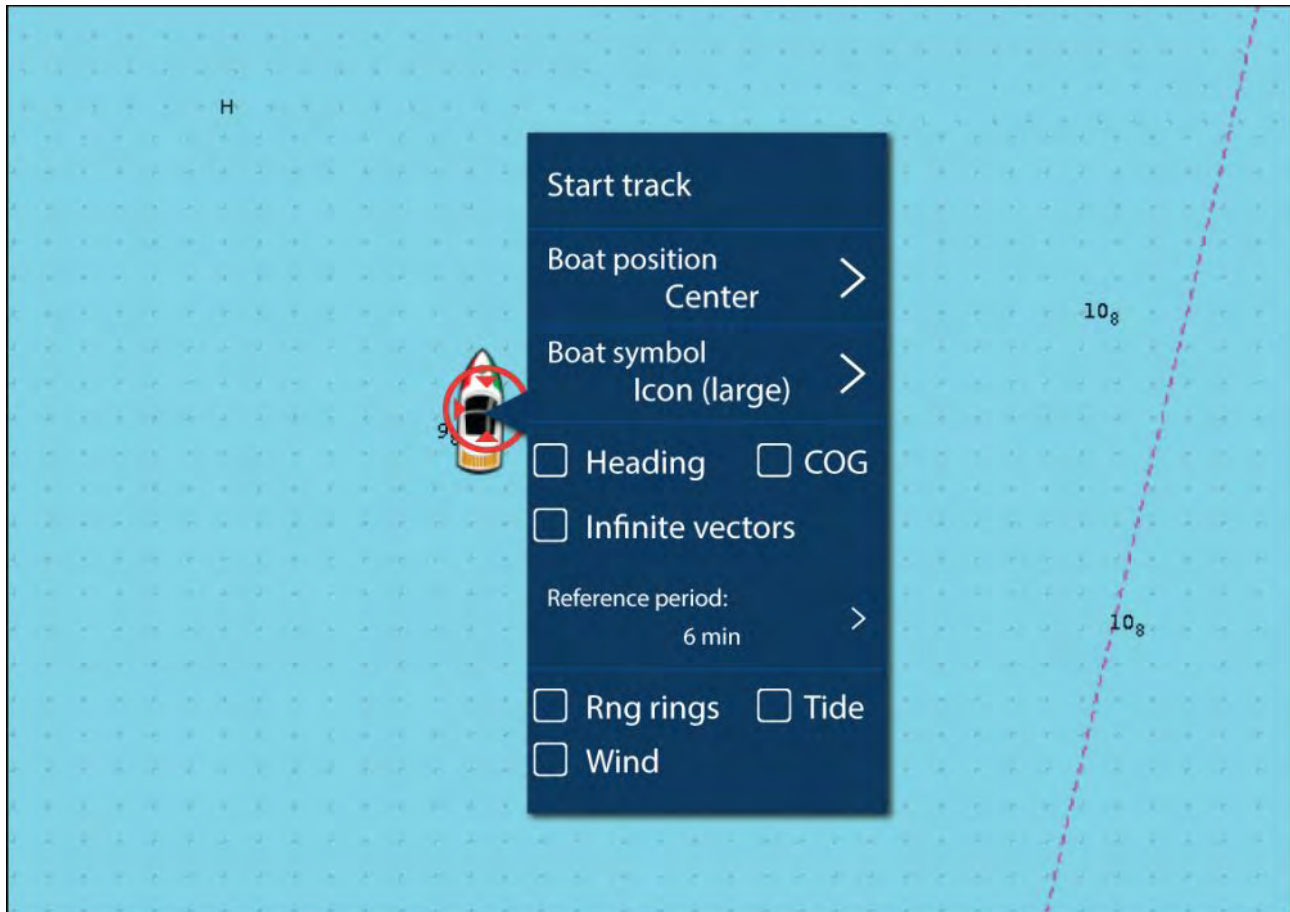

From the Vessel details pop-over you can:

- start/stop a track.
- offset the position of the vessel symbol.
- change the symbol used to represent your vessel.
- set the length of vessel vectors.
- show / hide Heading and COG vectors.
- show / hide Range Rings.
- show / hide Tide and Wind graphics.

Note:

In **Simple mode**, the only option available is Start/stop track.

Object selection and information

Charted objects, available on your cartography can be selected and object information can be viewed.



When you select an object the cursor will change to the Object cursor.

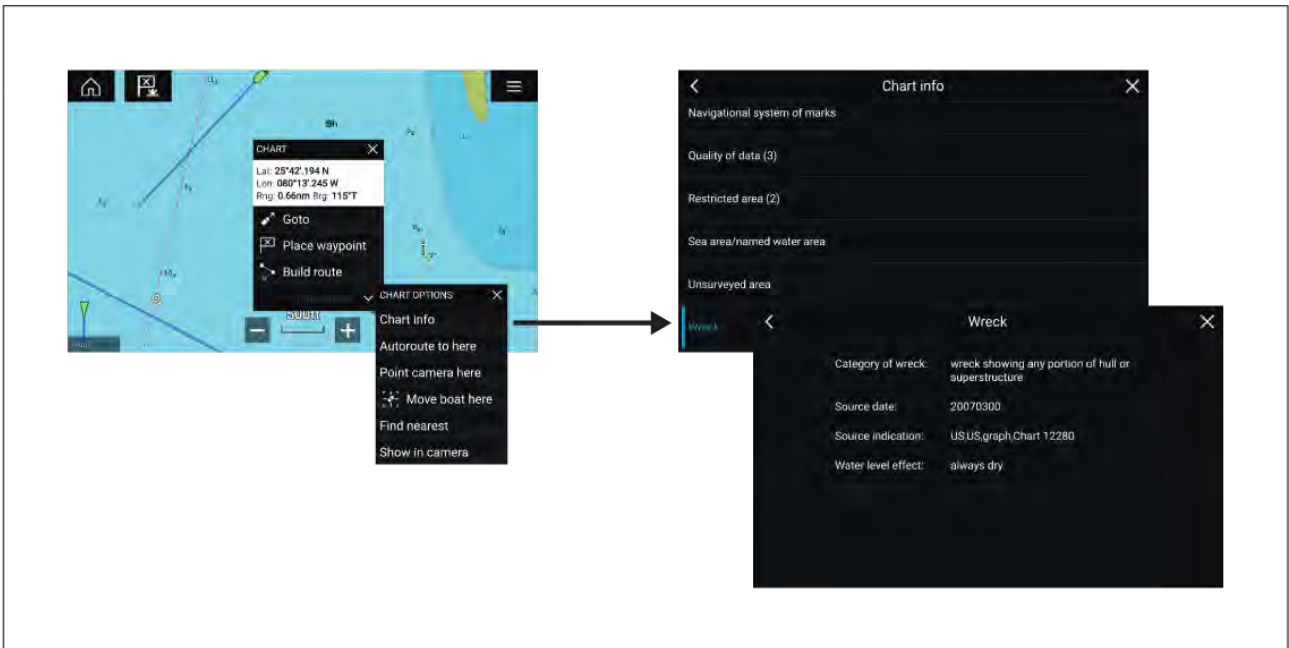

Selecting and holding on the object will display the object context menu.

From the context menu select: **More options** > **Chart info** and then select the object from the list to view its details.

In areas where there is a high concentration of charted objects, selecting **Nearby objects** from the context menu will display a list of objects located nearby for you to choose from.

Layers

Layers are additional data views that can be overlaid (superimposed) on the Chart app. Types of layer include: aerial photographs, AIS targets, Radar image, range rings, tide graphs, weather Radar and crowd-sourced content.

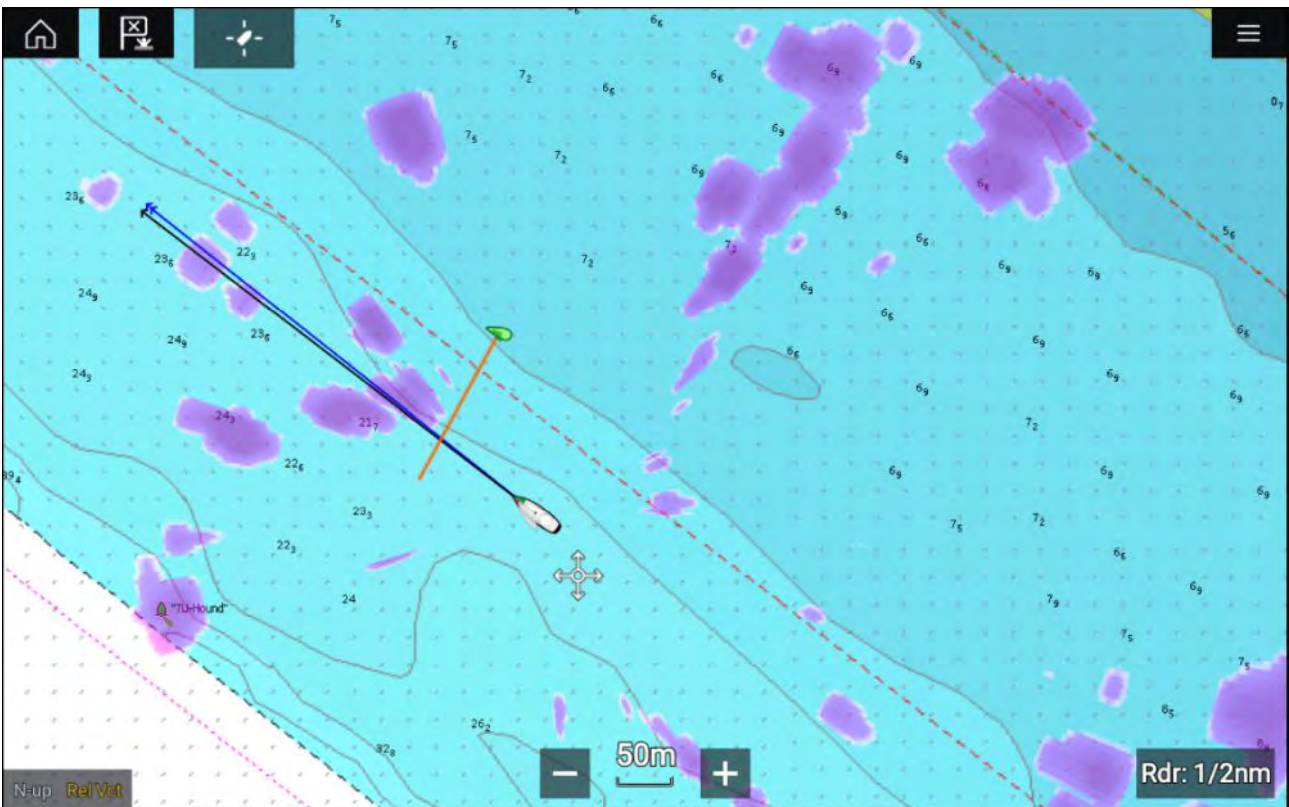

The Layers tab in the Chart app Settings menu provides controls for the Chart layers: **Menu** > **Settings** > **Layers**.

View and motion

The view and motion tab allows you to control how the chart is displayed in relation to your vessel.

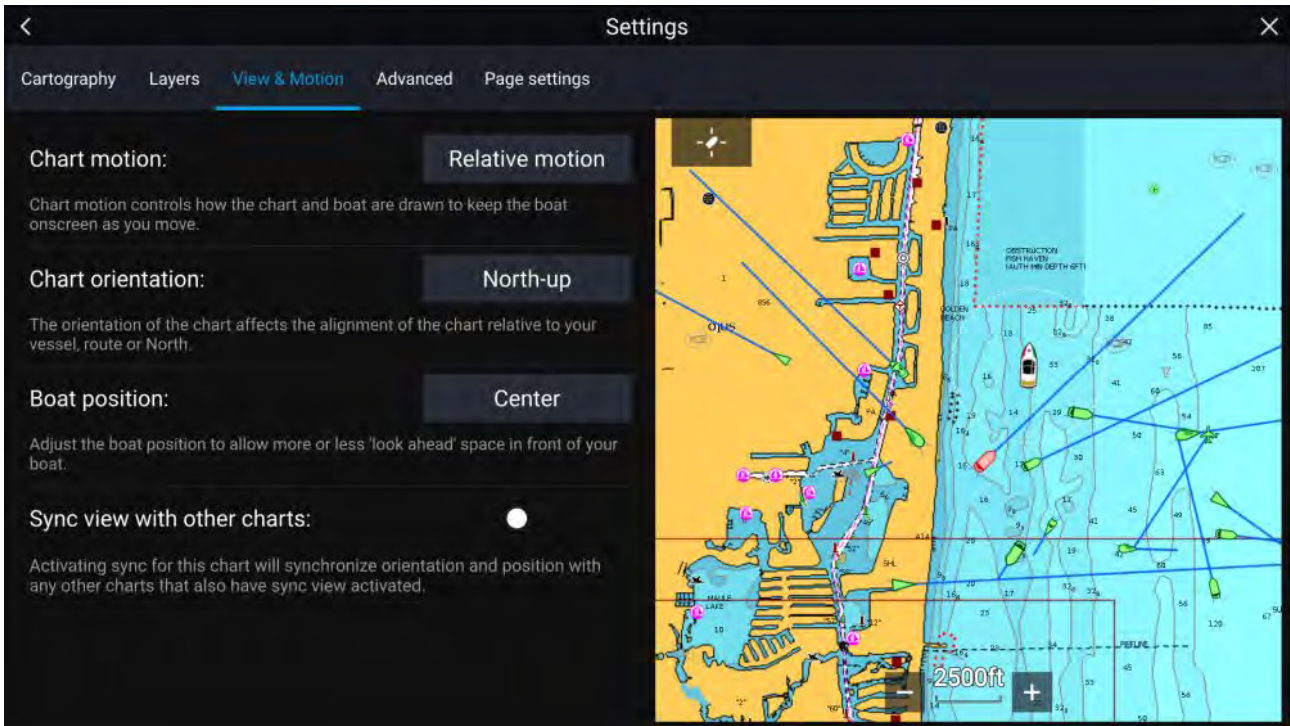

Chart motion

Chart motion controls how the chart and boat are drawn to keep the boat onscreen as you move.

Chart orientation

The orientation of the chart affects the alignment of the chart relative to your vessel, route or North.

Boat position

Adjust the boat position to allow more or less 'look ahead' space in front of your boat.

Sync view with other charts

Synchronize the orientation and position of all charts that have this setting enabled.

Camera tracking

When connected to a compatible Pan and Tilt Thermal camera you can track targets or point your camera at a specific target or area.

2 options are available for camera tracking:

- **Point camera here** — Points the camera at a specific point onscreen, the camera will remain pointed at this area regardless of your own vessel's course.
- **Track with camera** — Tracks a selected target regardless of your own vessel's or target's course.

Camera tracking options are available from the Context menu in the Chart and Radar apps: **Context menu > more options > Point camera here**, or **Context menu > more options > Track with camera**.

Automatic tracking

You can use the Camera app settings to configure automatic tracking for AIS, Radar and MoB targets: **Camera app > Menu > Settings > Camera motion > AUTO TRACKING**

8.2 Navigation

Navigating to a waypoint or point of interest

You can perform a “Goto” to a Waypoint or specific location.



1. Select and hold on the waypoint or point of interest and select **Goto** from the context menu.

*You can stop the **Goto** at any time by selecting and holding anywhere in the Chart app and choosing **Stop**, or selecting another **Goto**.*

2. The Chart app will begin navigation, if required physically engage your autopilot.
3. An alarm will sound when you reach the waypoint.

You can also perform a Goto from the **Go** menu: **Menu > Go > Waypoint** or **Menu > Go > Lat/long**.

For more information on waypoints and waypoint management refer to: [Chapter 7 Waypoints, Routes and Tracks](#)

Restarting cross track error (XTE)

A cross track error (XTE) occurs when your actual route diverges from your original planned route. Restarting XTE plots a new course directly from your current position to your destination, rather than continuing to follow the original planned route.

1. Select **Restart XTE** from the **Navigation** menu: **Menu > Navigation > Restart XTE**.

Following a Route

You can follow a saved route.

With the Route displayed in the Chart app:

1. Select and hold on a Route leg within the Route you want to follow.
2. Select **Follow Route** from the Route context menu.

8.3 SAR (Search and Rescue) Patterns

Attempting to search the water for an object can be challenging, due to the vastness of the ocean and the effects of tide. Additionally, the object you are searching for is not normally in its last known location.

SAR Patterns are routes that can help you find an object in the water. The pattern can be modified and can take the effects of the tide into account, providing a more accurate and consistent route to search. SAR Patterns can be created on your MFD in the **Chart app**.



Access search pattern options: **Chart app > Menu > New > Search patterns.**

The available Search Patterns are:

- Sector Search
- Creeping line
- Parallel Line

Once a search pattern is created it is saved as a Route and can be managed and navigated in the same manner as any other saved Route. For more information refer to: [7.2 Routes](#)

Sector search pattern

The Sector Search pattern is made up of 9 legs, with the 3rd, 6th and 9th leg running past the datum (the Track Spacing will change depending on whether you are with or against the drift).

Note: As the Search patterns take in to account drift, the resulting Route may not resemble the patterns shown.

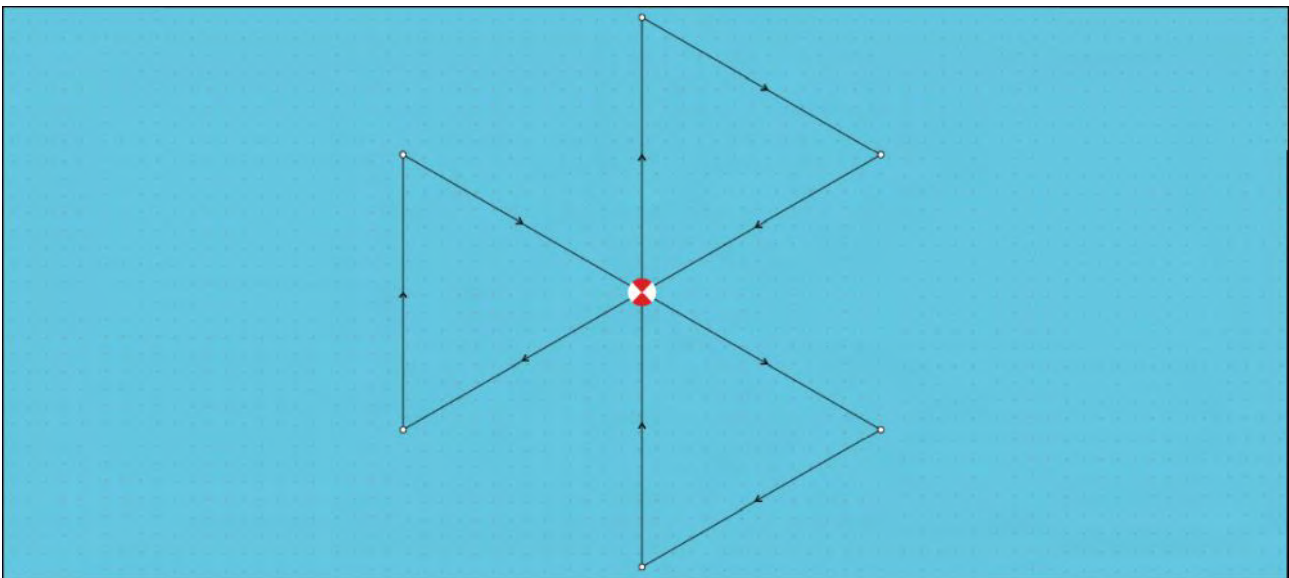

Creating a sector search pattern

To create a Sector Search pattern follow the steps below:

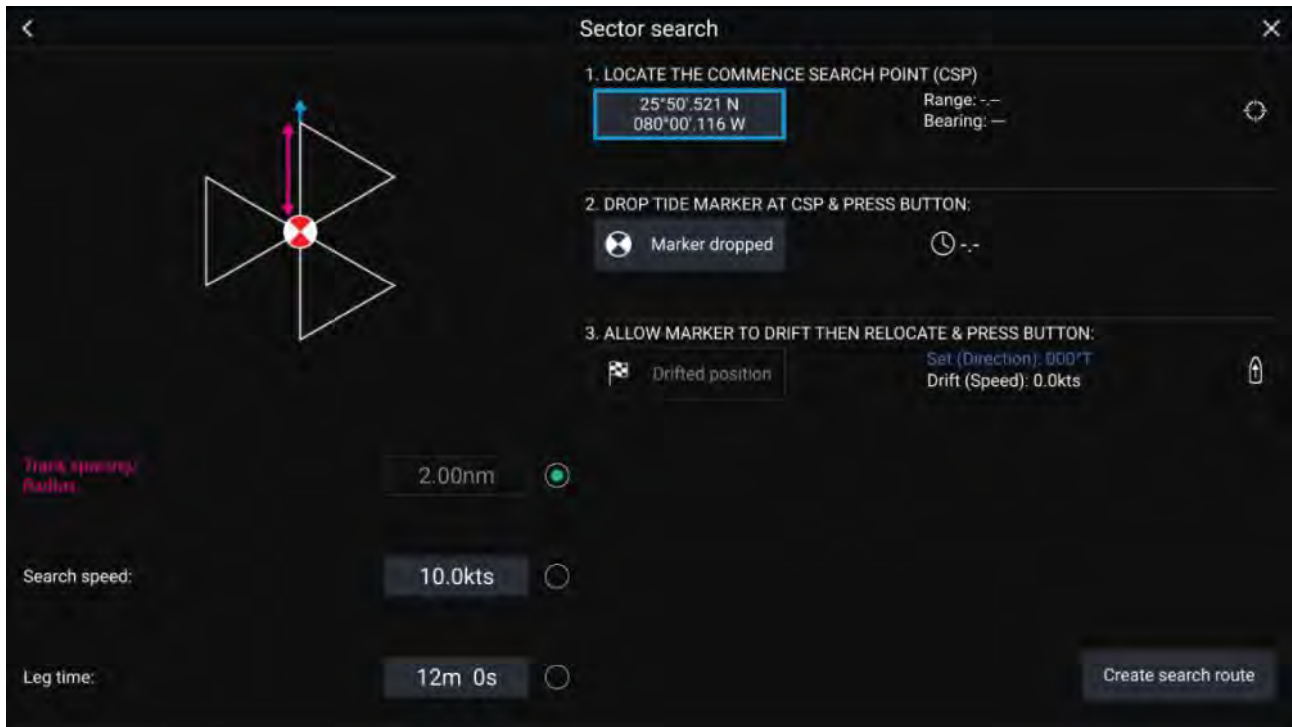

1. Set Commence Search Point (CSP)

- Manually input the **CSP** coordinates; a **Range** and **Bearing** are displayed to direct your vessel towards it.
- Alternatively, set the **CSP** as your vessel's current location by selecting the ⁽¹⁾ **CSP Shortcut** button.

2. Set Drift

- Drop the **Datum Marker** in the water and select **Marker dropped**.
- Wait for the **Datum Marker** to drift through the water.
- Return to the **Datum Marker** in the new location and select **Drift position** to calculate the **Set (Direction)** and **Drift (Speed)**.
- Alternatively, you can use your vessel's **Heading** and **SOG** to define the set and drift by selecting the ⁽²⁾ **Set / Drift shortcut** icon.

3. Set Track spacing / Radius, Search Speed, and Leg time

[All 3 variables are dependent on each other. One variable is always the product of the other two.]

- Select one of the variables by selecting the ⁽³⁾ **Output** icon.
- The selected variable will then be calculated as a result of changes made to the other two variables.

Variable	Maximum Value
Track spacing / Radius	5 nm / 5 sm / 5 Km
Search Speed	40 Kts / 46 Mph / 74 Kph
Leg Time	59m 59s

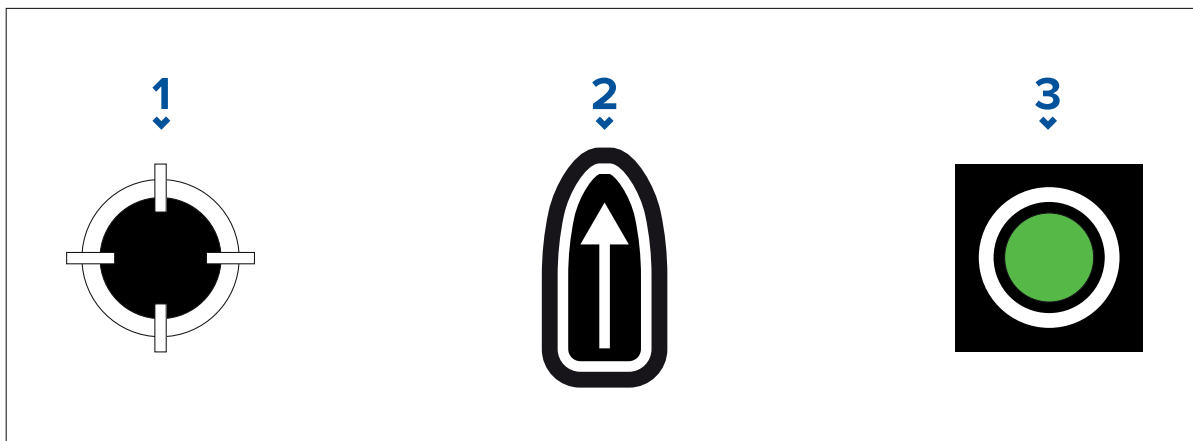

1. **CSP Shortcut**
2. **Set / Drift Shortcut**
3. **Output**

4. **Create search route**

[After all the above steps have been completed you can create your SAR pattern.]

- i. To create a search pattern, select the **Create search route** button in the bottom right of the screen.
- ii. The creation page will display your SAR pattern data and its location on the Chart app.

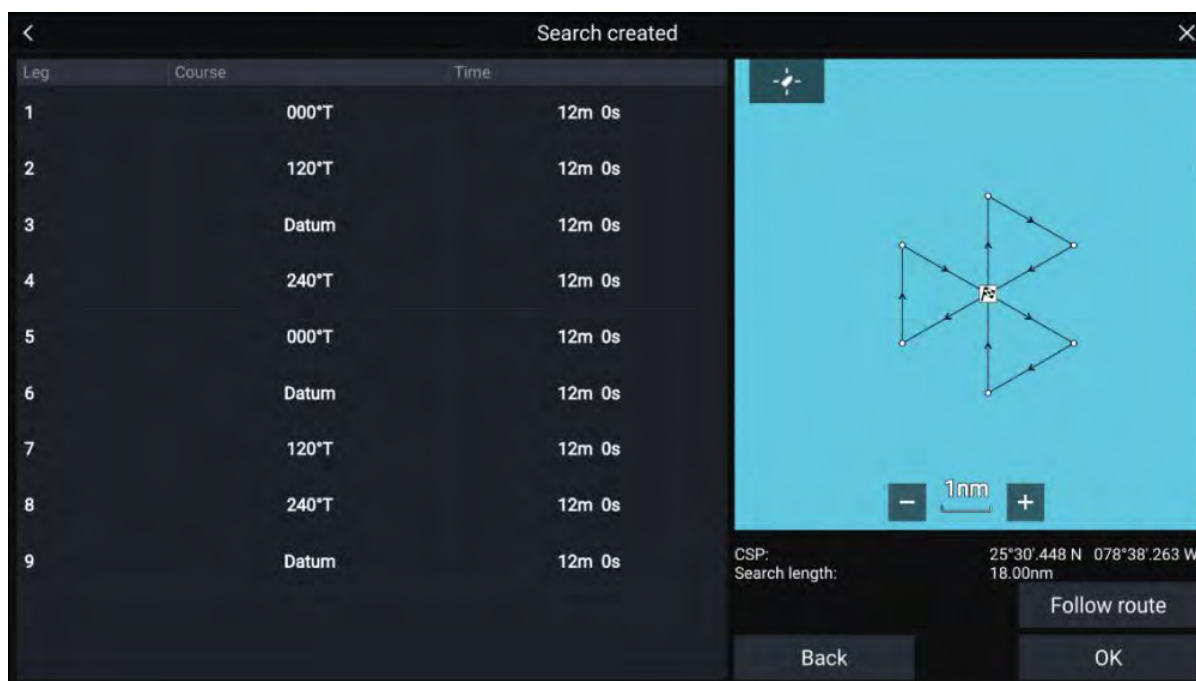

- iii. Select **Follow Route** to overlay the pattern on the **Chart app** and automatically follow the route.
- iv. Alternatively, select **OK** to overlay the pattern on the **Chart app** without following it.

Drift effects on sector search patterns

As the search patterns account for drift the resulting **Route** may not resemble the pattern shown above.

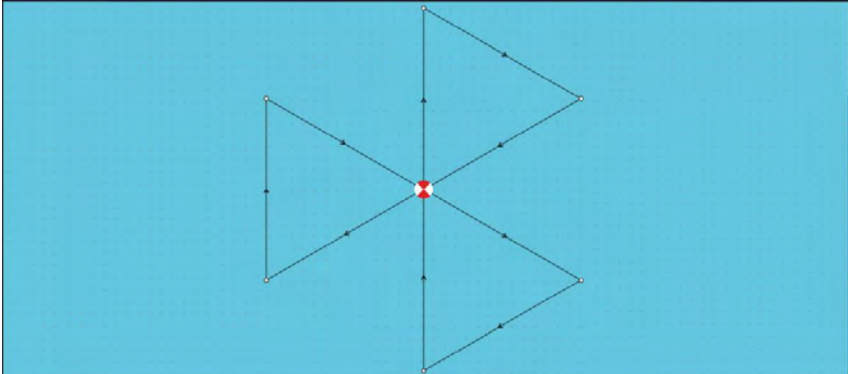
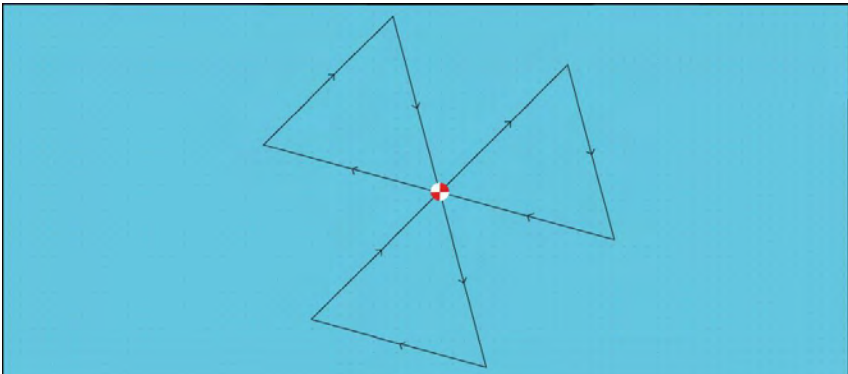
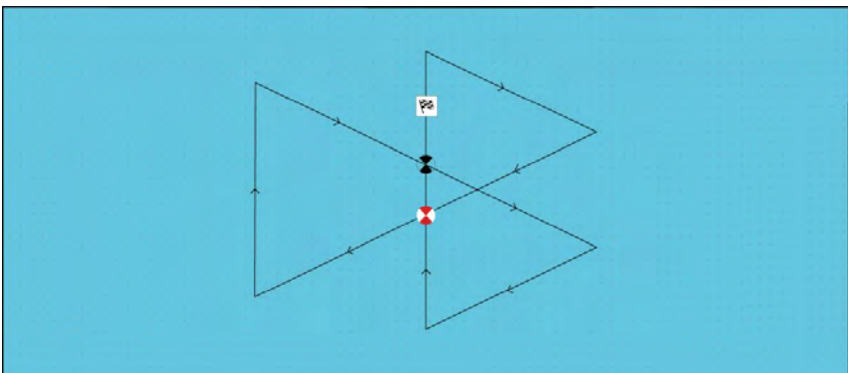
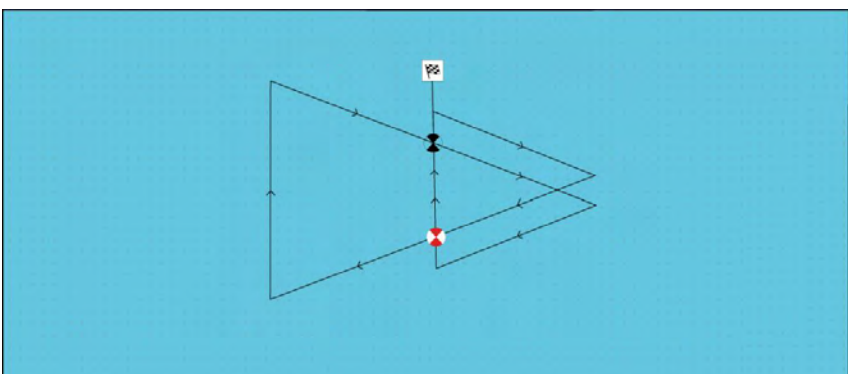
Example	Drift
	Direction: 0° Speed: 0 Kts
	Direction: 45° Speed: 0 Kts
	Direction: 0° Speed: 0.5 Kts
	Direction: 0° Speed: 1 Kts

Expanding square search pattern

The Expanding Square search pattern is an outwards spiralling square pattern, and is particularly suited to very detailed and methodical searches.

Note:

The Search patterns take drift into account, and therefore the resulting route may not resemble the patterns shown.

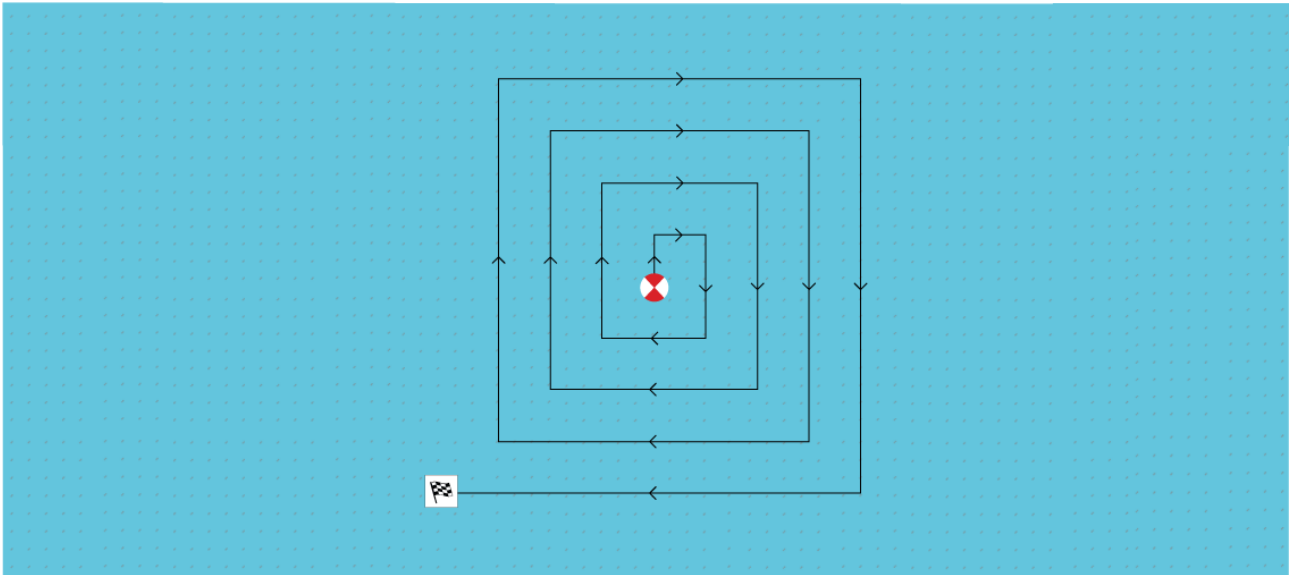

Creating an expanding square search pattern

To create a Expanding Square search pattern follow the steps below:

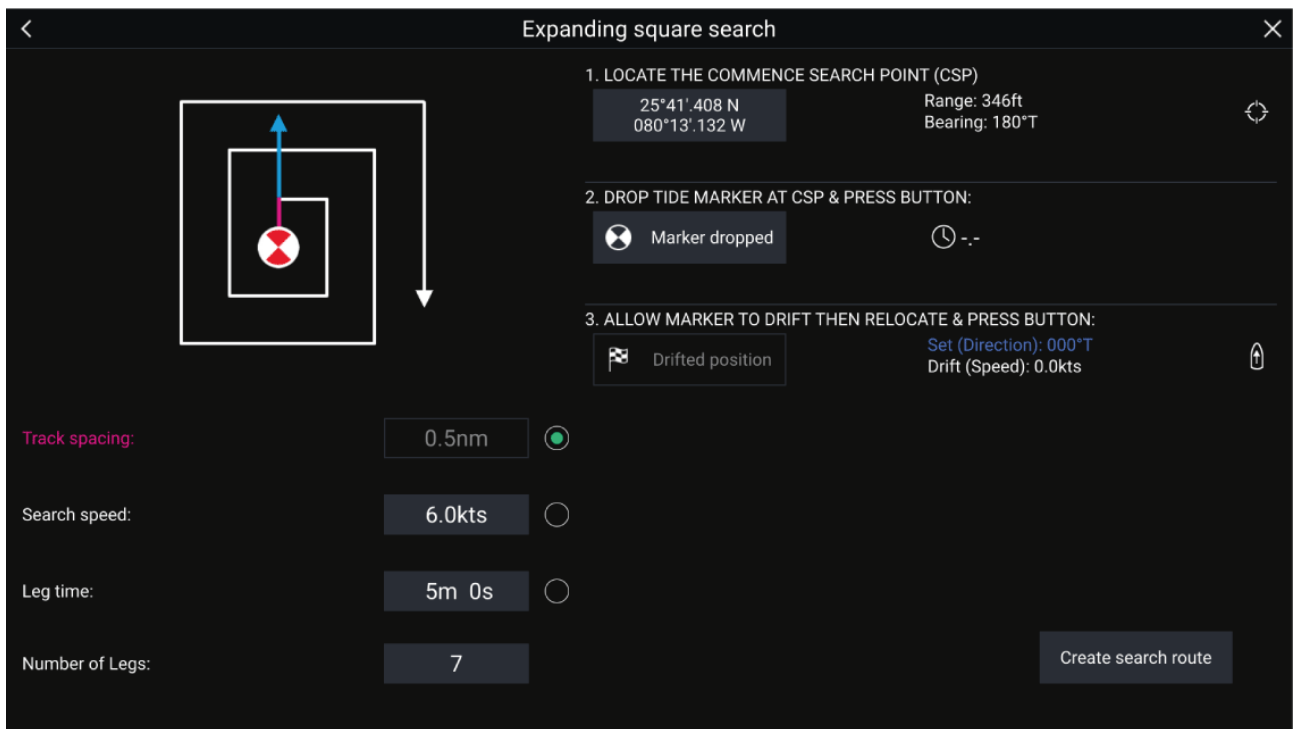

1. Set Commence Search Point (CSP)

- i. Manually input the **CSP** coordinates; a **Range** and **Bearing** are displayed to direct your vessel towards it.
- ii. Alternatively, set the **CSP** as your vessel's current location by selecting the ⁽¹⁾ **CSP Shortcut** button.

2. Set Drift

- i. Drop the **Datum Marker** in the water and select **Marker dropped**.
- ii. Wait for the **Datum Marker** to drift through the water.
- iii. Return to the **Datum Marker** in the new location and select **Drift position** to calculate the **Set (Direction)** and **Drift (Speed)**.
- iv. Alternatively, you can use your vessel's **Heading** and **SOG** to define the set and drift by selecting the ⁽²⁾ **Set / Drift shortcut** icon.

3. Set Track spacing / Radius, Search Speed, and Leg time

[All 3 variables are dependent on each other. One variable is always the product of the other two.]

- i. Select one of the variables by selecting the ⁽³⁾ **Output** icon.

- ii. The selected variable will then be calculated as a result of changes made to the other two variables.

Variable	Maximum Value
Track spacing / Radius	5 nm / 5 sm / 5 Km
Search Speed	40 Kts / 46 Mph / 74 Kph
Leg Time	59m 59s

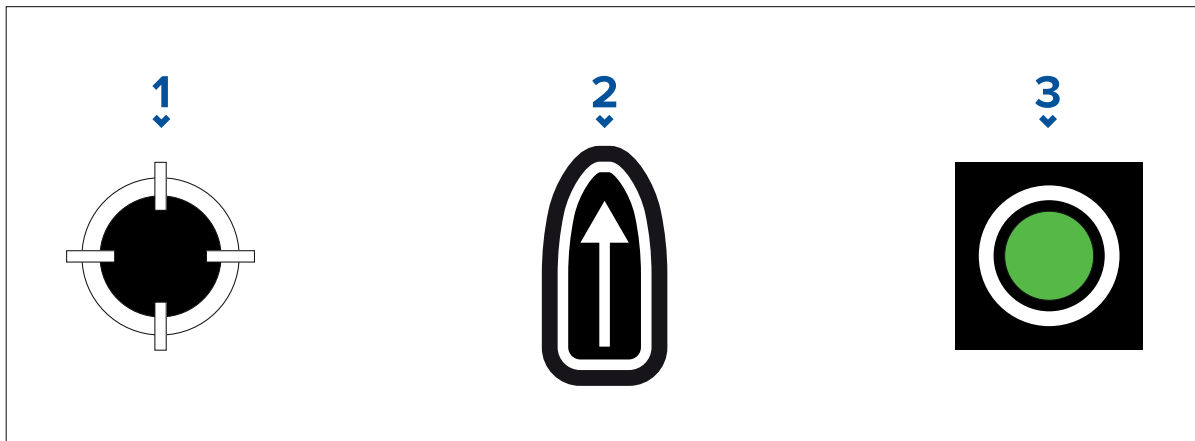

1. **CSP Shortcut**
2. **Set / Drift Shortcut**
3. **Output**
4. **Set the number of legs**
 - i. Select the number of legs for your expanding square search pattern.
5. **Create search route**

[After all the above steps have been completed you can create your SAR pattern.]

- i. To create a search pattern, select **Create search route** in the bottom right of the screen.
- ii. The creation page will display your SAR pattern data and its location in the Chart app.

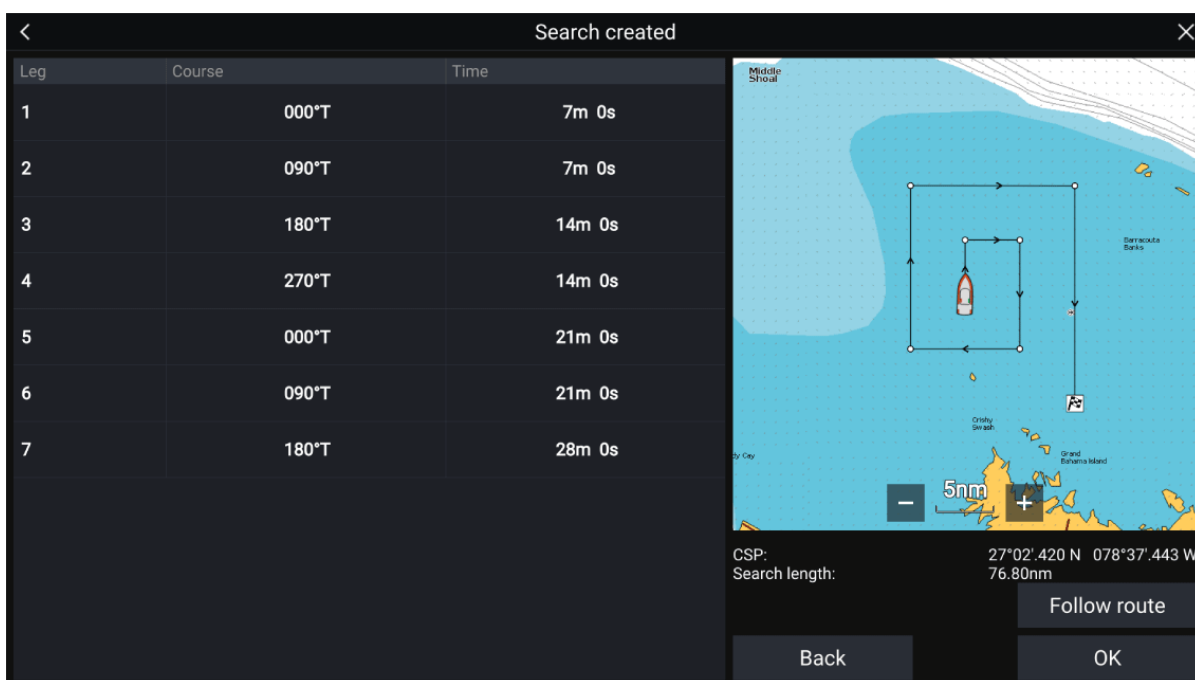

- iii. Select **Follow Route** to overlay the pattern on the Chart app and automatically follow the route.
- iv. Alternatively, select **OK** to overlay the pattern on the Chart app without following it.

Drift effects on expanding square search patterns

As the search patterns account for drift the resulting **Route** may not resemble the pattern shown above.

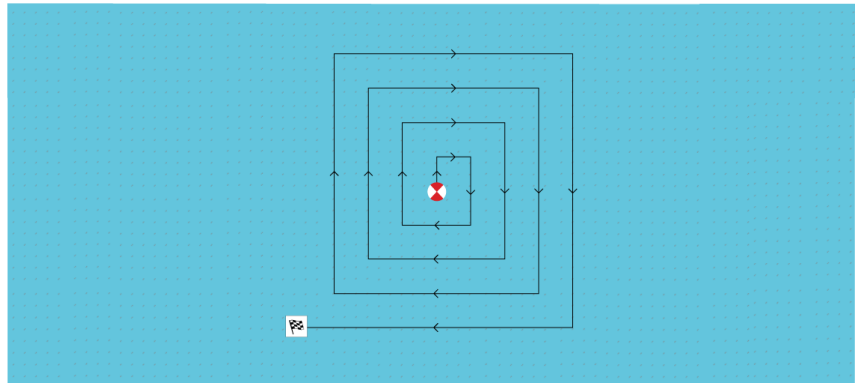
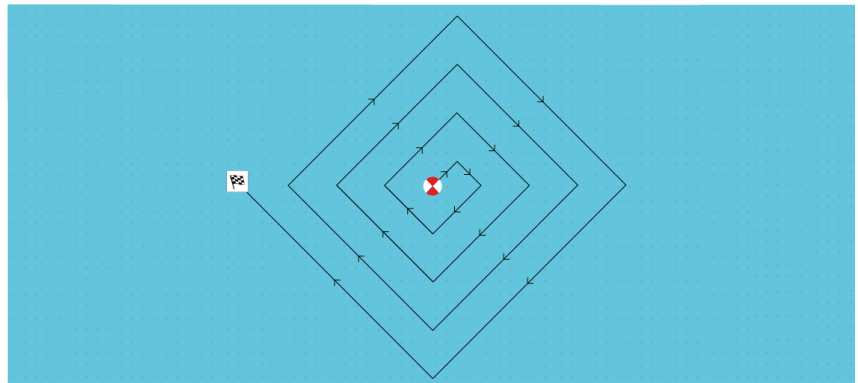
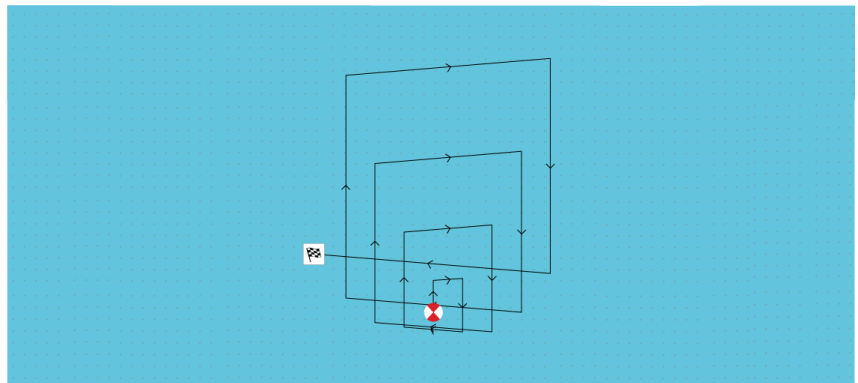
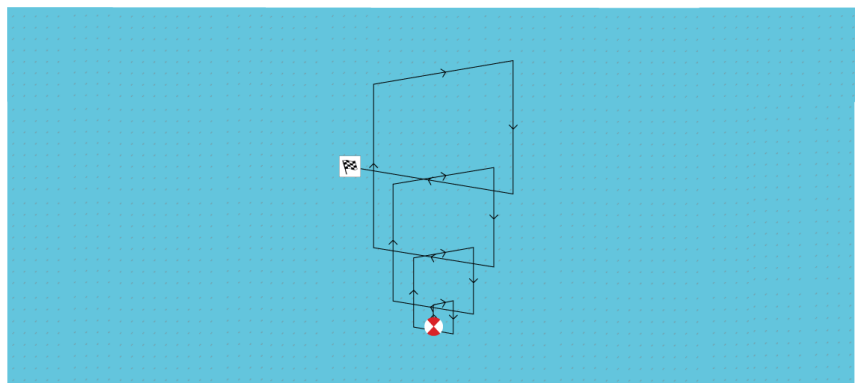
Example	Drift
	Direction: 0° Speed: 0 Kts
	Direction: 45° Speed: 0 Kts
	Direction: 0° Speed: 0.5 Kts
	Direction: 0° Speed: 1 Kts

Creeping line / Parallel line search pattern

The **Creeping / Parallel Line search pattern** covers a rectangular area. The area is searched either by starting at one end of the search area (Creeping), which provides greater coverage of one end but will take time to cover the whole area, or by searching the area lengthways (Parallel). This provides reasonable coverage of the area quickly.

The Creeping Line search should be used when there is a logical end of the search area to start your search from.

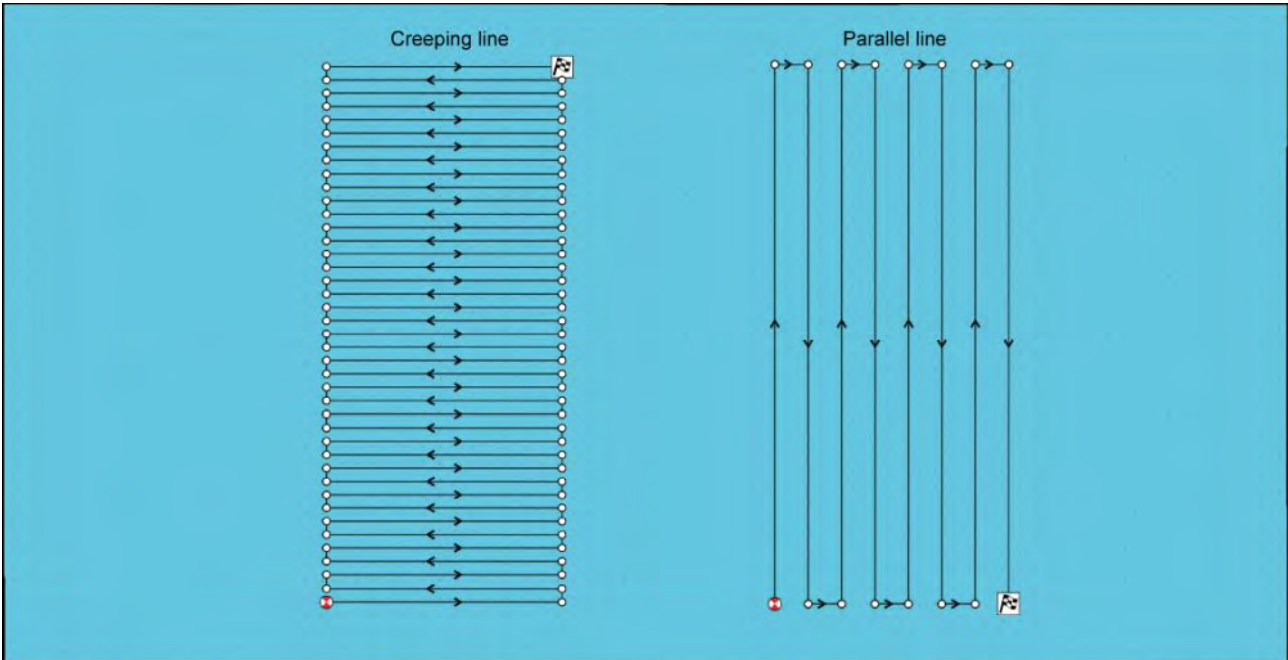

Creating a Creeping line / Parallel line search pattern

To create a Creeping line / Parallel line search pattern follow the steps below:

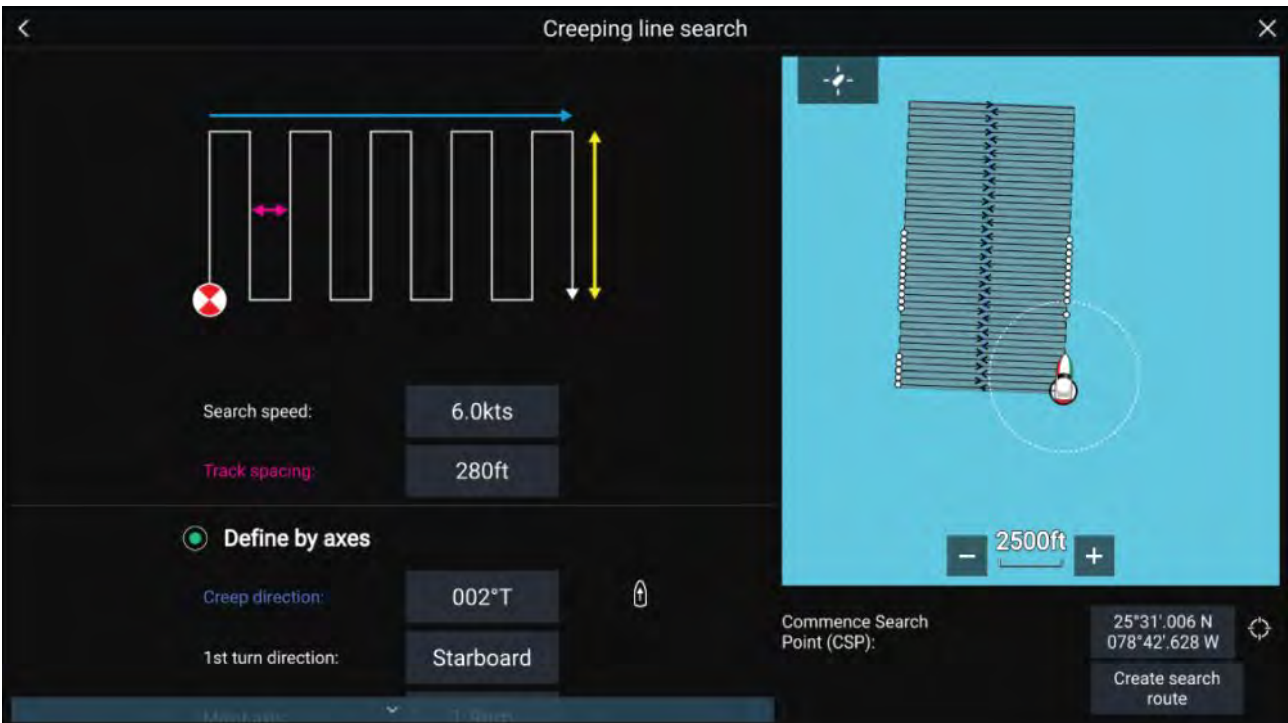

- 1. Set Commence Search Point (CSP)**
 - i. Manually input the **CSP** coordinates.
 - ii. Alternatively, set the **CSP** as your vessel's current location by pressing the ⁽¹⁾ **CSP Shortcut** button.
- 2. Set Search Speed, and Track Spacing**
 - i. Select and edit each variable.
- 3. Define Search Rectangle (Define by axes)**

- i. Define the rectangle's dimensions by using the **Major axis** and **Minor axis** boxes.
- ii. Set the **Creep / Parallel direction** manually or set it as your Vessel's heading by using the ⁽²⁾ **Shortcut** button.
- iii. Set the 1st turn direction by selecting **Port** or **Starboard**.

Variable	Maximum Value
Track spacing / Radius	5 nm / 5 sm / 5 Km
Search Speed	40 Kts / 46 Mph / 74 Kph
Major / Minor Axis	20 nm / 23 sm / 37 Km

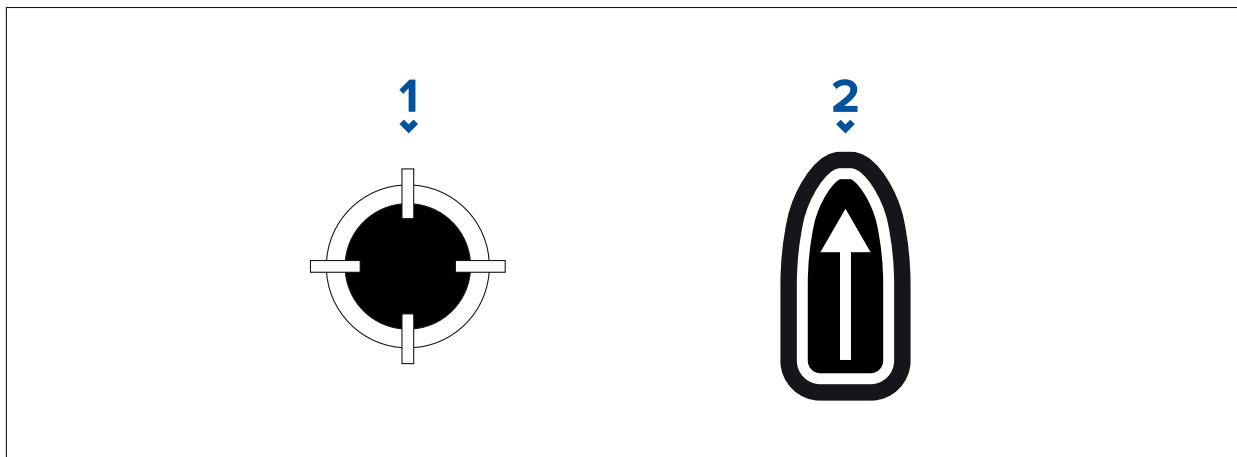

1. **CSP Shortcut**
2. **Creep / Parallel Direction Shortcut**

4. Define Search Rectangle (Define by corner points)

[If you would prefer to define the search rectangle dimensions using the major and minor axis, the rectangle can be defined by setting the coordinates of each corner point]:

- i. Enter the coordinates of each corner point 1–4.

Note:

- The corner coordinates need to form a rectangle. If the coordinates are not suitable then you will not be able to create the search route.
- The CSP must be on one of the sides of the search pattern.
- For a Creeping Line search pattern the CSP must be located along one of the longer sides.
- For a Parallel Line search pattern the CSP must be located along one of the shorter sides.
- The CSP must be on a bearing of between 85° to 95° (i.e. right angle \pm 5°) from the previous side.
- The CSP should be half a track width from the corner point.

8.4 Laylines

Laylines are used in sailing to show how far the vessel must sail on the current tack in order to make a target waypoint after tacking, given present wind conditions.

When a layline is used to calculate the route to a waypoint, it will take into account a number of factors to provide a better alternative course, compared to simply navigating in a straight line to a waypoint.

The reason why laylines are a more efficient way to sail to a specific point is because they're based on True Wind Direction (TWD) and either: a) fixed upwind / downwind sailing angles, or b) the use of polars to reflect the performance of your particular vessel. In this respect, sailing along laylines maximizes your Velocity Made Good (VMG) to windward. Another reason why laylines are more accurate is because they can also be configured to account for tidal current, as well as the leeway of your vessel.

To ensure the layline calculations are as accurate as possible, it's important to ensure that the following settings are correctly configured:

- **Boat details (specifically those relating to sailing):** **Homescreen > Settings > Boat details**
- **Laylines settings:** **Chart app > Menu > Settings > Laylines**

For more information on these settings, refer to: [p.77 – Boat details](#) and [p.124 – Laylines settings](#)

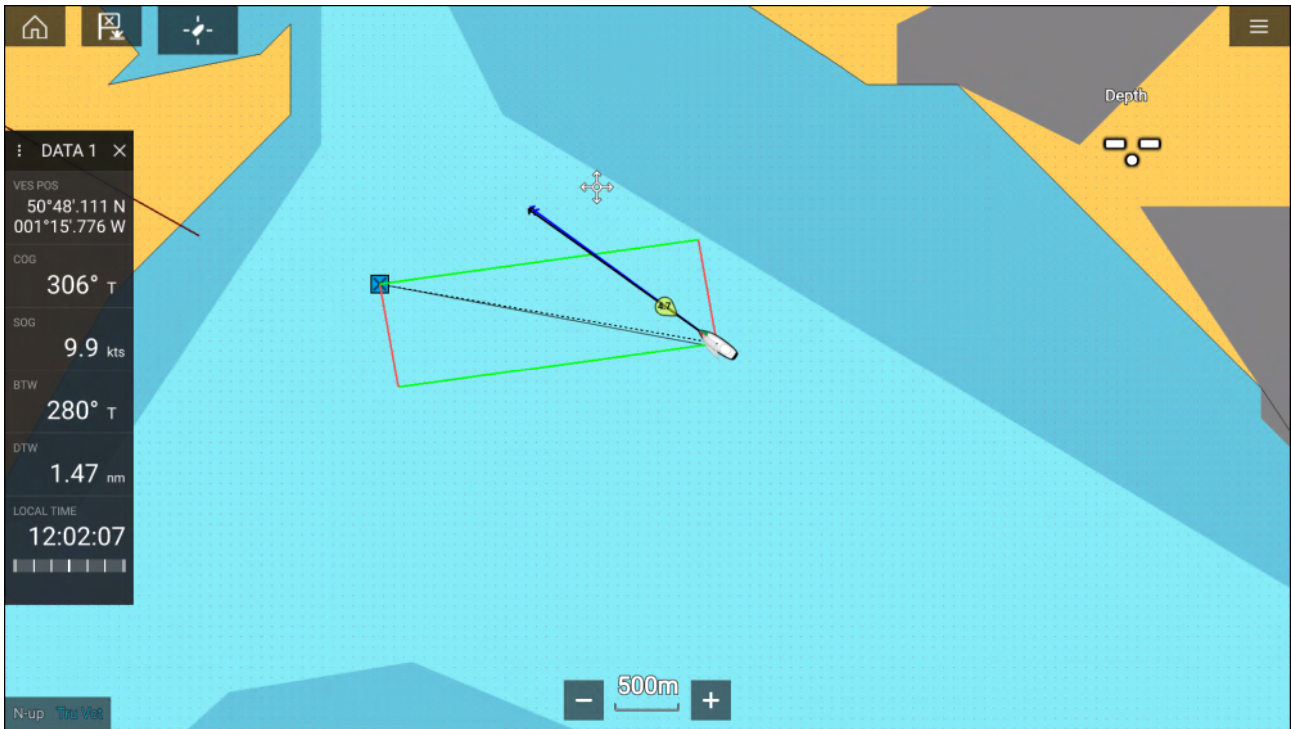

Note:

You should not steer your vessel so that its heading points exactly along the layline. Instead try to align your Course Over Ground (COG) with the visual laylines, as well as using the information displayed on the Sailing page in the **Dashboard app** to help you steer to your optimum wind angle. Your vessel should then travel along the layline, under the effects of tide and leeway.

Sailing data page

Sailing data and dials are available for display alongside laylines to help indicate which direction to turn in order to maximise your VMG to windward.



Sailing dials can be displayed in the **Dashboard app** by selecting the Sailing default data page. For more information on customizing the Sailing data page, refer to [Chapter 12 Dashboard app](#)

Laylines — system requirements

To use the Laylines feature, your system must meet the following conditions:

- Your MFD must be running LightHouse™ software version 3.9 or later.
- The **Boating Activity** setting must be set to **Sailing** during the MFD Startup Wizard procedure. For more information on how to configure the **Boating Activity** settings, refer to: [4.5 Getting started](#)
- The following data must be present on the MFD network:
 - Wind
 - Speed Through Water (STW)
 - GPS
 - Heading

Enabling Laylines

The Laylines feature can be enabled from the Laylines settings page in the **Chart app**.

Chart app > Menu > Settings > Laylines

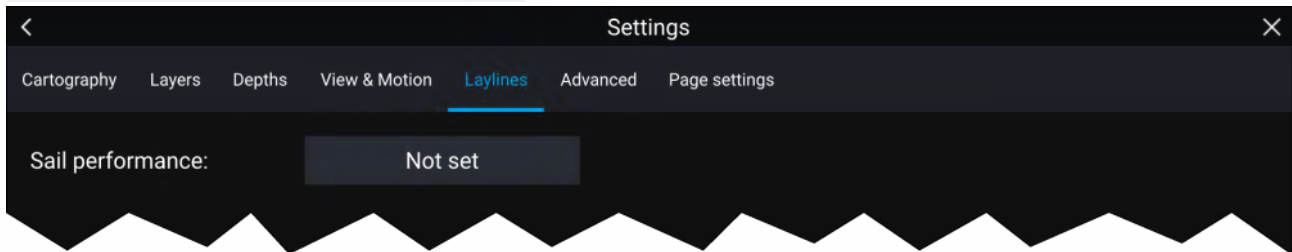

From this page you can select the Layline Sail Performance profile:

- Fixed, or
- Polar

With the relevant Sail Performance profile selected, laylines will be displayed automatically in the Chart app.

Laylines settings

The following settings are available on the laylines page:

Setting	Description	Options
Sail Performance	<p>Allows you to select a profile that determines the preferred level of sailing performance when using laylines. The laylines feature is only available when the profile is set to Fixed Angles or Polars.</p> <ul style="list-style-type: none"> • Not set — laylines are disabled. • Fixed Angles — laylines are created based on specified Upwind and Downwind angles. These angles are set by default to 45° and 140° respectively and can be configured in the menu. • Polars — laylines will be created using a polar table available on your MFD. You can select the relevant polar 	<ul style="list-style-type: none"> • Not set • Fixed • Polar

Setting	Description	Options
	table using the Polar menu item, described below.	
(Fixed angle) Upwind angle	<ul style="list-style-type: none"> Set the upwind angle for layline calculations. 	<ul style="list-style-type: none"> 15° to 70° 45° (default)
(Fixed angle) Downwind angle	<ul style="list-style-type: none"> Set the downwind angle for layline calculations. 	<ul style="list-style-type: none"> 125° to 175° 140° (default)
(Polar) Polar	<ul style="list-style-type: none"> Select the Polar table that will define your layline calculation. Selecting a vessel's make and model that most closely matches your own vessel will provide better calculations and more accurate laylines to follow when sailing. If your vessel's make and model are not listed, submit the polar data for your vessel to: polars@raymarine.com so it can be included in the next software release. 	<ul style="list-style-type: none"> List of available Polar tables
Display Layines on this chart	<ul style="list-style-type: none"> Display or hide laylines on the current Chart app instance. 	<ul style="list-style-type: none"> On Off
Adjust for tides	<ul style="list-style-type: none"> Adjust the laylines to take into account tidal flow. 	<ul style="list-style-type: none"> On Off
Boat type	<ul style="list-style-type: none"> Set your vessel's boat type to provide more accurate leeway calculation. 	<ul style="list-style-type: none"> List of available Boat types
Show wind shifts	<ul style="list-style-type: none"> Display the minimum and maximum waypoint laylines, based on the varying True Wind Direction (TWD) over the last specified period. 	<ul style="list-style-type: none"> On Off
(Wind shifts) Time Period	<ul style="list-style-type: none"> Set the specified time period for wind shifts. 	<ul style="list-style-type: none"> 3 min 6 min (default) 12 min 30 min 60 min
(Wind shifts) Reset	<ul style="list-style-type: none"> Reset the recorded time of historical wind shifts back to 0. 	<ul style="list-style-type: none"> Reset

Displaying and interpreting laylines

Once laylines are enabled and correctly configured in the **Laylines** tab in the Chart app Settings, they will start rendering on the Chart display as your vessel is underway.

Laylines are displayed as a parallelogram under the following conditions:

- The vessel is under active navigation towards a **Waypoint** or **Goto**.
- The tack is required to meet an active **Waypoint** or **Goto**.
- The direct distance to the destination point is less than 150 nm from your vessel.

When the destination point is **upwind** the laylines will be displayed in a parallelogram formation, with green and red laylines showing the port and starboard tacks, as shown below:

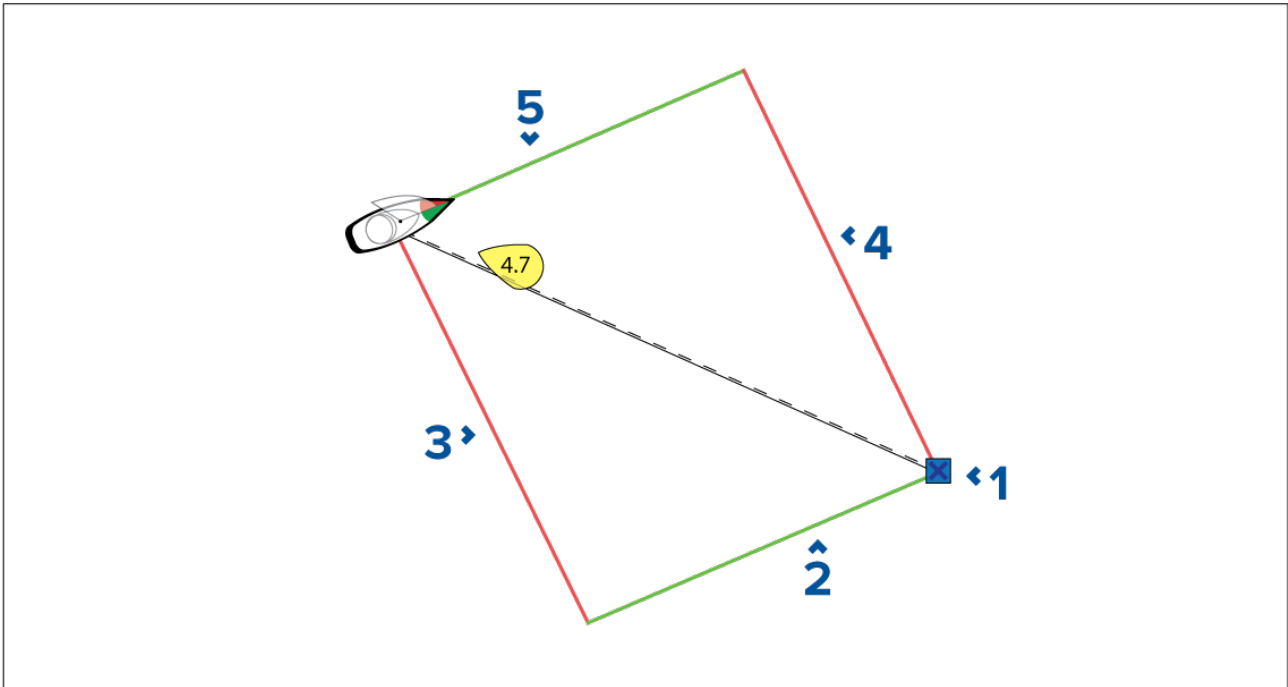

1. Destination
2. Starboard destination layline
3. Port vessel layline
4. Port destination layline
5. Starboard vessel layline

When the destination point is **downwind** the laylines will be displayed as an orange parallelogram formation, adjusted for gybing, as shown below:

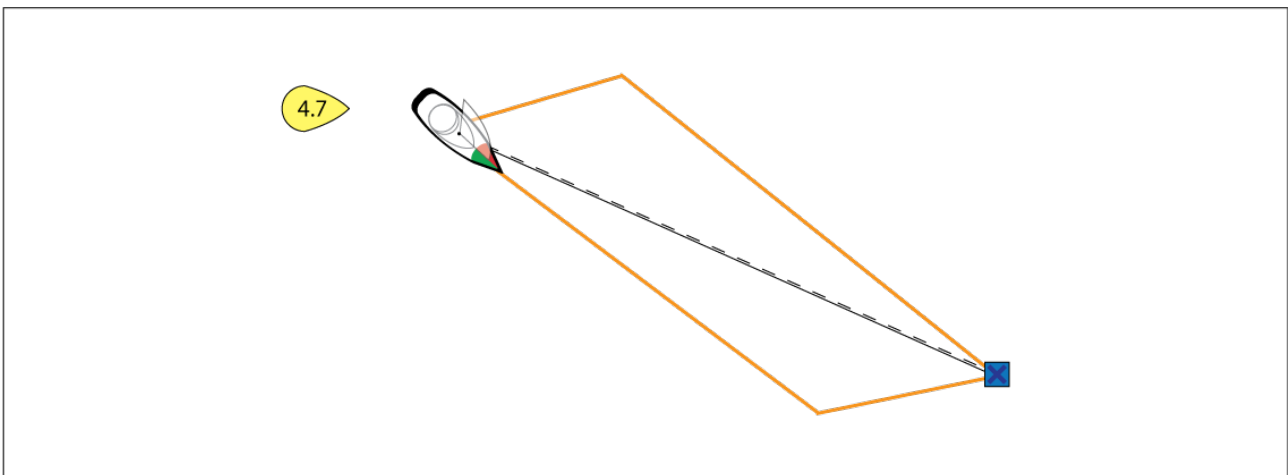

Displaying wind shift data

As True Wind Direction (TWD) is constantly changing, the position of the laylines changes over time. These changes are shown as lighter colored shaded triangles which represent the variation of TWD over a specified time period.

- With TWD holding at the high end of its range of variation, the vessel can tack to starboard and will lay the windward or leeward mark as it enters the shaded area. However, if TWD shifts back towards the lower end of its range of variation, the vessel will fall short of the layline and may have to perform extra tacks to reach the waypoint.
- With TWD holding at the low end of its range of variation, the vessel can tack to starboard and will only lay the windward or leeward mark when it reaches the end of the shaded area. However, if TWD shifts back towards the high end of its range of variation, the vessel will overstand the windward or leeward mark and may need to travel farther to reach the waypoint.

- Depending on the situation, the normal course of action would be to tack when the vessel is halfway through the shaded area. However this may not be the shortest or quickest route.

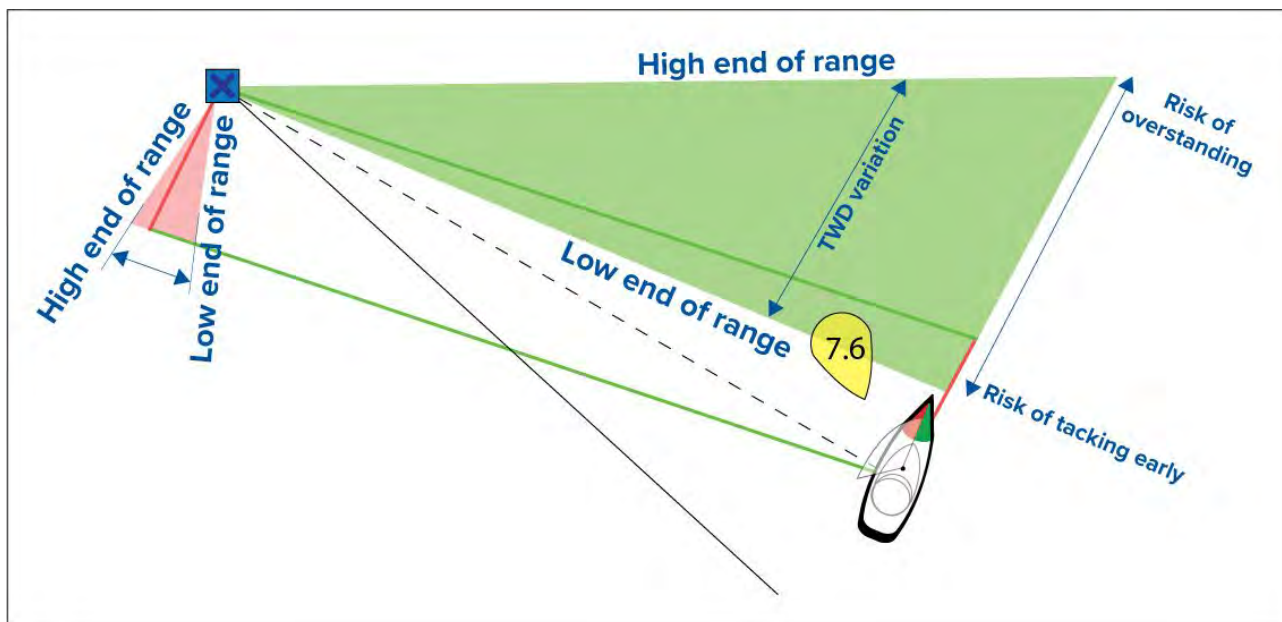

Wind shift data options are available from the **Laylines** settings page:

Chart app > Settings > Laylines



- **Show wind shifts** — Toggle wind shifts ON / OFF
- **Time Period** — Select the time period that you want the wind shift data to cover
- **Reset** — Reset the recorded wind shift data

8.5 Race Start Line (SmartStart) and Race Timer

The Race Start Line and Race Timer features can help you achieve a better racing start. The features assist you in approaching the race start line at the optimum speed, angle and time.

The basic concept of an effective race start is to guide your vessel and tune the sail configuration in an optimum way to ensure you are approaching the start line at the very last moment with full power. In race sailing, the countdown to this last moment is known as “Time to Burn”.

The race start line features help you to do this by providing a visual indication of the position of the race line on the Chart, as well as key data, including race timer, distance to start line, line bias, and Time to Burn. These features can also be used in conjunction with Laylines to further assist you in optimizing your approach to the start line. When the Race Start Line, Race Timer and Laylines are active, Laylines will visually protrude from the race start line’s port and starboard ends to help guide your vessel on an optimum course to the start line.

For more information on Laylines, refer to: [p.122 — Laylines](#)

The Race Start Line and Race Timer data is displayed in 2 different places:

- **In the Chart app’s Sidebar** — When the Chart app is in Racing mode, you can swipe from the left of the screen to display a sidebar showing the key race start information.
- **In the Dashboard app** — The dedicated Race Start page displays key race start information, including an apparent wind sailing dial, race timer, distance to start line, line bias, Time to Burn, and more. For more information, refer to: [p.243 — Race Start data items](#)

Note:

- Lighthouse software version 3.10 or later is required.
- The Race Start Line and Race Timer features require that the Chart app is set to Racing mode, accessible from the Chart app Menu.
- The Race Start Line and Race Timer sync to all MFDs on the network and can be interacted with on all MFDs on the network.
- Race Start Line and Race Timer options are available via the Sidebar when the Chart app is in Race Start mode.



Creating the Race Start Line

A Race Start Line can be created by placing port and starboard end points.

The end points can be created by:

- Placing them anywhere on the Chart app — or for greater accuracy — placing them using existing chart waypoints and chart objects (e.g. Buoys).
- Pinging your vessel's current location, using GPS position data.

Once both end points have been entered, the race start line will be drawn between the two points.

Placing the Race Start Line

Race Start Line end points can be placed anywhere on the Chart app. You can use waypoints or chart objects to place Race Start Line end points at specific coordinates.

To place an end point on a waypoint or chart object:

1. Select the waypoint or chart object to display the context menu.
2. Select **Set start line**.
3. Select **Port end** or **Starboard end**.
4. Repeat for the alternate end.

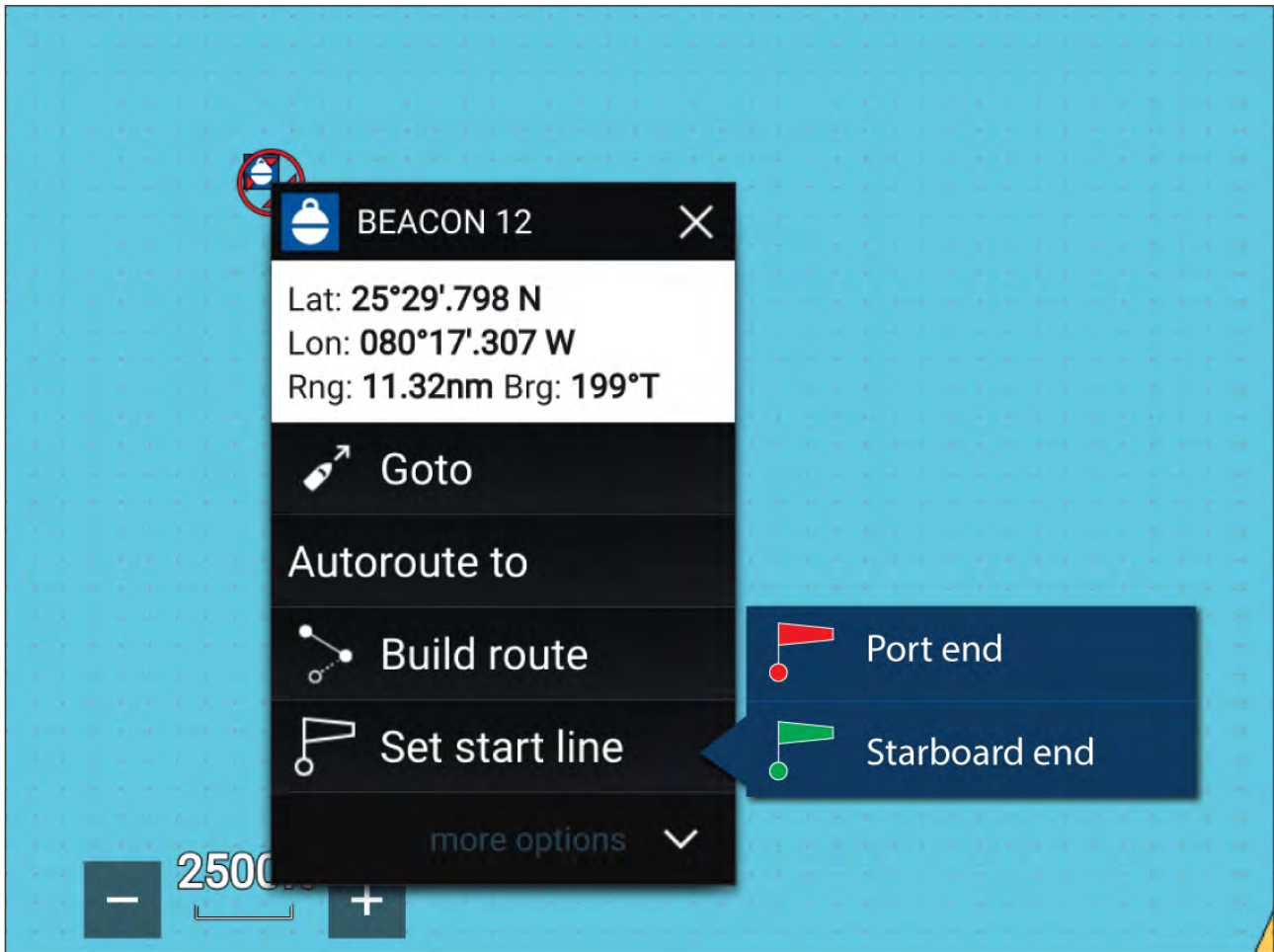

Pinging the Race Start Line

You can use your vessel's location to ping each end of the Race Start Line.

When your vessel is at the end point:

1. Open the menu.
2. Select **Race start line**.
3. Select either **Ping Port end** or **Ping Stbd (Starboard) end**.
4. Repeat for the alternate end.

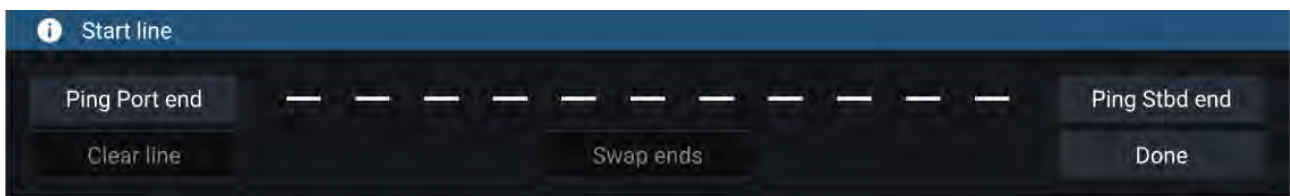

Important:

Pinging the Race Start Line ends will use your GPS location (from an internal or external GPS receiver). When pinging the end points, it is important to compensate for the distance between your vessel's bow and the GPS location.

To increase the accuracy of start line placement:

1. Approach an end point from the same direction you will be traveling when starting the race.
2. Align your vessel so it is perpendicular to the end point.
3. When the bow of your vessel reaches the end point, ping the location.
4. Repeat for the alternate end, ensuring your vessel remains perpendicular to the line.

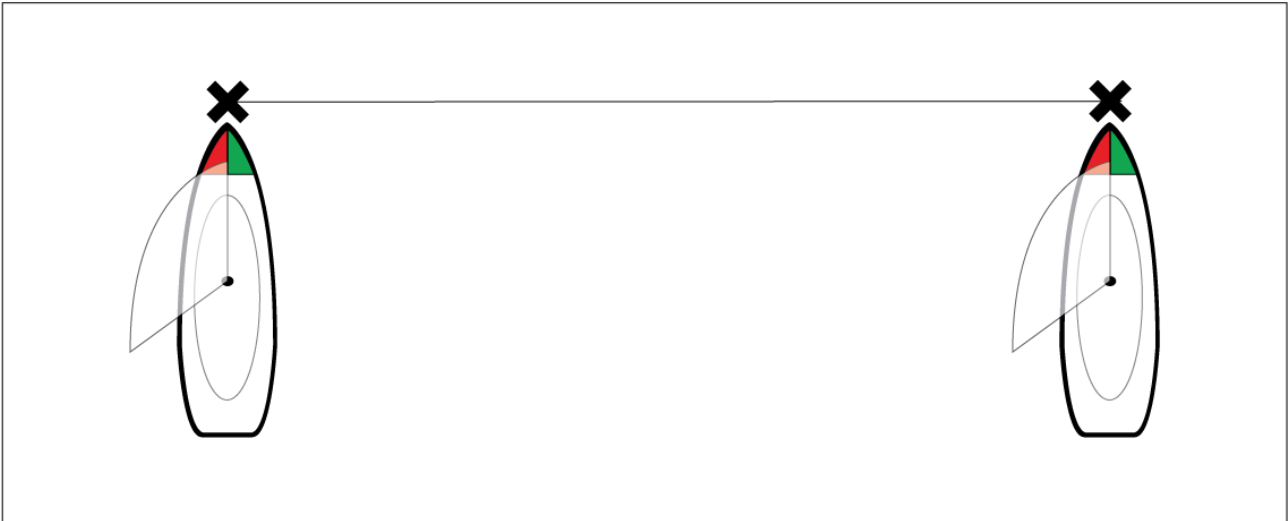

Editing and clearing the Race Start Line

The Race Start Line can be edited and deleted.

To edit the Race Start Line:

1. Select the line or end points on the chart app.
2. Select **Edit line**.

From here you can choose to swap the positions of the Port and Starboard end points, re-ping them to your vessel's current position, or clear the start line.

3. Select **Done** to save changes.

Starting the Race Timer

A Race Timer is available to count down until race start.

To start the Race Timer:

1. Open the menu.
2. Select **Race Timer**.
3. Select **Timer duration** to set the countdown time (default is 5 minutes).
4. Select **Start** to begin the countdown.

Important: The Race Timer can be set from 1 minute to 30 minutes.

5. You can change the countdown time as well as stop and reset the timer by reopening the Race Timer options menu.

Note:
The Race Timer can also be operated from the Dashboard app Race Start Page.

Race laylines

When the Race Start Line, Race Timer and Laylines are active, laylines will protrude from the race start line's port and starboard ends to help guide your vessel on an optimum course to the start line. A Favoured End Marker will also appear on the end point that provides a more competitive start. For more information on laylines refer to [8.4 Laylines](#)

The start line will appear differently depending on whether it is an upwind or downwind start:

- Upwind starts will show red and green laylines as well as a Favoured End Marker on the end point closer to the True Wind Direction (TWD).
- Downwind starts will show orange laylines as well as a Favoured End Marker on the end point farther from the True Wind Direction (TWD).

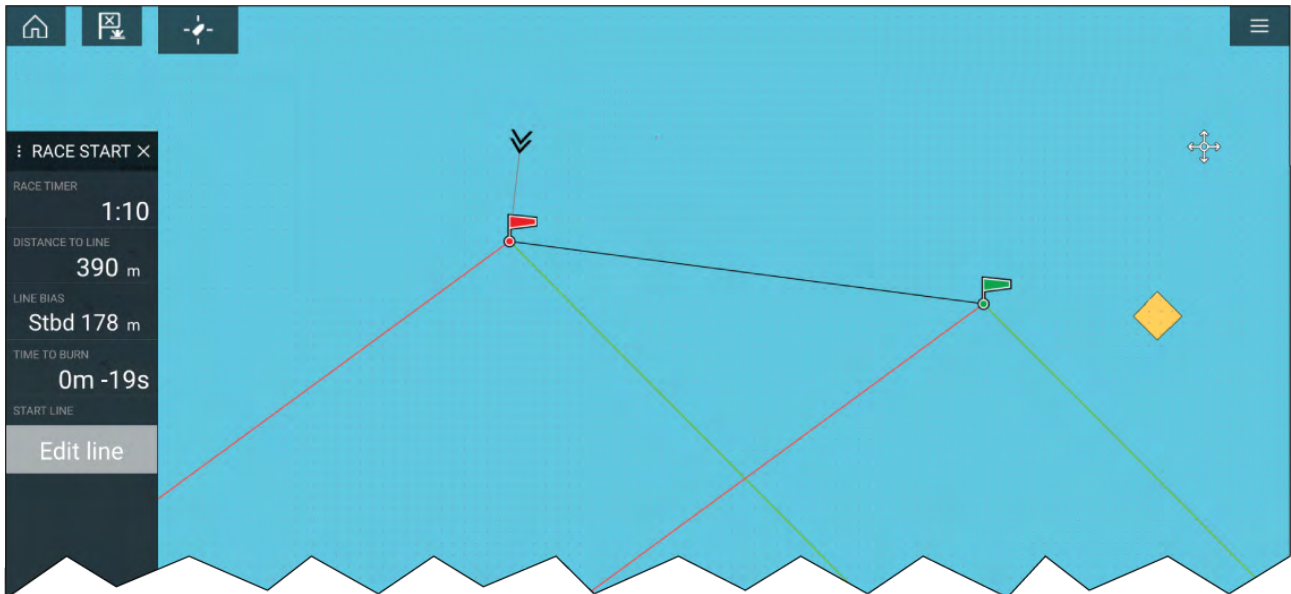

Race sidebar

Race Start Line and Race Timer information and options are available via the Sidebar when it is set to Race Start mode.

Menu item	Description	Options
Race Timer	Displays the countdown time until race start. When the timer reaches 0 it will begin to count up, indicating how long it has been since race start.	Before Start <ul style="list-style-type: none"> Start Timer duration During Countdown <ul style="list-style-type: none"> Sync nearest minute Up 1 minute Down 1 minute Stop & reset When Counting Up <ul style="list-style-type: none"> Stop & reset
Distance To Line	Displays how far your vessel is from any point of the start line.	N/A
Line Bias	Displays how much closer or further away the favoured endpoint is to the wind in comparison to the other endpoint.	N/A
Time To Burn	Displays how much time you have before you need to navigate towards the start line. A negative value is shown if you are predicted to be running behind and will not be at the start line at race start. Time to burn is calculated using wind speed and speed through water (STW): <ul style="list-style-type: none"> If you are using polars for sail performance then speed from the polar diagram is 	N/A

Menu item	Description	Options
	<p>used as the assumed starting speed through water.</p> <ul style="list-style-type: none"> If you are using fixed angles or have nothing set then you can manually set the expected speed or use your current speed by opening the race start line context menu (long pressing the start line). <p>For more information on sail performance refer to Laylines settings</p>	
Edit Line	<p>Allows you to edit the end points of the start line or clear it. You can ping the port or starboard end points to your current location as well as swap them.</p>	<ul style="list-style-type: none"> Ping Port end Ping Stbd (starboard) end Swap ends Clear Done

Dashboard

New race start data items are available in the dashboard app. These can be customized and displayed alongside the Race Start Line and Race Timer features. For more information refer to [Race Start data items](#)

8.6 Target tracking

With compatible AIS and Radar hardware connected to your MFD, AIS and Radar targets can be tracked in the Chart and Radar apps.

When targets are being tracked they appear in the AIS or Radar targets list.

The target lists can be accessed by selecting **Targets** from the app menu: **Menu > Targets** , and then selecting the relevant tab.

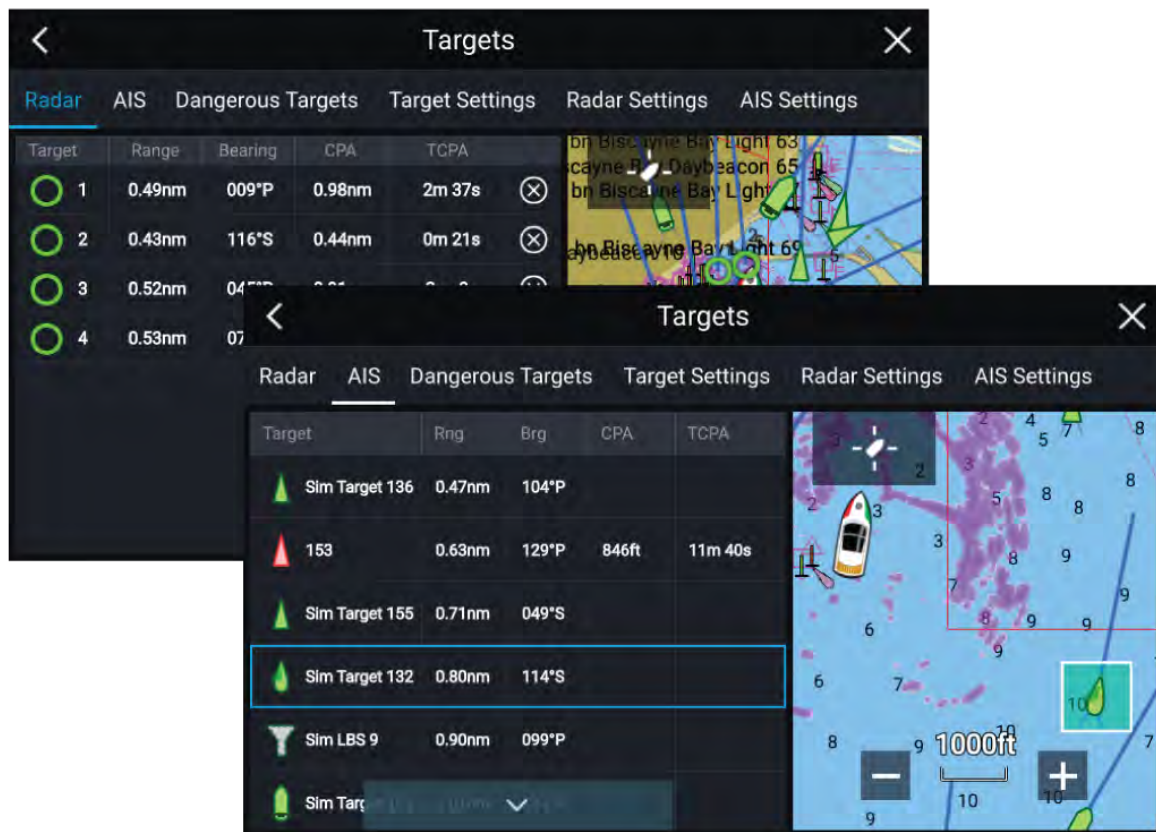

Selecting a target from the list highlights the selected target in the **LiveView** app pane on the right of the page.

The list identifies: Target name, Range from your vessel, and Bearing. Where relevant, CPA (Closest point of approach) and TCPA (Time to Closest Point of Approach) values will also be displayed.

AIS list

The AIS target list displays pop-over options which enable you to **View full target data** or add a target as an AIS buddy by selecting **Add as buddy**.

The Buddy feature enables you to add AIS-equipped friends and regular contacts to a “Buddy List” on your MFD. As soon as a vessel on your Buddy List comes within range of your AIS receiver, the onscreen vessel icon changes to indicate this.

AIS icons used for targets marked as buddies will be filled yellow. You can also rename buddy targets or remove targets from your buddy list.

Radar list

The Radar target list can be **Sorted By:** target **Number** or its **Range** from your vessel.

Radar targets can be cancelled individually by selecting the ‘X’ next to the target’s details in the list, or you can cancel all targets by selecting **Cancel all targets**.

You can display Radar target information onscreen by selecting **Target info** from the Radar target pop-over options.

Target vectors

Vector graphics can be displayed for AIS targets.

Target vectors settings can be accessed from the **Target Settings** tab: **Menu > Targets > Target settings**.

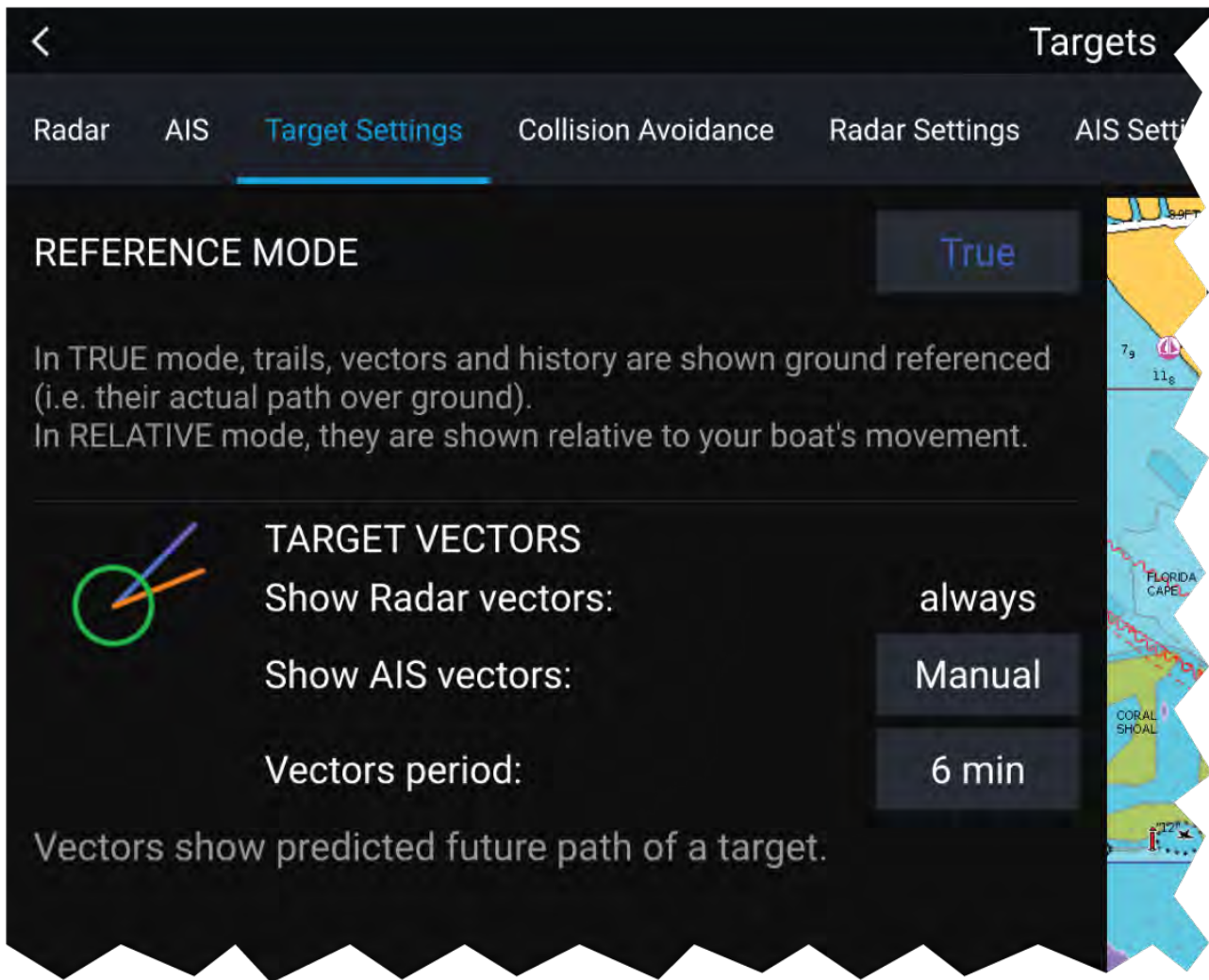

The vectors can be set to **True** or **Relative**.

The Vector length identifies where the target will be after the specified time has passed. You can adjust the length of the vector by selecting a time from the **Vector length** pop-over options.

AIS vectors can be set to **All** (displayed for all targets) or **Manual** (only displayed when enabled using the target's context menu).

Target vectors can be enabled and disabled for individual targets: Press and hold on an AIS target to display the context menu, and then select **Vector**.

Dangerous targets alarm

You can use the Dangerous targets alarm to notify you if a target will reach a specified distance from your vessel within a specified time.

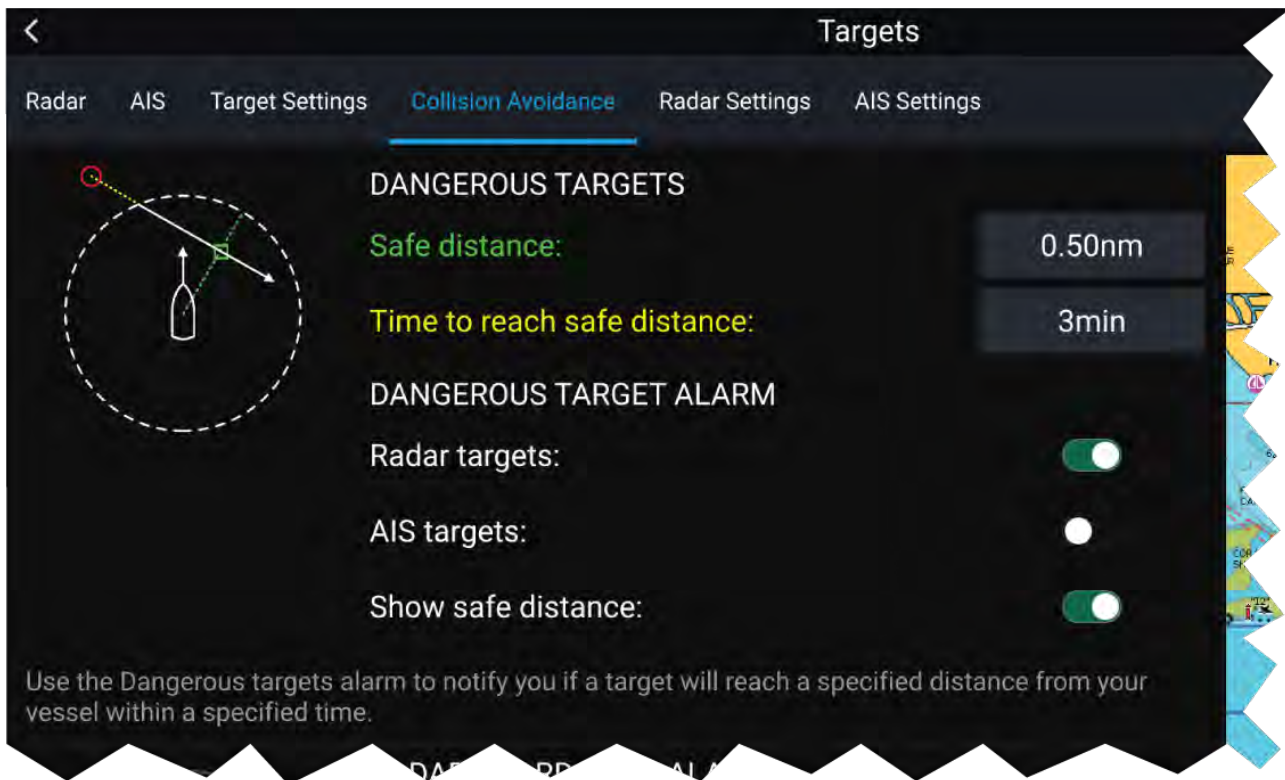

To set up the Dangerous target alarm, first adjust the **Safe distance** to the desired value and then select a **Time to reach safe distance**. The alarm will be triggered if a tracked target will reach the specified Safe distance from your vessel within the time period selected.

You can select whether you want the Dangerous target alarm to track **Radar targets**, **AIS targets** or both.

You can display a Safe distance ring around your vessel in the Chart and Radar app using the **Show safe distance** control.

Radar settings

When the Radar layer is enabled in the Chart app you can configure the **Radar settings** from the **Targets** menu: **Menu > Targets > Radar settings**.

Setting	Description	Options
Radar selection	When more than 1 Radar scanner is connected you can choose which Radar to use for the Radar layer in the Chart app.	List of available Radar scanners
Transmit	Start the Radar scanner transmitting or put it in Standby.	<ul style="list-style-type: none"> • On • Off
Dual range	Enables and disables dual range on compatible Radar scanners	<ul style="list-style-type: none"> • On • Off
Channel	When Dual range is active, you can switch between channels.	<ul style="list-style-type: none"> • 1 • 2
Show Radar overlay	Enables and disables the Radar layer in the Chart app.	<ul style="list-style-type: none"> • On • Off
Visibility	Determines the visibility (opacity) of the Radar layer.	<ul style="list-style-type: none"> • 0% to 100%

Setting	Description	Options
Palette	Selects the color used for the Radar layer	<ul style="list-style-type: none"> • Purple • Black • Red
Show sector blanking limits	Enables and disables radar blank sectors. For more information on blank sectors refer to 11.12 Blank sectors	<ul style="list-style-type: none"> • On • Off
Use Radar without heading data	Enables use of Radar layer when Heading data is not available.	<ul style="list-style-type: none"> • On • Off
Range	Determines the range used for the Radar layer.	Radar range values

AIS settings

When the AIS layer is enabled in the Chart app you can configure **AIS settings** from the **Targets** menu: **Menu > Targets > AIS settings**.









Setting	Description	Options
Show AIS targets in Chart / Show AIS targets in Radar	Enables and disables AIS targets in the Chart and Radar apps.	<ul style="list-style-type: none"> • On • Off
Enhanced AIS targets	Enables and disables the display of enhanced AIS target icons.	<ul style="list-style-type: none"> • On • Off
Show these AIS types	Determines the types of AIS target displayed in the Chart and Radar apps.	<ul style="list-style-type: none"> • All • Dangerous • Buddies
Hide static targets	When enabled, an AIS target travelling under 2 knots will be hidden, unless it is or becomes dangerous.	<ul style="list-style-type: none"> • On • Off
Silent mode	When enabled, your vessel's AIS device will not transmit your position or details.	<ul style="list-style-type: none"> • On • Off

AIS target symbols

By default, standard AIS symbols are used to identify AIS targets.

You can enable enhanced AIS target symbols from the **Advanced Settings** menu: **(Menu > Settings > Advanced > Enhanced AIS targets)**. With enhanced mode enabled, the enhanced symbols are used in place of the standard vessel symbols.

Standard AIS symbols — type

	Vessel		SART (Search and Rescue Transponder)
	Land-based station		ATON
	SAR (Search and Rescue)		Virtual ATON
	* Blue Force vessel		* Blue Force SAR







Note: * Requires STEDS-AIS hardware.

Vessels equipped with STEDS-AIS hardware appear as Blue Force targets if:

- your MFD has a valid passphrase.
- you have received a SITREP from them within the last 6 minutes.
- their AIS mode is not set to Receive only.

If the above conditions are not met then the target icon will revert to using the standard, Green AIS target icon.





Enhanced AIS symbols – type

	Sailing Vessel		Commercial
	High speed vessel / Wing In Ground vessel		Cargo vessel
	Passenger vessel		Other

Enhanced AIS symbols are scaled or outlined according to the reported size of the vessel, as shown below:

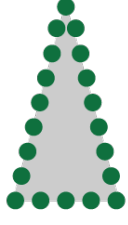
	Relative length (Grey outline)		
---	--------------------------------	--	--

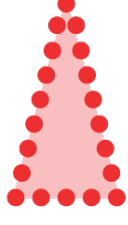
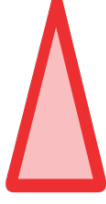
AIS symbol status

	Lost (No border, crossed through)		Uncertain (Dashed outline)
	Buddy (Yellow fill)		Dangerous and Uncertain (Dashed outline and Flashes Red)
	Dangerous (Flashes Red)		ATON off position (Red border)

Blue Force overview

Blue Force allows suitably-equipped vessels and AIS base stations to transmit and receive secure messages with each other.

The Blue Force features offer secure (encrypted) communications and surveillance capability through the existing Automatic Identification System (AIS) network.

As these messages cannot be received by standard AIS receivers, Blue Force-equipped vessels are effectively invisible to non-Blue Force users, in terms of AIS transmissions. Blue Force users can still receive the standard AIS transmissions of other non-Blue Force vessels.

Unique AIS target icons are used onscreen to represent Blue Force participants.

Note:

- Blue Force features require an AIS5000 unit connected to your MFD network.
- Blue Force features require LightHouse 3 version 3.10 or later.

Blue Force SITREP

If your MFD is networked to an AIS5000 and you have entered your passphrase, you can update your Situation Report (SITREP) status as well as view other Blue Force vessels equipped with STEDS-AIS hardware and see their SITREP status.

Note:

- Requires Lighthouses software version 3.10 or later.
- For more information about Blue Force features, refer to: [p.139 – Blue Force overview](#)
- For more information on how to setup blue force features refer to [p.84 – Responder setup](#)

Once responder information has been entered, other Blue Force vessels equipped with STEDS-AIS hardware using the same passphrase will display on the Chart app. Opening a Blue Force vessel's AIS context menu will display their vessel type and SITREP status.

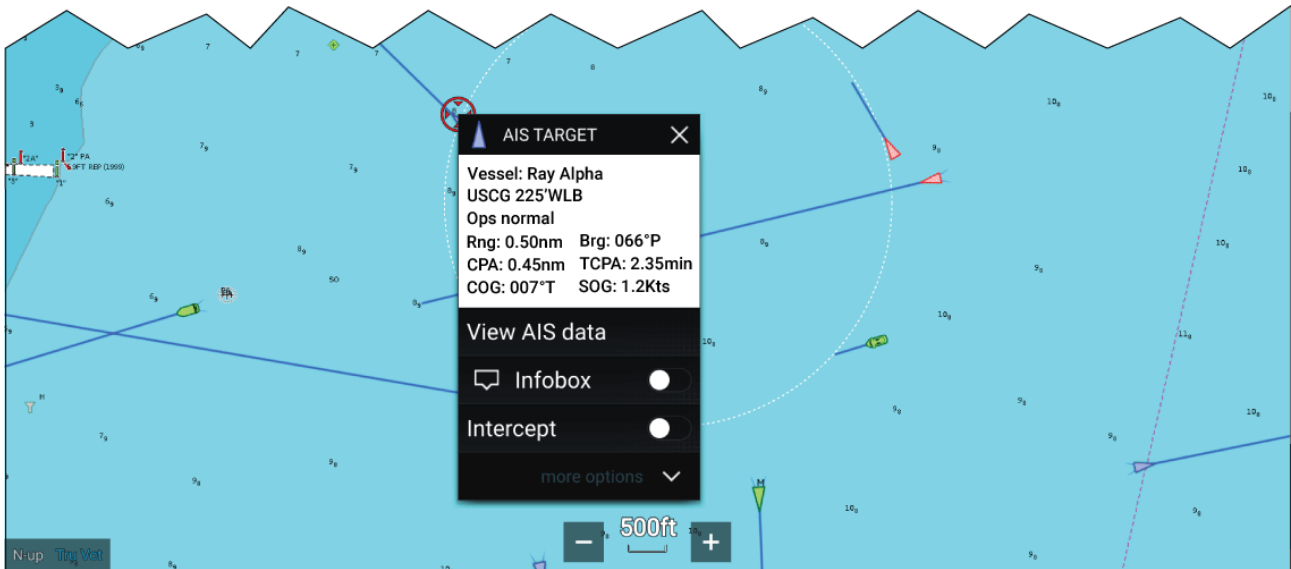

You can set your SITREP status from the Homescreen, by touching the Status Area in the top right of the Homescreen.

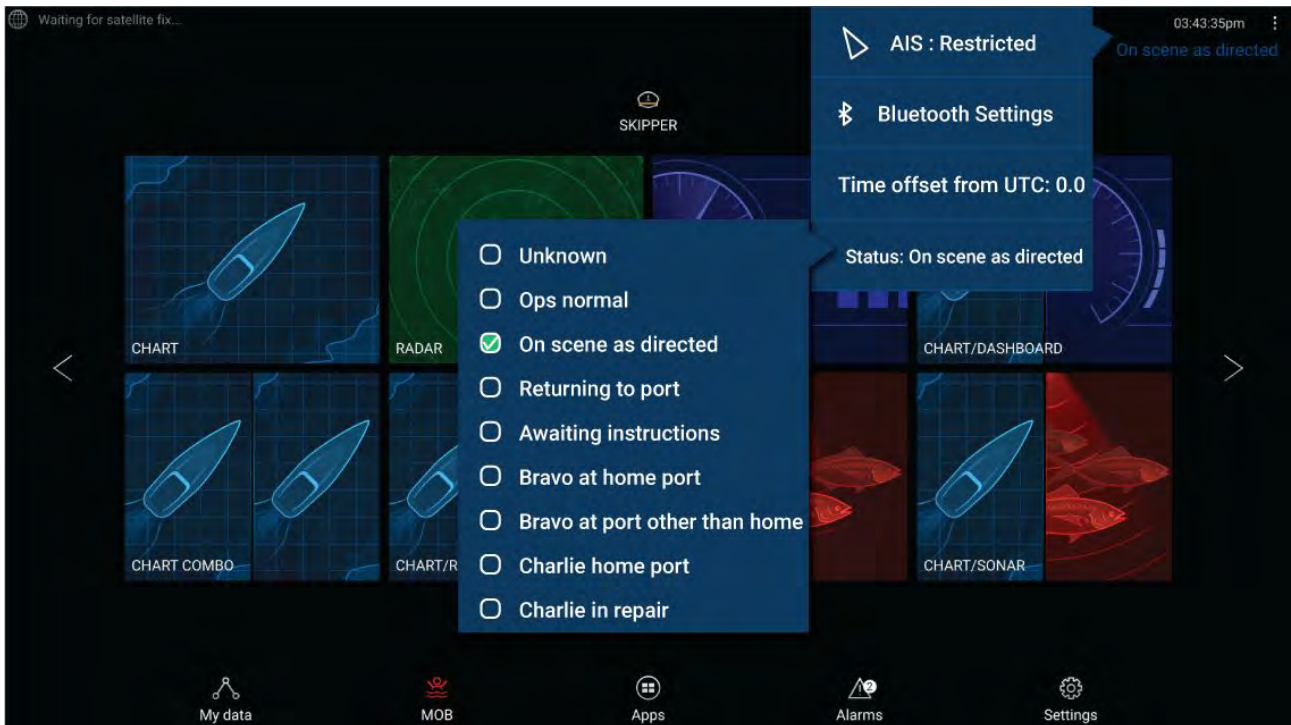

Note:

- SITREP status will update every 15 seconds if a vessel is traveling at 3 knots or more.
- SITREP status will update every 30 seconds if a vessel is traveling under 3 knots for more than 3 minutes.

8.7 Collision avoidance

The **Collision Avoidance** feature tracks AIS targets in relation to your own vessel's Course Over Ground (COG) and Speed Over Ground (SOG). An **Interception line** is displayed from your vessel and the target if your paths are projected to cross.

Additionally, **Predicted Area of Danger** zones are displayed to indicate where there is an increased risk of collision. The **Warning line** and **Predicted Area of Danger** zones are based on your current speed and AIS data received from targets and can help you determine whether you should change course and / or speed to avoid danger.

The **Collision Avoidance** graphics automatically refresh when the MFD receives new position data from the target.

Important: The Collision Avoidance feature is a graphical aid only, provided to help increase user awareness of the potential for collision. It is vital to have a good understanding of the *International Regulations for Preventing Collisions at Sea* (IRPCS / COLREGS), to ensure all actions taken are in accordance with the IRPCS. Important concepts to understand in relation to Collision Avoidance include (but are not limited to): Risk assessment; Right of Way; Restricted visibility; interpreting lights and shapes; interpreting sound and light signals. In the event of conflict, the IRPCS regulations must take precedence. For more information on IRPCS / COLREGS, refer to: [IRPCS](#)



Moving Target

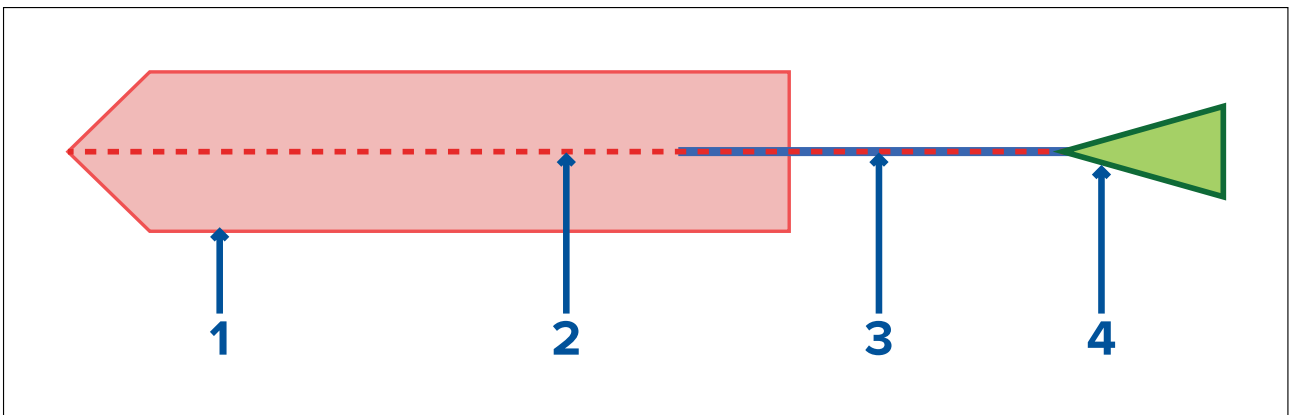

1. Predicted Area of Danger zone (Predicted area based on target's last reported position)
2. Warning line
3. Target COG line
4. AIS Target (Last received position)

Stationary Target

(Target moving less than 2 kts)

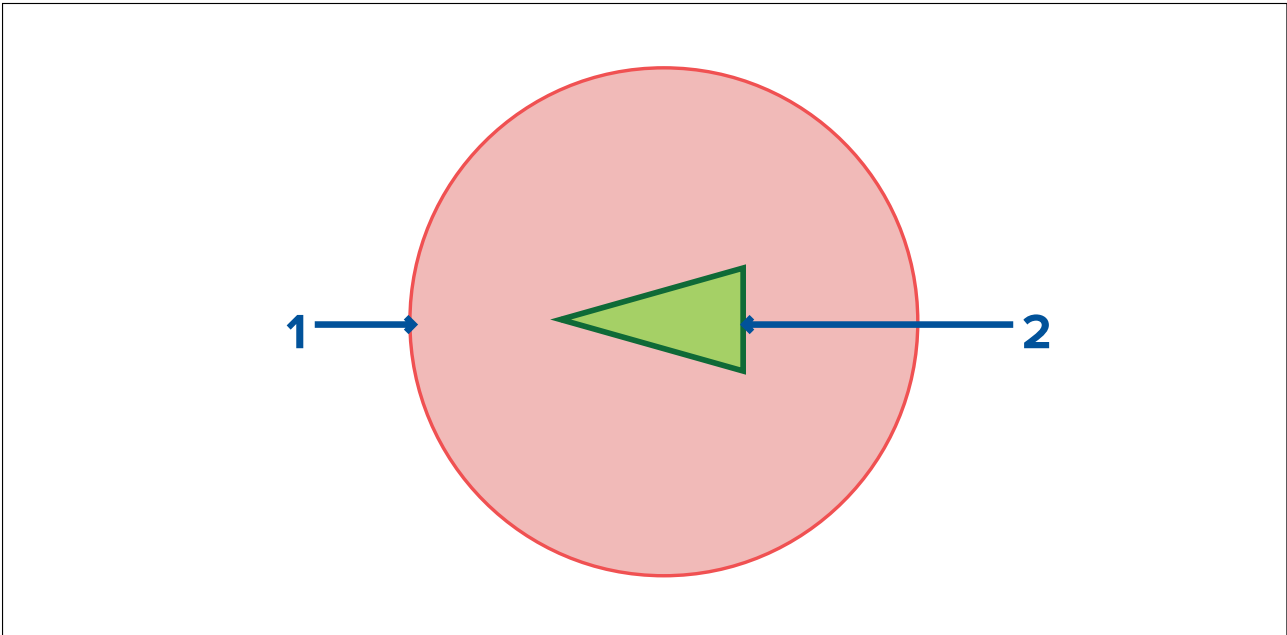

1. Predicted Area of Danger zone (Predicted area based on target's last reported position)
2. Stationary AIS Target (Last received position)

Important: You must still maintain a permanent watch for:

- Vessels that are not equipped with AIS or AIS-equipped vessels that are not currently transmitting their position, as these targets will not be displayed in the Chart application.
- AIS-equipped vessels reporting an inaccurate GPS position, your own vessel's GPS accuracy, or AIS targets with delayed location updates. These situations will cause your vessel's position and / or AIS target positions to be displayed inaccurately in the Chart application.
- Obstructions not equipped with AIS transmitters.

Enabling collision avoidance

The **Collision Avoidance** feature can be enabled in the Chart app.

Chart app > Menu > Targets > Collision Avoidance

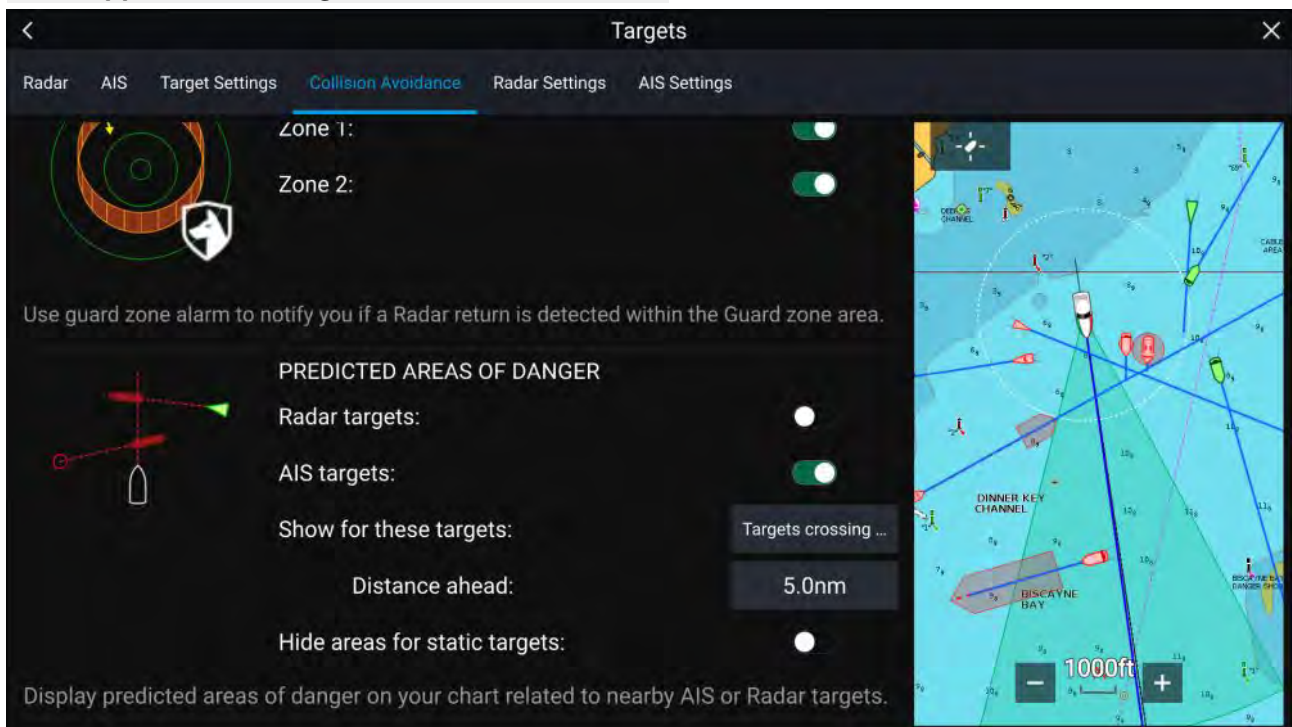

In the **Collision Avoidance** menu you can change the settings to determine which types of target (e.g. AIS or Radar) will have a **Predicted Area of Danger** zone:

Setting	Description
Radar Targets	Enable / disable — Radar targets will have a Predicted Area of Danger zone.
AIS Targets	Enable/disable — AIS targets will have a Predicted Area of Danger zone.
All targets	Displays a Predicted Area of Danger zone on all targets in your vessel's vicinity.
Targets crossing my course	Displays a Predicted Area of Danger zone only on targets which will potentially cross your vessel's Interception line .
Distance ahead	Change the maximum distance of the Interception line in front of your vessel (only available with Targets crossing my course enabled). <ul style="list-style-type: none"> • Minimum: 0.5 nm • Maximum: 5.0 nm
Hide areas for static targets	Enable/disable — Static targets (targets travelling less than 2.0 kts) will NOT have a Predicted Area of Danger zone.

Collision scenarios

There are 3 potential scenarios the **Collision Avoidance** feature can warn you of:

- Own vessel moving faster than target
- Target moving faster than own vessel
- Both targets moving at similar speed

Example scenario 1 — Own vessel moving faster than target vessel

Note: These scenarios are examples provided for guidance only.

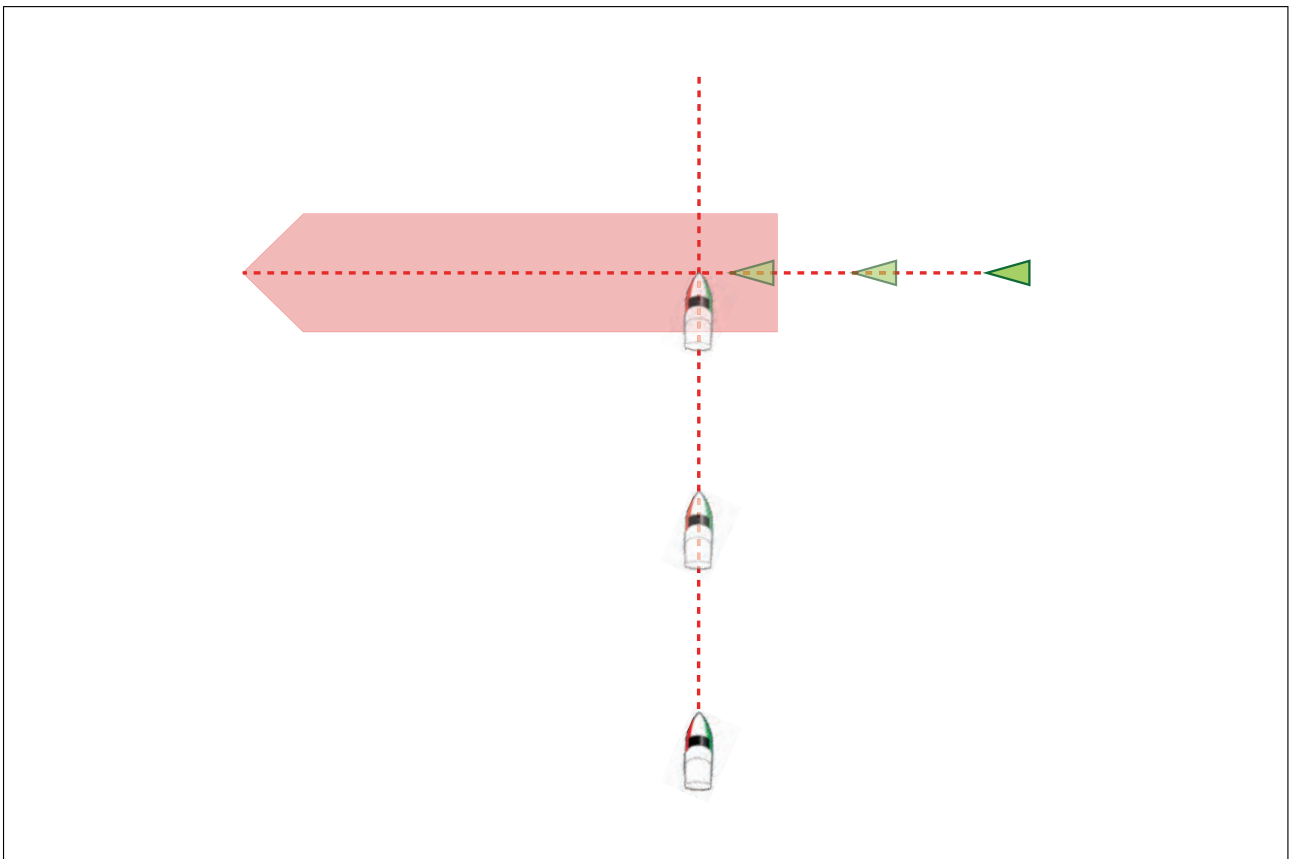

In the example above the vessel's COG will cross with the target's COG within the Interception zone, which could cause a collision. You should alter course and / or speed to avoid the potential collision.

Scenario 1 Course change examples

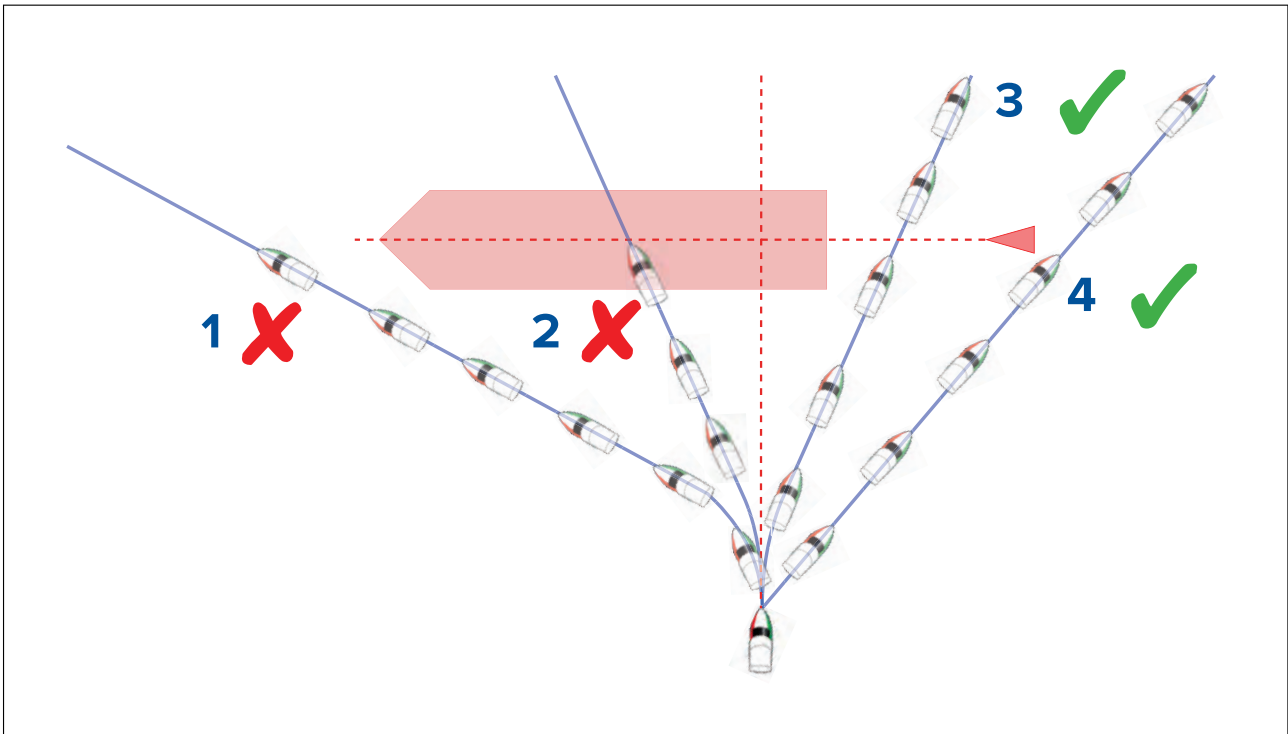

1. Course alteration to pass ahead of the Interception zone **[Not recommended]** — **Proceed with caution**, there is always an inherent risk when passing in front of other vessels.
2. Course alteration to pass ahead of the target vessel **[Not recommended]** — This manoeuvre is not recommended as your vessel will still cross through the target's Interception zone.
3. Course alteration to pass astern of the target vessel and its Interception zone — This manoeuvre alters your vessel's course so that it does not come into contact with the target's Interception zone and passes astern of the target.
4. Course alteration to pass clear astern of the target vessel and its Interception zone. This is the preferred manoeuvre as it correctly alters your vessel's course so that it is clear of the target's Interception zone and passes safely astern of the target. This manoeuvre also clearly indicates to the target vessel your actual change of course.

Figure 2. Scenario 1 Speed change examples

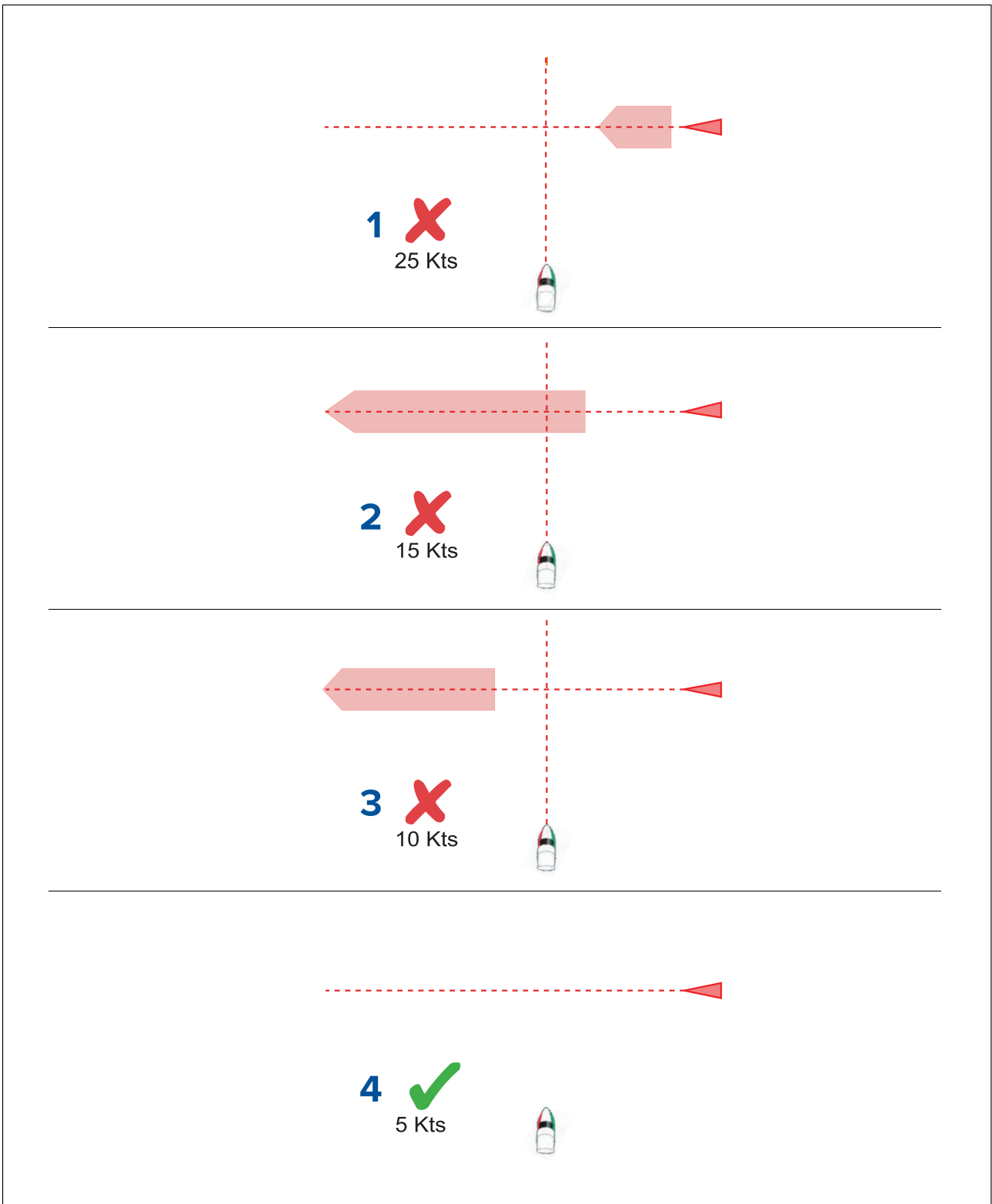

1. ⁽¹⁾**Speeding up [Not recommended]** — Increasing vessel speed to pass ahead of the target vessel. **Proceed with caution**, there is always an inherent risk when passing in front of other vessels.
2. **No speed change [Not recommended]** — Not changing speed or course is not an option as it can result in a collision.
3. **Slowing down [Not recommended]** — Slowing down a sufficient amount will allow the target vessel to pass ahead of your vessel.
4. ⁽²⁾**Slowing down** — Slowing down more than a sufficient amount will allow the target vessel to pass safely ahead of your vessel.

Note:

- ⁽¹⁾ In this example the paths will still cross within the **Intercept distance**, so the graphics are still displayed.
- ⁽²⁾ In this example the paths will no longer cross within the **Intercept distance**, so the graphics are not displayed.

Example scenario 2 – Target vessel moving faster than your vessel

Note: These scenarios are examples provided for guidance only.

In certain situations, when the target vessel is travelling faster than your vessel, there may be more than one opportunity for your paths to cross within the **Intercept distance**. If this is the case then a second Interception zone is displayed.

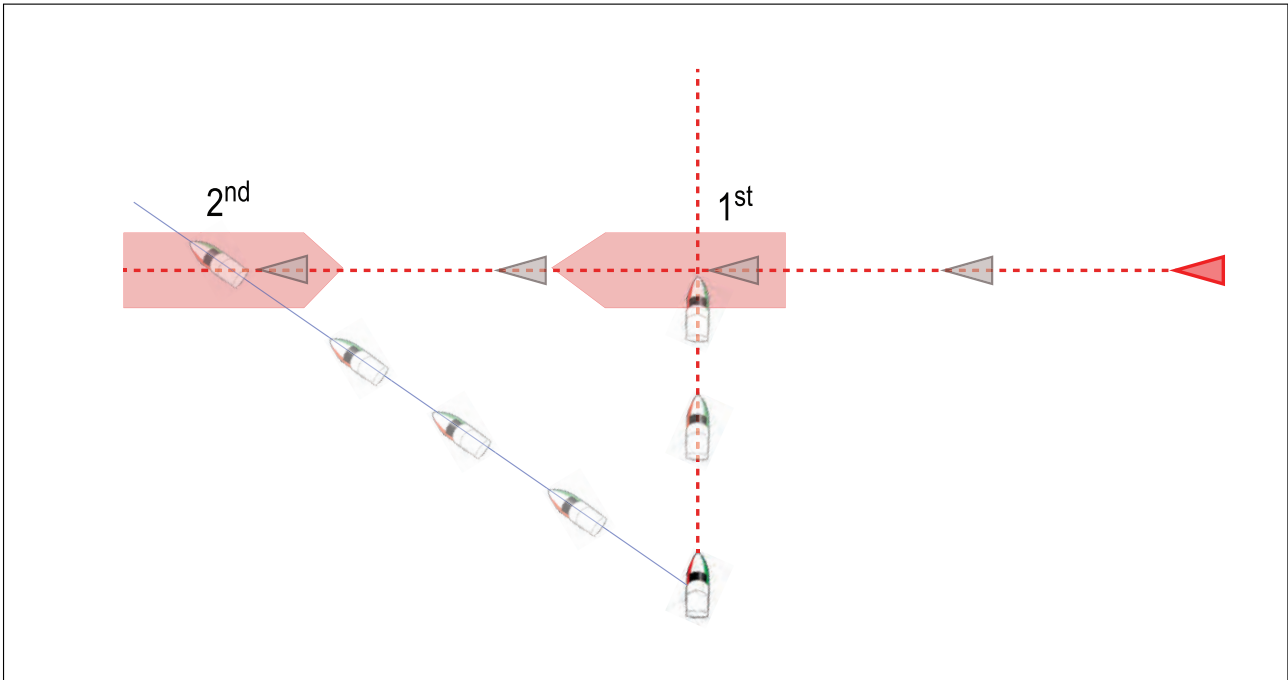

1. 1st — The first Interception zone (displayed closest to the target vessel) represents a bow-to-bow collision.
2. 2nd — The second Interception zone (displayed farthest from the target vessel) represents the target vessel running you down from behind.

When altering course and speed, both Interception zones must be avoided.

Scenario 2 Course change examples

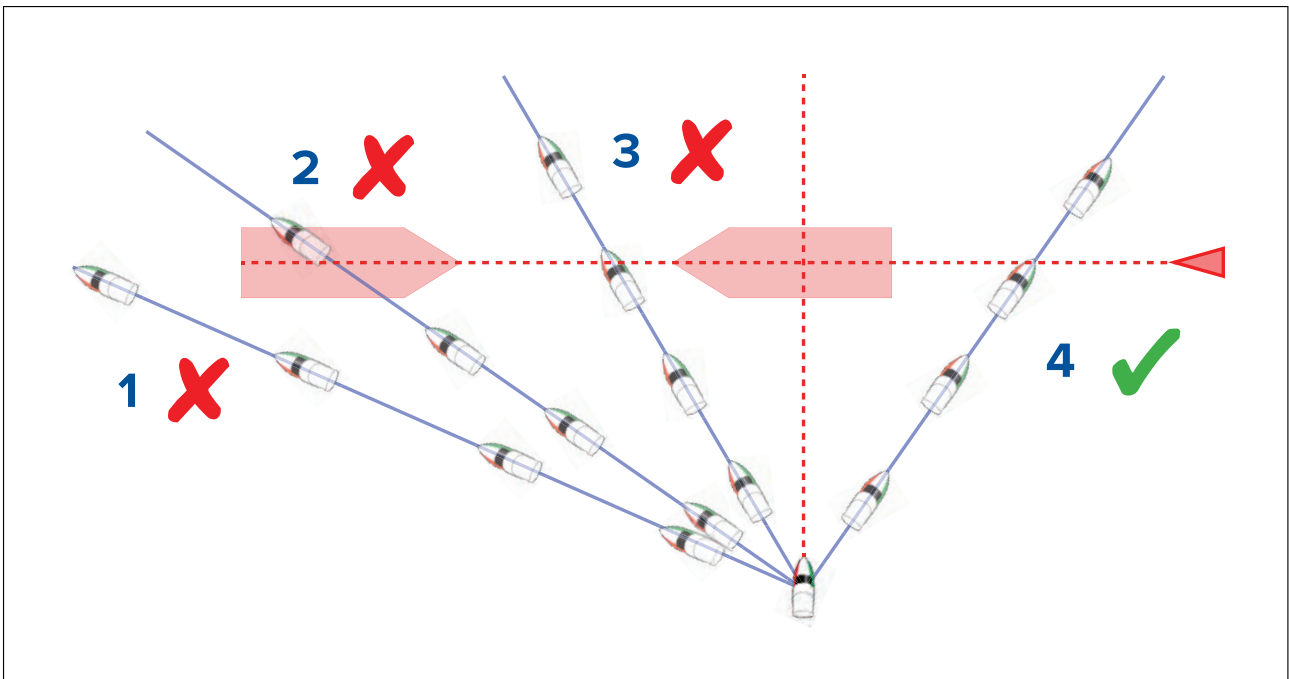

1. Course alteration to pass ahead of the Interception zone **[Not recommended]** — As the target vessel is moving faster than your vessel you will pass astern of the target.
2. Course alteration to pass ahead of the first Interception zone **[Not recommended]** — Although this course alteration is sufficient to avoid a potential bow-to-bow collision, it has created a second Interception zone where the target may now run you down from behind.
3. Course alteration to pass between the 2 Interception zones **[Not recommended]** — Although this may seem like the quickest option, **proceed with caution**, as the gap between the 2 Interception zones can close quickly, especially when your vessel slows down.
4. Course alteration to clear astern of the target vessel and its Interception zone. This would be the preferred manoeuvre as it correctly alters your vessel's course so that it is clear of the target's Interception zone, and passes safely astern of the target. This manoeuvre also clearly indicates to the target vessel your change of course.

Figure 2. Scenario 2 Speed change examples

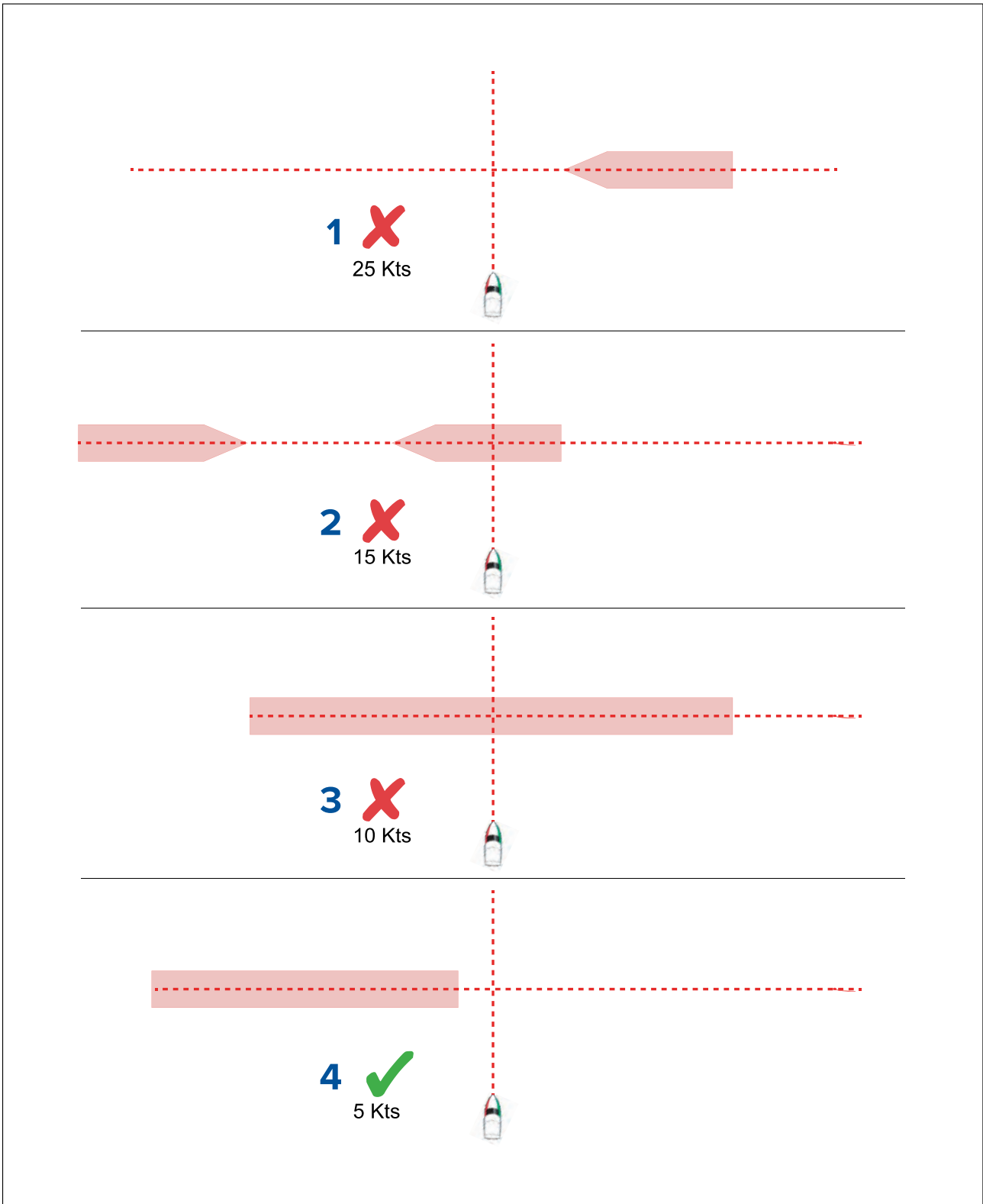

1. **Speeding up [Not recommended]** — Increasing vessel speed to pass ahead of the target vessel. **Proceed with caution**, there is always an inherent risk when passing in front of other vessels.
2. **No change [Not recommended]** — Not changing speed or course may result in a collision.
3. **Slowing down [Not recommended]** — Slowing down slightly may result in the 2 Interception zones closing up or merging into a single zone.
4. **Slowing down** — Slowing down a sufficient amount will allow the target vessel to pass safely ahead of your vessel, avoiding the Interception zone(s).

Example scenario 3 — Both vessels travelling at the same speed

Note: These scenarios are examples provided for guidance only.

Course change

When both vessels are travelling at the same speed, course alterations should be made in accordance with the guidance provided in examples 1 and 2.

Speed change

When both vessels are travelling at the same speed, altering your speed will change the collision scenario to one of the scenarios detailed in examples 1 and 2.

8.8 Target intercept

The **Intercept** feature can be used to help rendezvous with friends or for Pilot boats and the Coastguard to intercept vessels that are to be boarded.

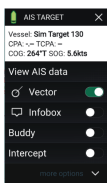

To use the **Intercept** feature, select and hold the target icon until the menu is displayed, then select **Intercept**. The Chart app will automatically plot a direct course to a point where your vessel and the target will cross (intercept). An interception mark is placed at a predicted point where both your vessel and the target will cross.

Important:

When performing an individual interception, you are placing your vessel on a collision course with the target vessel. It WILL be necessary to change to a parallel course to prevent a collision.

Pre-requisites:

- It is vital to have a good understanding of the *International Regulations for Preventing Collisions at Sea* (IRPCS / COLREGS), to ensure all actions taken are in accordance with the IRPCS. For more information on IRPCS / COLREGS, refer to: [IRPCS](#)
- You must be familiar with the AIS feature.
- You must have a thorough understanding of the Target interception feature and its implications before attempting to use it in a real life scenario.

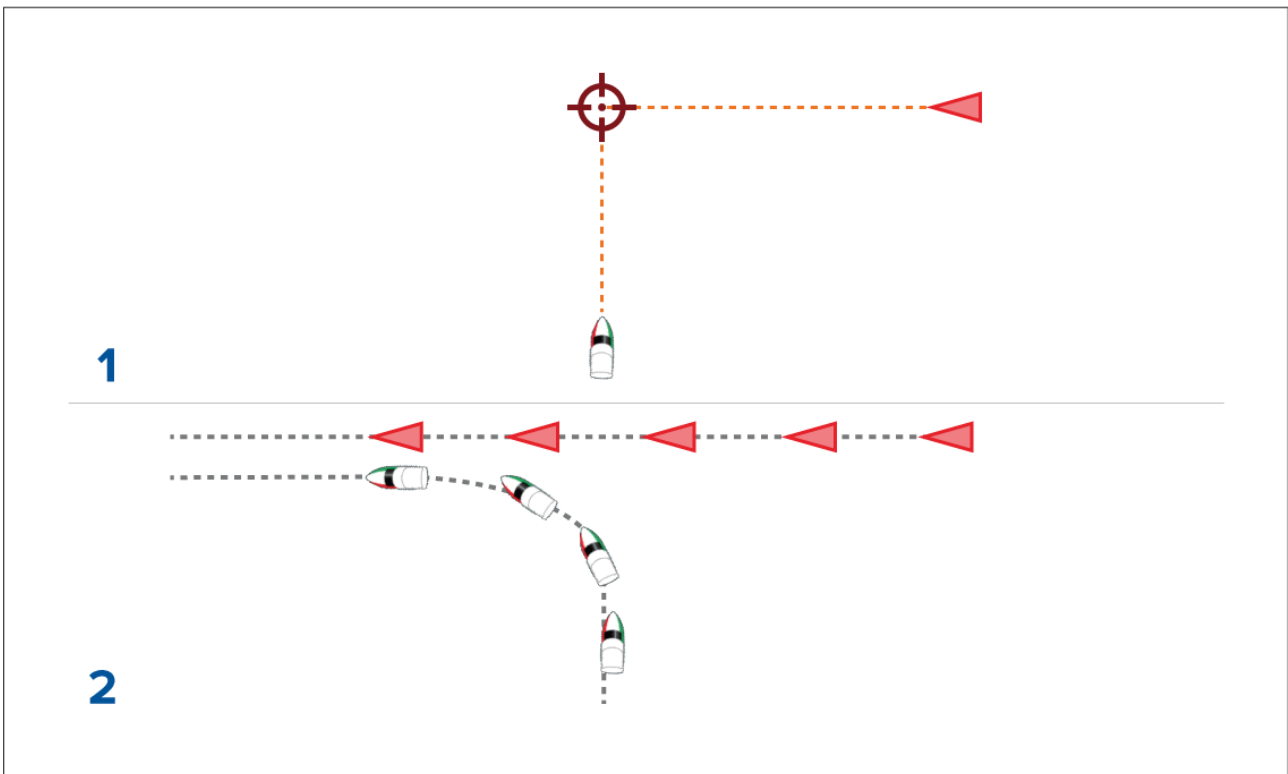

1. Initial Target interception graphics.
2. Actual vessel movements to perform the rendezvous.

8.9 Tides mode

In Tides mode the Tides animation control is displayed onscreen and the Tide station and Current station symbols in the Chart app are replaced with dynamic graphics which identify Tide and Current conditions. You can use the animation controls to play Tide and Current predictions for a 24 hour period. The own vessel Tide vector is also enabled in Tides mode.

Note:

- The Tides mode is only available if you have cartography that provides the Tides and Current data. Refer to your cartography provider for more information.
- The Tides mode requires accurate date information, usually taken from the GNSS (GPS) position data available to your MFD. Alternatively, you can input a specific date manually.

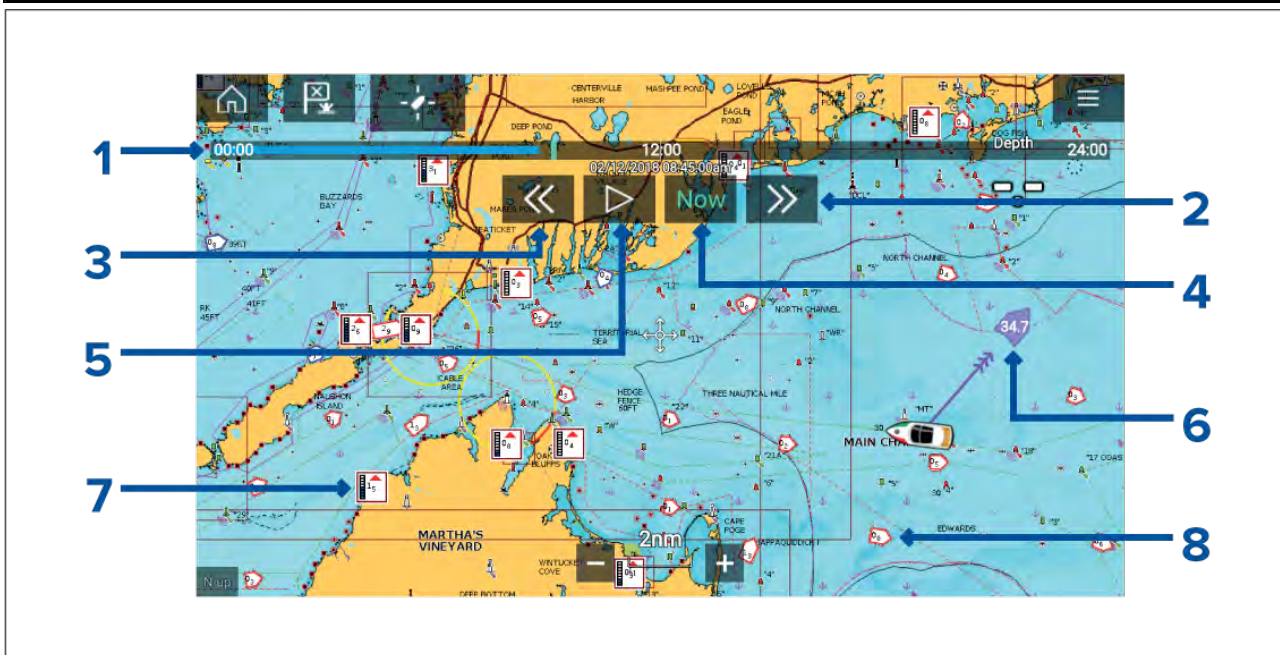

1. Animation progress bar — The progress bar is Blue for the current 24 hour period, or Green when playing animations from a different day.
2. Skip forwards — Skips forwards in user defined intervals, when the end of the progress bar is reached skipping forward will progress to the next day.
3. Skip backwards — Skips backwards in user defined intervals. When the beginning of the progress bar is reached, skipping backward will regress to the previous day.
4. Skip to the actual date / time — Position data is required from your GNSS (GPS) receiver to obtain current date and time.
5. Play / Pause animation — When the animation is playing it will cycle through the current 24 hour period continuously.
6. Own vessel tide (Set and Drift) vector.
7. Dynamic tide height graphic.
8. Dynamic current graphic.

Important:

The data provided in the Tide and Current graphs and graphics is for information purposes only and must NOT be relied upon as a substitute for prudent navigation. Only official government charts and notices to mariners contain all the information needed for safe navigation.

Using animation controls

The animation controls can be selected using the Touchscreen, alternatively you can use the MFD's physical buttons or a RMK controller to control animations as described below:

With the Chart app set to **Tides mode**.

1. Select **Animate tides** from the menu.
2. Use the **Left** button on the Uni-controller to skip forwards in user defined intervals.

- Use the **Right** button on the Uni-controller to skip backwards in user defined intervals.
- Use the Uni-controller's **OK** button to Play or Pause the animation.

You can define the User skip time interval from the Advanced menu: **Menu > Settings > Advanced > Tide animation interval.**

Setting a specific date for animations

You can select a specific date for the Tide and Current animation predictions.

- Select **Select date** from the main menu.
- Use the **Up** and **Down** arrows to change the date to the required day.
- Select **Save.**

The animation will be set for the specified date.

Tide station information

Depending on your cartography, Tide station information may be available at the location of Tide stations.

Tide station symbol

	<p>The location of Tide stations is marked on the Chart using a diamond-shaped symbol with a 'T' in the middle.</p> <ul style="list-style-type: none"> The symbol is colored Red when using Navionics cartography. The symbol is colored Black when using C-Map cartography.
--	--

Dynamic tide graphic

Using Navionics cartography, when the Tides layer is enabled or when the Chart app is in **Tides mode**, the standard symbol is replaced with a dynamic Tide height graphic:

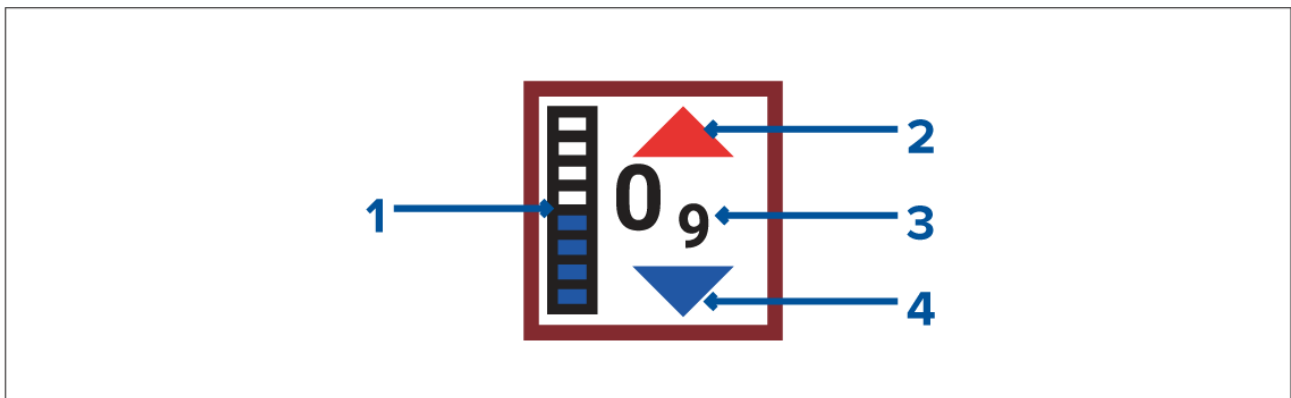

- Tide bar — The tide bar plots the current tide height against the maximum predicted tide height for that day.
- Red arrow indicates tide height is increasing.
- Tide height — Tide height is displayed in user-selected depth units, with decimals displayed in subscript. Decimals are not shown for values of 10 or greater.
- Blue arrow indicates tide height is decreasing.

Tide graph

Tide graphs are available with applicable Navionics and C-Map cartography by selecting **more options** and then **Tide station** from the Tide station's context menu.

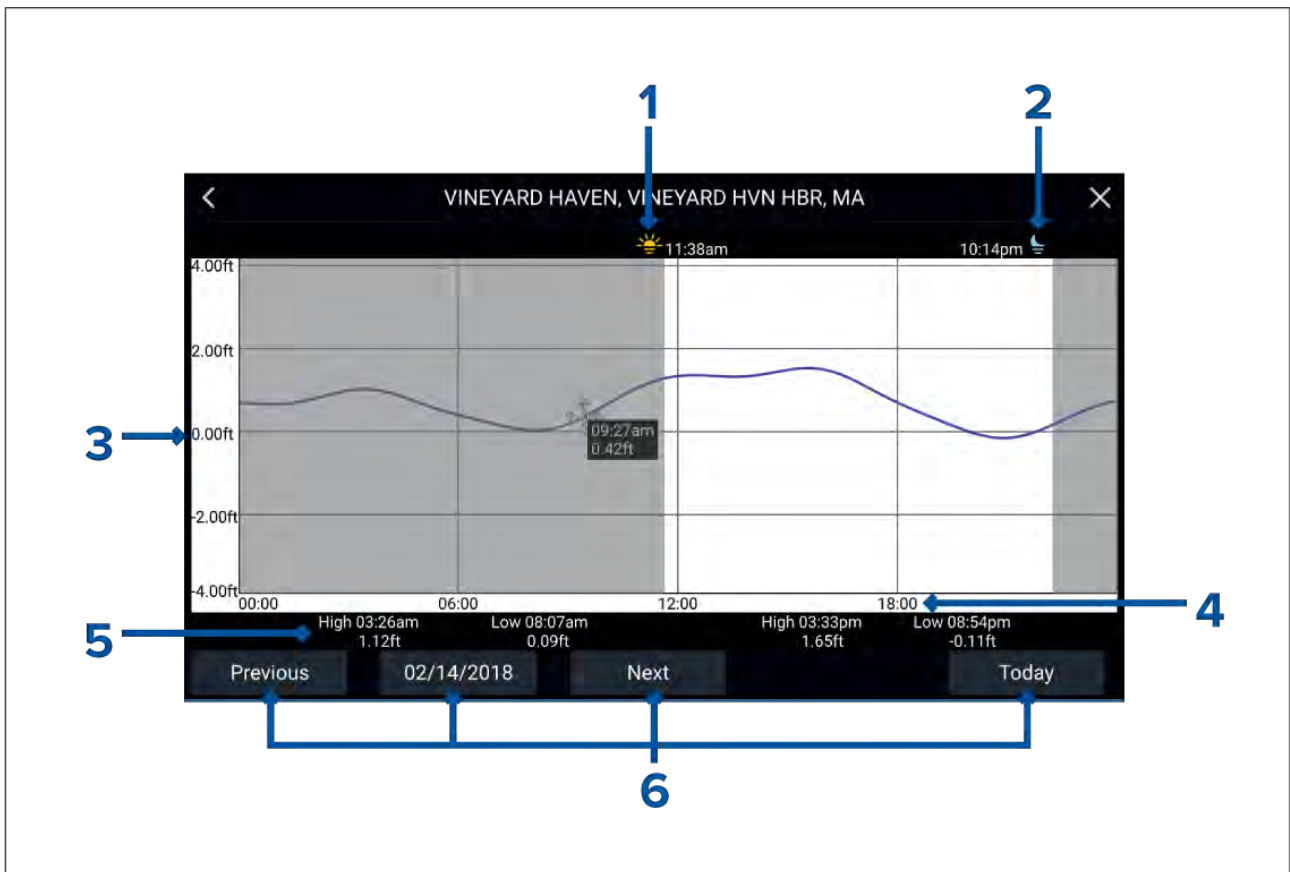

1. **Sunrise** — Indicates time of sunrise.
2. **Sunset** — Indicates time of sunset.
3. **Height** — Provides tide height in selected units.
4. **Time** — Indicates time of day.
5. **Low / High tide** — Indicates the time of low and high tides.
6. **Time and date options** — Use the buttons to view previous, next or today's tide predictions, or enter a date by selecting the date field.

Current station information

Depending on your cartography, Current station information may be available at the location of Current stations.

Current station symbol



	<p>The location of Current stations is marked on the Chart using a diamond-shaped symbol with a 'C' in the middle.</p> <ul style="list-style-type: none"> • The symbol is colored Blue when using applicable Navionics cartography. • The symbol is colored Black when using applicable C-Map cartography.
---	--

Dynamic current graphic

When the Tides layer is enabled or when the Chart app is in **Tides mode**, the standard symbol is replaced with a dynamic Current graphic.

	<p>When using Navionics cartography the dynamic Current graphic is an arrow pointing in the direction of the current flow. Arrow length indicates the speed of the current; the longer the arrow, the faster the speed. The arrow's border indicates current status:</p> <ul style="list-style-type: none"> • Red = increasing current speed. • Blue = decreasing current speed. <p>Current speed is shown inside the arrow. Current speed is displayed in user-selected speed units, with decimals displayed in subscript. Decimals are not shown for values of 10 or greater. If tidal conditions are "slack", the word "SLACK" appears in a box with a Blue border.</p>
---	--

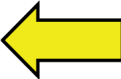
When using C-Map cartography, arrows are used to indicate the direction of current flow. The size and color of the arrow indicates the strength of the current:

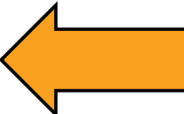
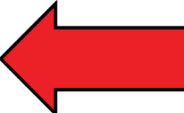
	Yellow	0 to 0.1 Knots
	Yellow	0.2 to 1.0 Knots
	Orange	1.1 to 2.0 Knots
	Orange	2.1 to 3.0 Knots
	Red	>3.0 Knots

Current graph

Current graphs are available by selecting **more options** and then **Current station** from the Current station's context menu.

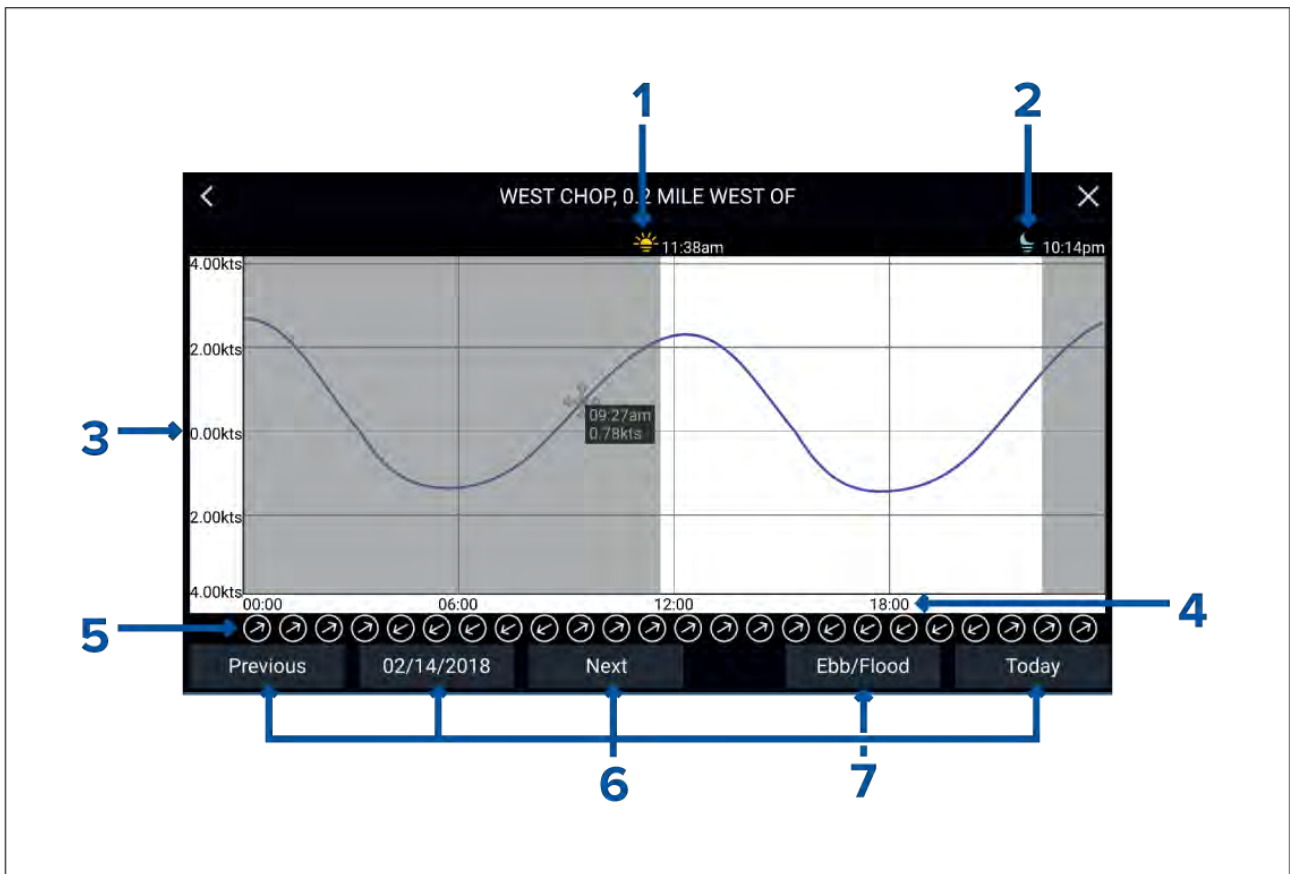

1. **Sunrise** — Indicates time of sunrise.
2. **Sunset** — Indicates time of sunset.
3. **Speed** — Provides current speed in selected units.
4. **Time** — Indicates time of day.
5. **Direction** — Indicates the direction of the current (relative to North).
6. **Time and date options** — Use the buttons to view previous, next or today's tide predictions, or enter a date by selecting the date field.
7. **Ebb / Flood** — Displays a list showing ebb, slack and flood tides.

Displaying tide or current graphs

1. Select a tide or current station symbol or dynamic graphic.
2. Select **more options** from the context menu.
3. Select **Tide station** or **Current station**

Note:

You can also access tide and current graphs by selecting **More info** from the pop-over options when performing a **Find nearest** search for tides.

8.10 RealBathy™

You can create precise personal bathymetric charts in realtime using Raymarine's RealBathy™ feature. When using the RealBathy™ feature, new contour lines are drawn in realtime on the screen based on your transducer's depth readings. Color shading is used to reflect depth, with the darkest shades signifying the shallowest area. The sonar data is recorded to the inserted memory card.

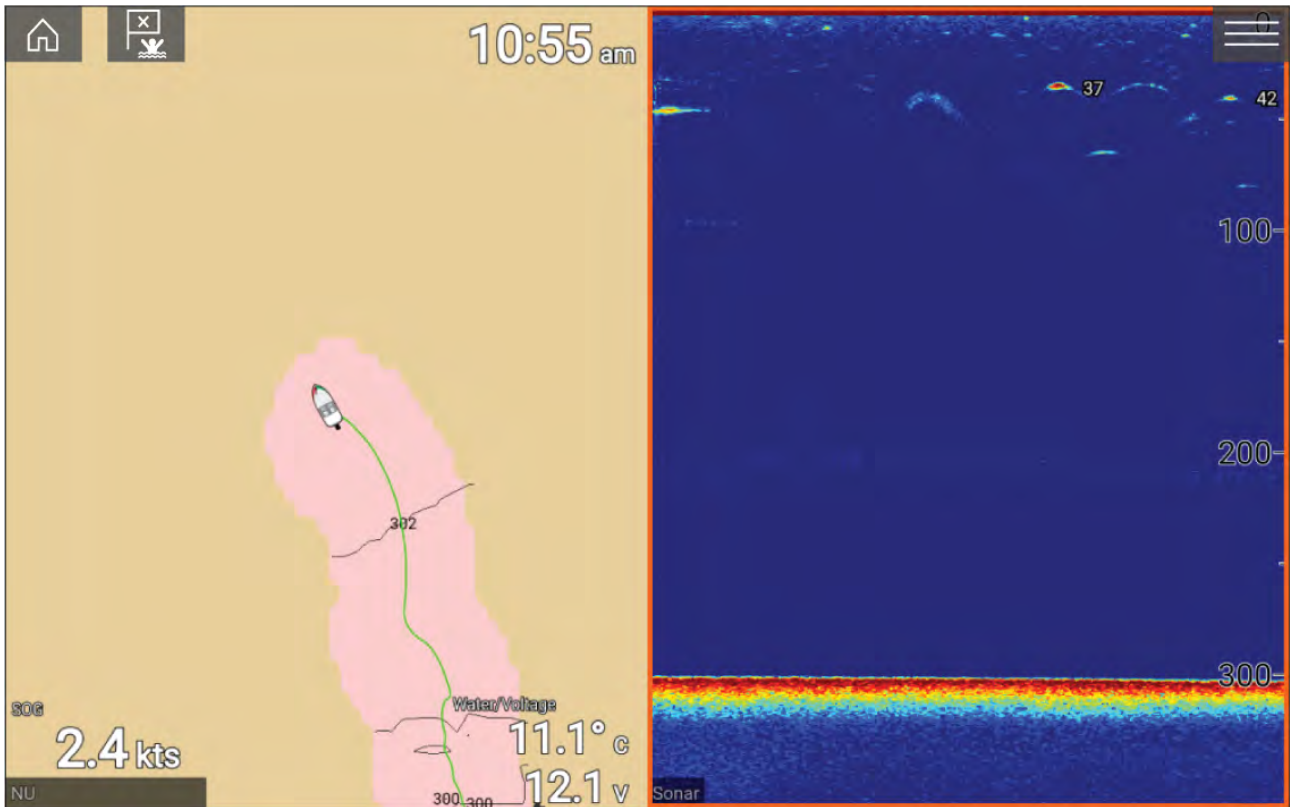

Requirements

The Realbathy feature requires the following:

- LightHouse™ software version 3.9 or later.
- LightHouse™ NC2 charts, which must include tide station information for the location you wish to survey.
- MicroSD card with sufficient free space to record depth and bathymetry data.
- You must ascertain the distance above the bottom face of your depth transducer to the waterline, as shown in the following illustration:

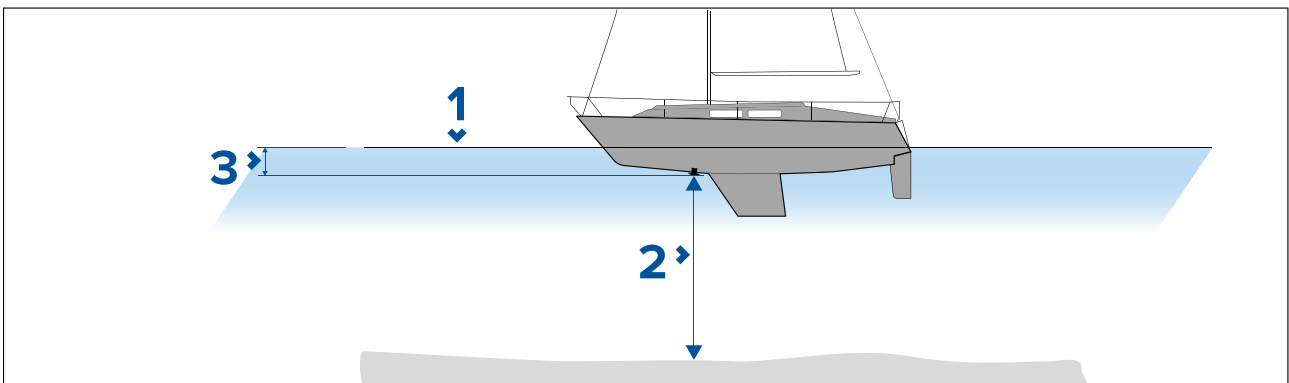

1. Waterline.
2. Water depth below transducer face.
3. Distance above the bottom face of your depth transducer to the waterline.

Setting up and creating RealBathy contours

Important:

- You will need to know the distance above the bottom face of your transducer to the waterline.
- For tidal environments, ensure you have LightHouse™ NC2 cartography that includes tide station information for your location.

From the chart app.

1. Insert your LightHouse™ NC2 chart card into the display's card reader.

2. Select your LightHouse™ chart card as your cartography for the chart app.

For details on choosing your cartography refer to: [Selecting a chart card](#)

3. Enter the distance above the bottom face of your transducer to the waterline in the **Waterline to tdc**: setting field.

4. Enable the **RealBathy** toggle switch, located in the **Depths** menu: **Menu > Depths**

5. Select the relevant **Height correction** option:

- **None** — No corrections are made.
- **Tidal** — Uses nearby tide station data to correct height. When **Tidal** is selected a tidal station search is performed and a list of available stations is displayed. Select the closest tide station to your location.
- **Lake level** — User specified value using the water level marker for your location.

Note:

To ensure accurate contour depths it is recommended that:

- in tidal environments (for example, seas and oceans) you use LightHouse™ NC2 cartography that includes tide station information and select the tide station closest to your location;
- in fresh water environments (for example, lakes), select **Lake level** in the **Height correction:** field and then enter the current reading from the water level marker for your location into the field located under the height correction option.

6. Adjust the **Visibility:** setting to the desired transparency.

100% provides full visibility of the RealBathy contours; as the percentage decreases the chart detail behind the RealBathy contours becomes more visible.

7. Select the required **Density:** setting.

Steep drop-offs can result in overlapping contour lines; lowering the density in these situations provides a clearer view.

8.11 Find nearest

The Find nearest feature allows you to select a location and search for nearby objects.

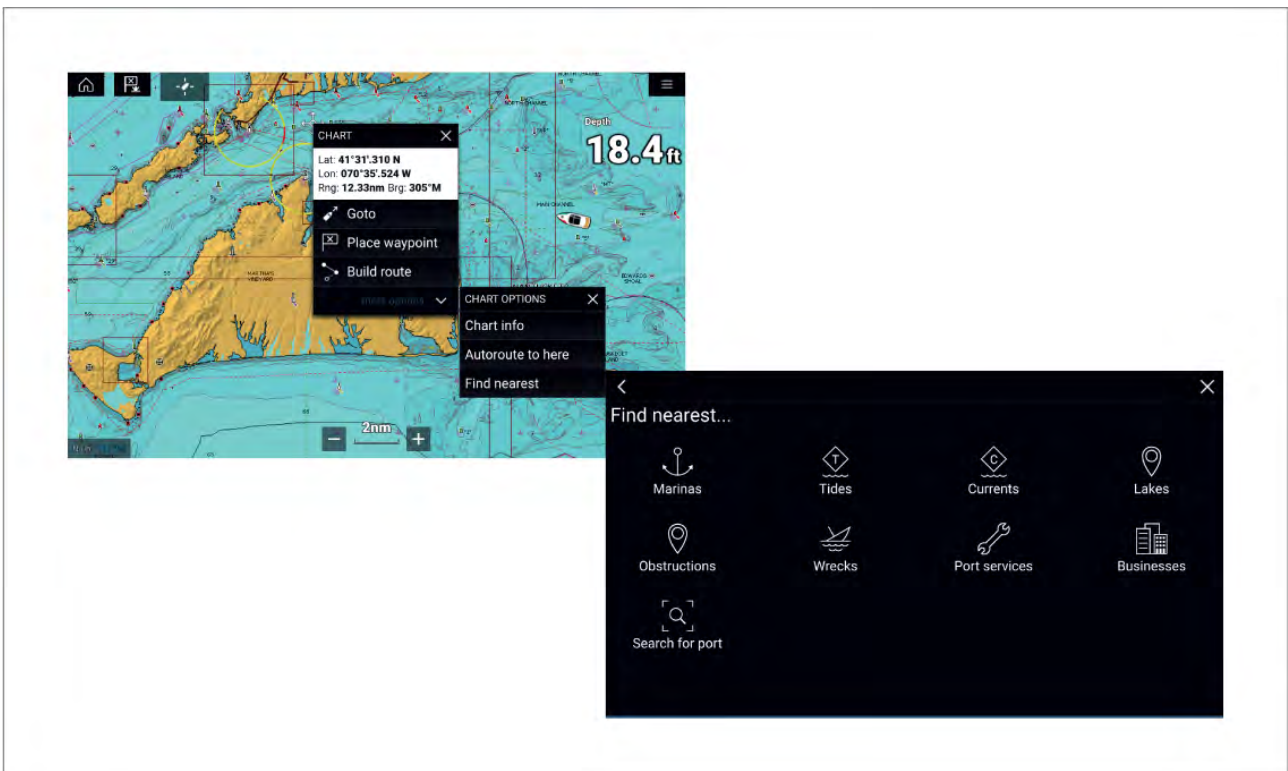

The objects available depend on the cartography type you are using:

Object	LightHouse	Navionics®	C-MAP®
Marinas	✗	✓	✓
Tide Station	✗	✓	✓
Current Station	✗	✓	✓
Lakes	✗	✓	✓
Obstructions	✓	✓	✓
Wrecks	✓	✓	✓
Port Services	✓	✓	✓
Businesses	✗	✓	✗
Port (Search by name)	✗	✓	✓
Point of Interest	✗	✗	✓
Outdoor Recreational Areas (ORA)	✗	✗	✓
ORA Services	✗	✗	✓
Small Craft Facility	✓	✗	✗
Harbor Facility	✓	✗	✗

Search using find nearest

To search for nearby objects, follow the steps below.

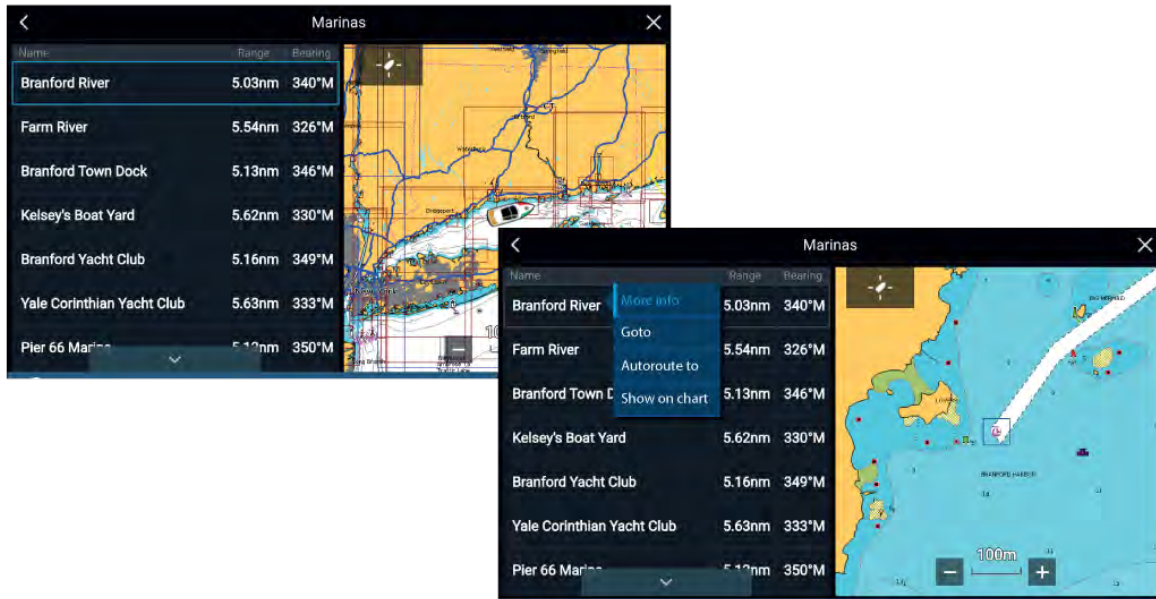

Note:

The list is sorted by an object's proximity to the selected location. However, the Range and Bearing displayed is relative to your vessel's position.

1. Select a location near where you want to search.
The Chart context menu is displayed.
2. Select **more options**.
3. Select **Find nearest**.
4. Select the required object type.
5. If required, select a sub-category or when searching for a port, use the onscreen keyboard to enter a port name and select **Search**.
6. A list of nearby objects of the type selected is displayed.
7. Select an object from the list.
The Pop-over menu is displayed and the **LiveView** on the right of the screen will highlight and zoom to the selected object.
8. From the Pop-over menu you can:
 - i. View more information about the object by selecting **More info**.
 - ii. Navigate to the selected object by selecting **Goto**.
 - iii. Create an automatic route to the selected object by selecting **Autoroute to**.
 - iv. Display the selected object in the Chart app by selecting **Show on chart**.

8.12 SonarChart™ Live

You can create personal bathymetry charts using your depth transducer and the SonarChart™ Live feature, available with compatible Navionics® electronic cartography cards.

Note: Before using SonarChart™ Live ensure you have correctly configured your transducer depth settings.

When using SonarChart™ Live, new contour lines are drawn in real time on the screen based on your transducer's depth readings. Color shading is used to reflect depth, with dark red signifying the shallowest area. The sonar data is recorded to your cartography card and is shared with Navionics when you update your chart card online.

Tide correction

SonarChart™ Live records the actual readings from your depth transducer under current tide / water level conditions. You can enable automatic adjustment of depth readings based on normalized low tide / low water level depth data taken from a nearby Tide station.

Enabling SonarChart Live

To enable creation of real time SonarChart™ Live bathymetry lines:

With your transducer depth settings correctly configured and compatible cartography selected:

1. Select the **Depth** tab from the Chart app settings menu: **Chart app > Menu > Settings > Depth**.
2. Enable **Sonar logging**.
3. Enable **SonarChart Live**.
4. Select the **Visibility** setting field, and adjust to your preferred value.
5. If required, enable **Tide correction**.

8.13 UAV Chart integration

When a compatible UAV with a GNSS (GPS) position fix is connected to your MFD, a UAV icon representing the position of the UAV is displayed in the Chart app.

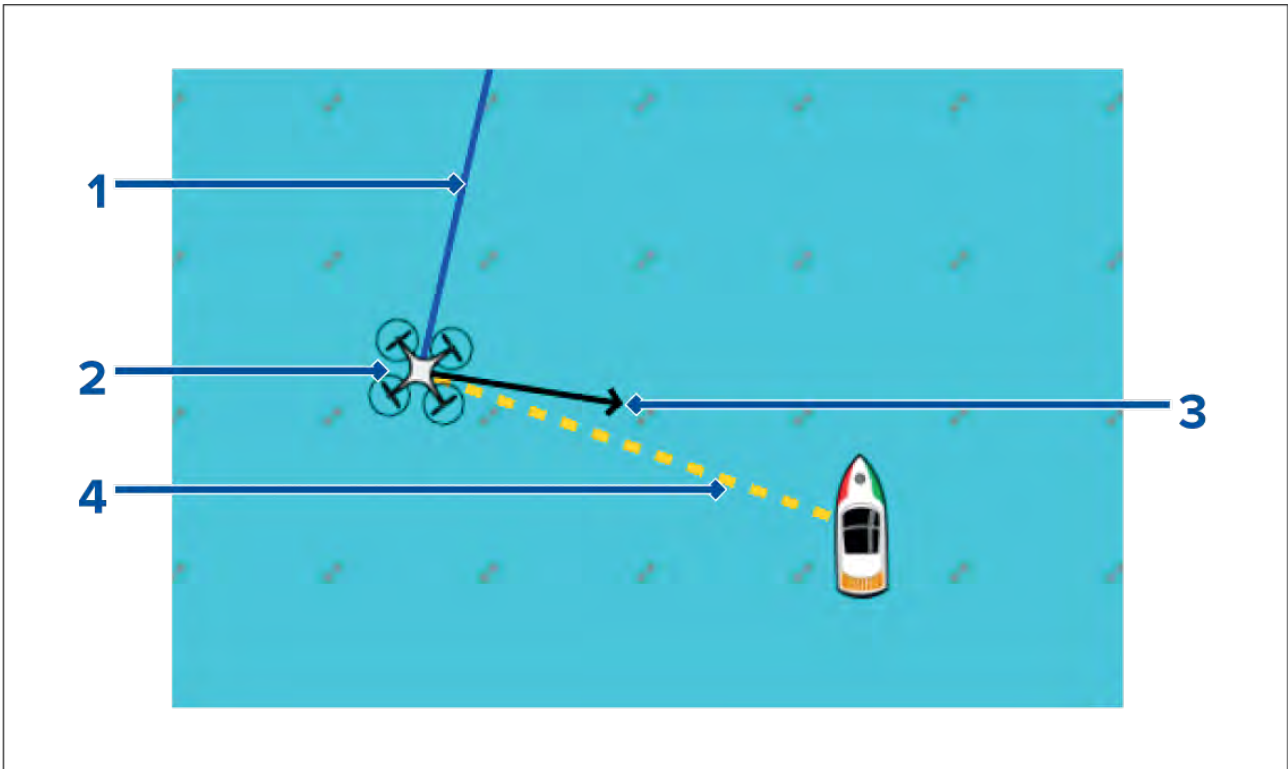

1	<p>UAV COG The direction of the Blue line indicates the UAV's current Course Over Ground (COG). The length of the line indicates the UAV's predicted position when the specified vector Reference period has passed. The Vector Reference period can be adjusted from the vessel icon's context menu.</p>
2	<p>UAV Icon Displayed when the UAV option is enabled in the Chart app settings, and your UAV has a GNSS (GPS) position fix.</p>
3	<p>Camera heading The Black Camera heading arrow is fixed to provide an indication of the direction the UAV's camera is pointing towards.</p>
4	<p>Line to vessel The Yellow dotted line represents the angle of the UAV's position relative to your vessel.</p>

Showing or hiding the UAV icon

The UAV icon is displayed by default in the Chart app. The icon can be hidden if required.

From the Chart app menu:

1. Select **Settings**.
2. Select the **Layers** tab.
3. Select the **UAV**: toggle switch.

Selecting the UAV toggle switch will make the UAV icon visible (on) or invisible (off).

Performing a UAV Goto

When your UAV is in flight you can select a location or object in the Chart app and perform a **UAV Goto** (your UAV will fly to the selected location or object and hover).

1. Select a location or object in the Chart app.

The Chart context menu is displayed.

2. Select **More**.
3. Select **UAV Goto**.

A UAV waypoint marker is placed to signify the UAV's destination and the UAV will fly to that location.

You can stop a UAV Goto at anytime by selecting the Red **Cancel UAV Goto** that is displayed onscreen in the UAV app, when a UAV Goto is active. Cancelling a UAV Goto will stop the Goto action and the UAV will hover in its current location.

A UAV Goto can be cancelled at any time by selecting **Stop UAV Goto** from the Chart context menu.

8.14 ClearCruise™ Augmented Reality

The Chart app has additional Augmented Reality features, which are available when an AR200 and a compatible IP camera are connected.

Augmented Reality features must also be enabled and configured in the Video app.

With the Augmented Reality features enabled, the AIS Target, Waypoint and Chart Object data available in the Chart app will also be available in the video app, where the data will be overlaid onto the live video feed.

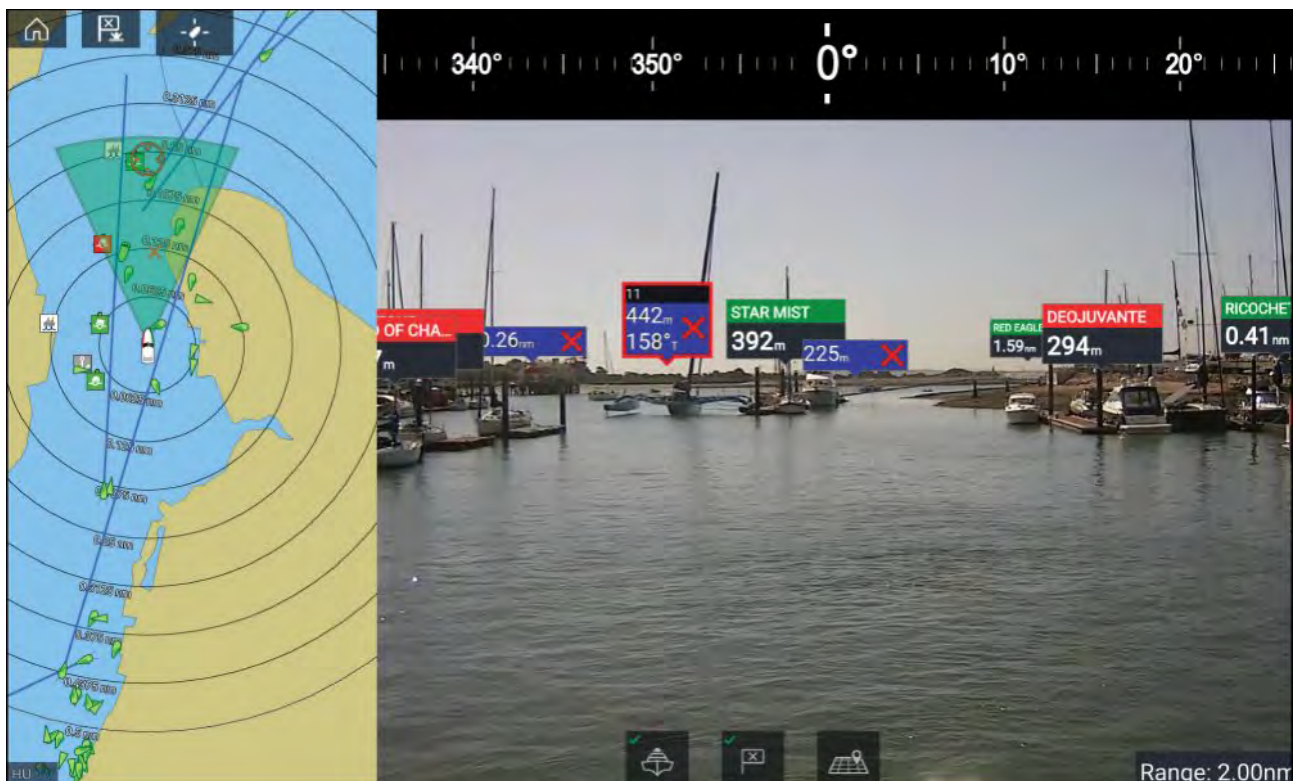

For further information on ClearCruise™ Augmented Reality, refer to [p.274 – ClearCruise™ features](#)

Field of View

The Field of View (FOV) cone acts as a range indicator to illustrate the area of coverage of the camera with respect to displaying chart objects in the Video app as part of the ClearCruise™ Augmented Reality features.

Chart objects that are within the scope of the displayed FOV cone will be displayed in the Video app as “flags”. For more information on flags, refer to [p.282 – Augmented Reality flags](#)

The area of coverage of the FOV cone is determined by:

- The camera’s horizontal Field of View (FOV). This setting can be adjusted in the Video app: **Video settings > Camera Setup tab**.
- The Augmented Reality Range Limit. For more information refer to [p.287 – Range limit](#). You can also manually specify the maximum range limit; refer to [p.286 – ClearCruise settings \(Augmented Reality\)](#) for more information. When you adjust this setting, the FOV cone in the Chart app will change accordingly.



The FOV cone can be enabled/disabled in the Chart app settings: **Menu > Settings > Layers**.

8.15 Chart settings menu

The table below lists settings applicable to the Chart app and their location within the app’s **Settings** menu. Available settings are dependent on the cartography in use. If a setting is not displayed then the feature is not compatible with your cartography. If a feature is grayed out then it requires a subscription to activate the feature.

Cartography

Settings	Description	Options
LightHouse Charts Navionics C-MAP	Allows you to select the cartography that you want to use in the current Chart app.	<ul style="list-style-type: none"> • List of available cartography

Layers tab

Settings	Description	Chart vendor and Layer options
Chart detail Layer options: <ul style="list-style-type: none"> • Low • Medium • High 	Allows you to select the level of detail displayed onscreen for vector-based cartography.	Chart vendor: <ul style="list-style-type: none"> • All (Vector)
Aerial Layer options: <ul style="list-style-type: none"> • On • Off 	Enables and disables the display of a photographic aerial overlay.	Chart vendor: <ul style="list-style-type: none"> • Navionics • C-MAP (Vector)
AIS Layer options: <ul style="list-style-type: none"> • On • Off 	Enables and disables the display of AIS targets in the Chart app. Requires AIS hardware.	Chart vendor: <ul style="list-style-type: none"> • All
Radar Layer options: <ul style="list-style-type: none"> • On • Off 	Enables and disables the display of your Radar scanner's image in the Chart app. Requires Radar scanner hardware.	Chart vendor: <ul style="list-style-type: none"> • All
Range rings Layer options: <ul style="list-style-type: none"> • On • Off 	Enables and disables the display of Radar-like range rings in the Chart app.	Chart vendor: <ul style="list-style-type: none"> • All
FOV: Layer options: <ul style="list-style-type: none"> • On • Off 	Field of View Enables and disables the ClearCruise™ Augmented Reality (AR) camera's field of view (FOV) overlay in the Chart app.	Chart vendor: <ul style="list-style-type: none"> • All
Weather Radar Layer options: <ul style="list-style-type: none"> • On • Off 	Enables Weather Radar precipitation data overlay in the Chart app. Only available when connected to a compatible SiriusXM weather receiver with a valid subscription.	Chart vendor: <ul style="list-style-type: none"> • All Layer options: <ul style="list-style-type: none"> • On • Off
Tides Layer options: <ul style="list-style-type: none"> • On • Off 	Enables and disables the display of Tide and Current graphics at Tide and Current stations in the Chart app.	Chart vendor: <ul style="list-style-type: none"> • Navionics
EasyView Layer options: <ul style="list-style-type: none"> • On • Off 	Enables and disables the magnification of useful icons and text, making them easier to read.	Chart vendor: <ul style="list-style-type: none"> • Navionics
Community edits Layer options: <ul style="list-style-type: none"> • On • Off 	Enables and disables the display of crowd-sourced data.	Chart vendor: <ul style="list-style-type: none"> • Navionics

Settings	Description	Chart vendor and Layer options
High res bathy Layer options: <ul style="list-style-type: none"> • On • Off 	Enables and disables the display of High Resolution Bathymetry charts, which provide improved bottom detail, contours and structure.	Chart vendor: <ul style="list-style-type: none"> • C-MAP
Sports fishing Layer options: <ul style="list-style-type: none"> • On • Off 	Allows you to display easy-to-use information pages about fishing locations including fish type, size, depth, and reef and bottom composition.	Chart vendor: <ul style="list-style-type: none"> • C-MAP
Marine protected areas Layer options: <ul style="list-style-type: none"> • On • Off 	Allows clear identification of areas where commercial and recreational fishing is prohibited or restricted.	Chart vendor: <ul style="list-style-type: none"> • C-MAP
Fishing AOI Layer options: <ul style="list-style-type: none"> • On • Off 	Enables and disables the display of Fishing AOIs (Areas Of Interest).	Chart vendor: <ul style="list-style-type: none"> • C-MAP
ActiveCaptain Layer options: <ul style="list-style-type: none"> • On • Off 	Enables and disables the display of crowd-sourced data.	Chart vendor: <ul style="list-style-type: none"> • C-MAP

Depths tab

Settings	Description	Chart vendor and Setting options
Show soundings Setting options: <ul style="list-style-type: none"> • None • Manual • All 	Enables and disables the display of depth soundings on the chart. When set to Manual, depth soundings will be shown from zero to the maximum depth you specify.	Chart vendor: <ul style="list-style-type: none"> • LightHouse (Vector) • Navionics • C-MAP
Show contours Setting options: <ul style="list-style-type: none"> • None • Manual • All 	Enables and disables the display of depth contours on the chart. When set to Manual, contours will be shown from zero to the maximum depth you specify.	Chart vendor: <ul style="list-style-type: none"> • Navionics • C-MAP
Shallow water Setting options: Numeric value	Determines the depth at which the Shallow contour is displayed. The Shallow contour cannot be set to a value greater than the Safety or Deep contour value.	Chart vendor: <ul style="list-style-type: none"> • LightHouse (Vector)
Safe water from Setting options: Numeric value	Determines the depth at which the Safety contour is displayed. The Safety contour cannot be set to a value that is less than the Shallow contour or greater than the Deep contour.	Chart vendor: <ul style="list-style-type: none"> • LightHouse (Vector)

Settings	Description	Chart vendor and Setting options
Deep water from Setting options: Numeric value	Allows you to specify the depth at which Deep water will be displayed.	Chart vendor: <ul style="list-style-type: none"> • LightHouse (Vector) • Navionics • C-MAP
Depth gradient Setting options: <ul style="list-style-type: none"> • Dark to light • Light to dark 	Allows you to specify the gradient shade between shallow and deep.	Chart vendor: <ul style="list-style-type: none"> • LightHouse (Vector) • NC2
Deep water color Setting options: <ul style="list-style-type: none"> • White • Blue 	Allows you to specify the color that will be used to display Deep water.	Chart vendor: <ul style="list-style-type: none"> • Navionics • C-MAP
Sonar logging Setting options: <ul style="list-style-type: none"> • On • Off 	Allows logging of depth and position data to your Navionics chart card.	Chart vendor: <ul style="list-style-type: none"> • Navionics
SonarChart Live Setting options: <ul style="list-style-type: none"> • On • Off 	Enables and disables the Navionics SonarChart Live feature, which enables the realtime creation and display of high resolution bathymetry charts.	Chart vendor: <ul style="list-style-type: none"> • Navionics
Visibility Setting options: <ul style="list-style-type: none"> • 0% to 100% 	Determines the level of transparency used when displaying SonarChart data.	Chart vendor: <ul style="list-style-type: none"> • Navionics
Tide correction Setting options: <ul style="list-style-type: none"> • On • Off 	Enables Sonar logging depth measurements to be offset by tide height data from nearby tide stations.	Chart vendor: <ul style="list-style-type: none"> • Navionics
Shallow depth shading Setting options: <ul style="list-style-type: none"> • On • Off 	Enables and disables the identification of areas deemed to be shallow. When set to On, a red hatched area is displayed in areas shallower than the specified depth.	Chart vendor: <ul style="list-style-type: none"> • Navionics
Density Setting options: <ul style="list-style-type: none"> • Very high • High • Medium • Low 	Determines the density of available depth contours.	Chart vendor: <ul style="list-style-type: none"> • Navionics
Fishing Range Setting options: <ul style="list-style-type: none"> • On • Off 	You can set up a Fishing Range by enabling Fishing Range and specifying a minimum and maximum depth. Areas on the chart that are between these depths will be colored White; areas outside of these depths will be colored Blue.	Chart vendor: <ul style="list-style-type: none"> • Navionics

Settings	Description	Chart vendor and Setting options
Record depth data Setting options: <ul style="list-style-type: none"> • On • Off 	Enables depth and position data to be recorded to memory card.	Chart vendor: <ul style="list-style-type: none"> • LightHouse (Vector)
Waterline to tdc Setting options: Numeric value	Enter the distance between the waterline and your depth transducer.	Chart vendor: <ul style="list-style-type: none"> • LightHouse (Vector)
Save to Setting options: Numeric value	When a suitable MicroSD card has been inserted the free space available for recording depth data and RealBathy is displayed.	Chart vendor: <ul style="list-style-type: none"> • LightHouse (Vector)
RealBathy Setting options: <ul style="list-style-type: none"> • On • Off 	Displays previously recorded RealBathy™ data saved on memory card on the chart.	Chart vendor: <ul style="list-style-type: none"> • LightHouse (Vector)
Visibility Setting options: Numeric value	Determines the transparency of the RealBathy data and SonarChart live data displayed onscreen.	Chart vendor: <ul style="list-style-type: none"> • LightHouse (Vector)
Height correction Setting options: <ul style="list-style-type: none"> • None • Tidal • Lake level 	Determines the level of height correction applied to RealBathy and depth data.	Chart vendor: <ul style="list-style-type: none"> • LightHouse (Vector)
Safety depth shading Setting options: Numeric value	Determines the depth at which the Safety contour is displayed.	Chart vendor: <ul style="list-style-type: none"> • LightHouse (Vector)
Density Setting options: <ul style="list-style-type: none"> • Low • Medium • High • Very high 	Selects the density of available depth contours. <div style="border: 1px solid black; padding: 5px; margin-top: 10px;"> <p>Note: The 'Very high' option is only available when using Navionics cartography.</p> </div>	Chart vendor: <ul style="list-style-type: none"> • LightHouse (Vector) • Navionics

View & Motion tab

Settings	Description	Options
Chart motion	<p>Relative motion In Relative motion mode the vessel icon remains fixed onscreen and the chart area moves relative to your position. In this mode you can adjust your vessel's fixed position using the Boat position setting.</p> <p>True motion In True motion mode the chart is fixed and your vessel icon moves around the chart. As your vessel's position reaches the edge of the screen, the chart is redrawn to reveal the area in front of your vessel.</p> <p>Auto range</p>	<ul style="list-style-type: none"> • Relative motion • True motion • Auto range

Settings	Description	Options
	In Auto range the largest possible scale is maintained that will display both your vessel and the destination / target waypoint simultaneously.	
Chart orientation	<p>North-up In North-up the top of the screen always points towards north. As your vessel's heading changes, the vessel icon rotates accordingly.</p> <p>Head-up In Head-up the top of the screen always points towards your vessel's current heading, and as your heading changes the chart rotates accordingly.</p> <p>Course-up In Course-up the top of the screen always points towards your destination, and as your destination changes the chart rotates accordingly.</p>	<ul style="list-style-type: none"> • North-up • Head-up • Course-up
Boat position	<p>The boat position determines the position of your vessel icon onscreen. The default is Center but you can adjust this to provide a greater distance in front of your vessel.</p> <p>Your boat position can only be changed when Chart motion is set to Relative motion.</p>	<ul style="list-style-type: none"> • Center • Partial offset • Full offset
Sync view with other charts:	All charts with Sync turned On will synchronize orientation and position.	<ul style="list-style-type: none"> • On • Off

Laylines

Setting	Description	Options
Sail Performance	<p>Choose between Layline types:</p> <ul style="list-style-type: none"> • Not set — Laylines are disabled • Fixed Angles — the vectors are created based on specified Upwind and Downwind angles. These angles are set by default to 45° and 165° respectively and can be configured in the menu • Polars — the vectors use an imported polar table for your vessel to create the laylines 	<ul style="list-style-type: none"> • Not set • Fixed • Polar
(Fixed angle) Upwind angle	<ul style="list-style-type: none"> • Set the angle of upwind layline calculations 	<ul style="list-style-type: none"> • 15° to 70° • 45° (default)
(Fixed angle) Downwind angle	<ul style="list-style-type: none"> • Set the angle of downwind layline calculations 	<ul style="list-style-type: none"> • 125° to 175° • 165° (default)
(Polar) Polar	<ul style="list-style-type: none"> • Select the Polar table that will affect your layline calculation. Selecting your vessel's make and model will provide better calculated laylines to follow when sailing 	<ul style="list-style-type: none"> • List of available Polars
Display Layines on this chart	<ul style="list-style-type: none"> • Display or hide laylines on the current Chart app instance 	<ul style="list-style-type: none"> • On • Off

Setting	Description	Options
Adjust for tides	<ul style="list-style-type: none"> Adjust the laylines to take into account tidal flow 	<ul style="list-style-type: none"> On Off
Boat type	<ul style="list-style-type: none"> Set your vessel's boat type to provide more accurate leeway calculation 	<ul style="list-style-type: none"> List available Boat types

Advanced tab

Settings	Description	Options
Chart orientation	The orientation of the chart affects alignment relative to your vessel, route or North.	<ul style="list-style-type: none"> North-up Head-up Course-up
Enhanced AIS targets	Switches between using standard and enhanced AIS targets.	<ul style="list-style-type: none"> On Off
Use Radar without heading data	Enables use of Radar overlay without Heading data.	<ul style="list-style-type: none"> On Off
Cursor info boxes	Allows display of the cursor's Range and Bearing from your vessel. When an object is highlighted the object name is also displayed.	<ul style="list-style-type: none"> On Off
Tide animation interval	Allows you to select the time interval used for the Tide and Current animations in Tides mode.	<ul style="list-style-type: none"> 15 minutes to 2 hours in 15 minute steps.
Cartographic objects	Enables and disables the display of cartographic objects. The settings available are dependent on the cartography in use.	<ul style="list-style-type: none"> Navigation marks Navigation mark symbols Rocks Light sectors Routing systems Caution areas Marine features Land features Business services Panoramic photos Roads Additional wrecks Colored seabed areas
Chart appearance	Allows you to change the appearance of the Chart app. The settings available are dependent on the cartography in use.	<ul style="list-style-type: none"> 2D shading Aerial overlay Aerial overlay opacity Relief shading Visibility Grid Chart text Chart boundaries Text/symbol size Deep water color

Settings	Description	Options
		<ul style="list-style-type: none"> • Community edits
My data appearance	You can change how your User data appears in the Chart app.	<ul style="list-style-type: none"> • Waypoints names • Route names • Track names • Route width • Track width • Vector width • Vector length

Weather settings tab

Settings	Description
Wind symbol	Determines whether Arrows or Barbs are used for Wind direction graphics in Weather mode.
Marine zone boundaries	Determines whether marine boundaries are shown in Weather mode.
Watchbox alerts	Enables and disables Watchbox alerts.
Watchbox range	Determines the range from your vessel that Watchbox alerts are displayed
Signal strength	Displays the signal strength of a connected weather receiver.
Receiver ESN	Displays the Electronic Serial Number (ESN) of a connected weather receiver.

Note:

The Weather settings tab is only displayed when the Chart app is set to Weather mode.

Page settings tab

Settings	Description
Data Overlays	Enables configuration of Data overlays, which overlay key information from connected sensors onto the Chart, Radar, Sonar and Camera apps.
Edit split ratio	Enables you to customize the position of the partitions in splitscreen app pages. For example, 50/50, 70/30 etc.

Chapter 9: Weather mode

Chapter contents

- [9.1 Weather mode on page 170](#)
- [9.2 Activating your SiriusXM receiver on page 171](#)
- [9.3 Animated weather on page 172](#)
- [9.4 Weather mode context menu on page 173](#)
- [9.5 Weather Radar layer on page 173](#)
- [9.6 Cities and Surface observation stations layers on page 175](#)
- [9.7 Cloud top and Lightning layers on page 176](#)
- [9.8 Storm cast and Storm tracks layers on page 177](#)
- [9.9 Sea surface temperature and Surface pressure layers on page 178](#)
- [9.10 Wind and Watchbox layers on page 180](#)
- [9.11 Wave direction, height and period layers on page 181](#)

9.1 Weather mode

Weather mode is available in the Chart app if you have a weather receiver and valid subscription. Switching the Chart app to weather mode allows you to overlay weather data and information from your weather receiver.

To enter Weather mode, open the Chart app menu and select **WEATHER**.

Weather mode allows you to track weather systems in relation to your vessel by overlaying live, historical and forecasted weather data directly on the chart. In Weather mode you can also view animated weather graphics and read weather reports. Weather mode sets the **Chart detail** setting to Low and hides other data which increases the visibility of Weather data.

Important:

- Compatible hardware and a valid subscription is required to enable Weather mode.
- By enabling Weather mode you agree to its terms of use.
- Do not use Weather mode for navigation.
- Weather data is only available in North America and its coastal waters.

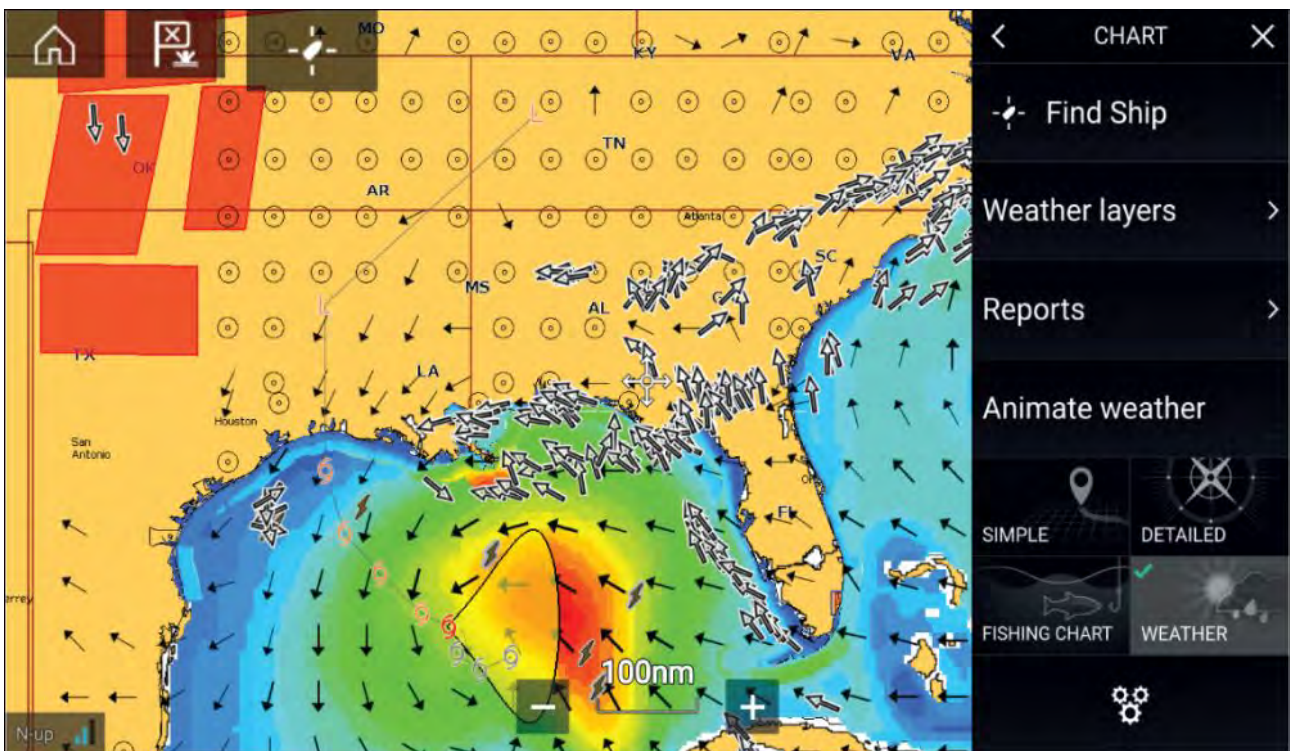

Weather symbols are organized into layers, accessible from the Chart menu: **Menu > Weather layers**. Each layer can be enabled and disabled independently.

The following Layers are available:

Weather radar	Surface pressure
Cities	Surface observation stations
Cloud top	Wind
Lightning	Watchbox
Sea surface temperature	Wave height
Storm cast	Wave period
Storm tracks	Wave direction

In Weather mode the **Chart orientation** is fixed in **North-Up**.

9.2 Activating your SiriusXM receiver

Your MFD is compatible with the SR150 and SR200 SiriusXM receivers. Your receiver must be activated before you can use Weather mode on your MFD.

Note:

Lighthouse Software Version

- LH3.10 – SR200 SiriusXM receiver for Weather mode is compatible on all Axiom Multifunction Displays on the same network as the data master.

The following information is required to activate your SiriusXM receiver:

- Electronic Serial Number (ESN) — The ESN is printed on the product label located on the underside of your SiriusXM receiver. You can also access the ESN from the Weather settings tab in the Chart app: (**Menu > Settings > Weather > Receiver ESN**).
 - Current billing information (if you already have a valid subscription).
 - Desired subscription package.
1. Obtain your SiriusXM receiver's ESN.
 2. Visit the Sirius Marine Weather website: <http://www.siriusxm.com/sxmmarine>, and choose a subscription package.
 3. Follow the "Activate Now" link to activate your receiver online. Alternatively, call 1-855-796-9847.

Once your SiriusXM receiver is activated, you will be able to enable Weather mode and display Weather layers in the Chart app. To enable Weather mode, open the Chart app and select **WEATHER**.

SR200 diagnostics mode

The SR200 diagnostic mode can be accessed from the audio settings menu from the master MFD on the network. The diagnostics mode should be referred to when liaising with Sirius product support.

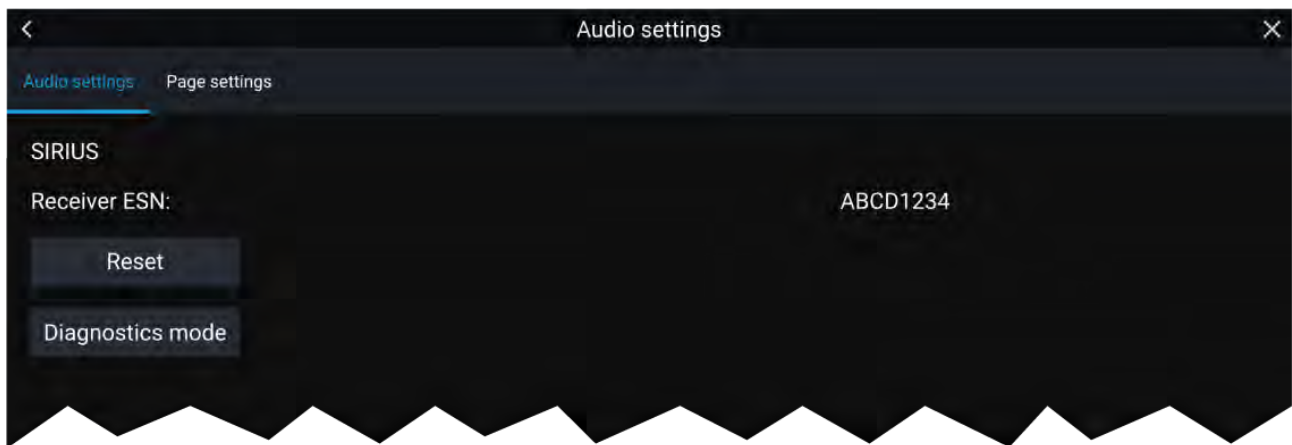

1. Reset — Performs a factory reset and power cycle of the SR200.
2. Diagnostics mode — Displays the SR200's diagnostic information.

Weather receiver status

The status of your weather receiver is displayed in the app info area in the bottom left of the screen.



The app info area displays:

- chart orientation mode — (N-up) orientation is fixed in weather mode.
- signal strength of your Weather receiver:
 - Animated dots = no signal; searching for signal.

- 1 bar (orange) = poor signal strength.
- 3 bars (blue) = good signal strength.
- time and date related to the weather data being displayed.

9.3 Animated weather

In Weather mode you can play weather animations of historical **Weather radar** data and forecasted wind, wave and surface pressure data.

Weather animations can be accessed in Weather mode by selecting **Animate weather** from the menu.

When Animate weather is selected the animation player controls and symbols representing the type of animated data available are displayed onscreen.









Player controls

Player controls include a progress bar, Play/Pause, Fast forward and rewind options.

Animated weather data

Duration of forecasts are dependent on subscription type.

	<p>Weather Radar Historical precipitation data for the previous 2 hours can be played.</p>
	<p>Wind Offshore wind forecast for up to 48 hours. High resolution coastal and inland wind forecast for up to 24 hours.</p>
	<p>Wave height Offshore wave height forecast for up to 48 hours. High resolution coastal wave height forecast for up to 24 hours. Great Lakes wave height forecast for up to 24 hours.</p>

	<p>Wave period Offshore wave period forecast for up to 48 hours. Great Lakes wave period forecast for up to 24 hours.</p>
	<p>Wave direction Offshore wave direction forecast for up to 48 hours. Great Lakes wave direction forecast for up to 24 hours.</p>
	<p>Surface pressure Surface pressure forecast for up to 48 hours.</p>

To exit Animate weather open the main **Menu**.

9.4 Weather mode context menu

The Weather context menu provides Lat/Lon and Range and Bearing information, relative to your vessel. The context menu also provides access to further weather-related data.

	<p>The context menu provides access to:</p> <ul style="list-style-type: none"> • Weather info • Reports. <p>Depending on the symbol selected, the context menu also provides additional data when the Cities, Storm cast, Storm tracks or Watchbox option is selected.</p>
---	--

9.5 Weather Radar layer

With the Weather Radar layer enabled a color coded Radar image is displayed. This image shows a complete view of any precipitation across North America, including the type and intensity. Rain is shown as light green, dark green, yellow, orange and red as intensity increases. Hail, freezing rain and snow are represented with colors from bright pink to blue. The images are displayed as pixels on screen and the resolution of this feature is 2 km per pixel. Coverage includes the Continental US, Canada, and portions of Mexico/Caribbean.

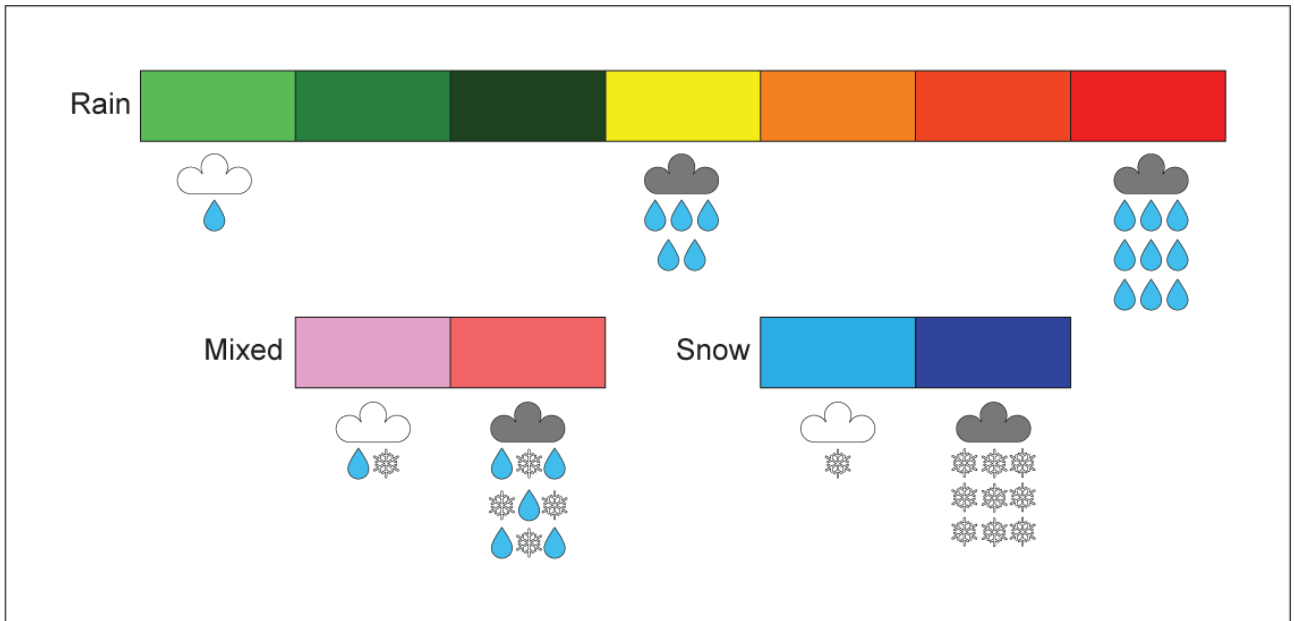
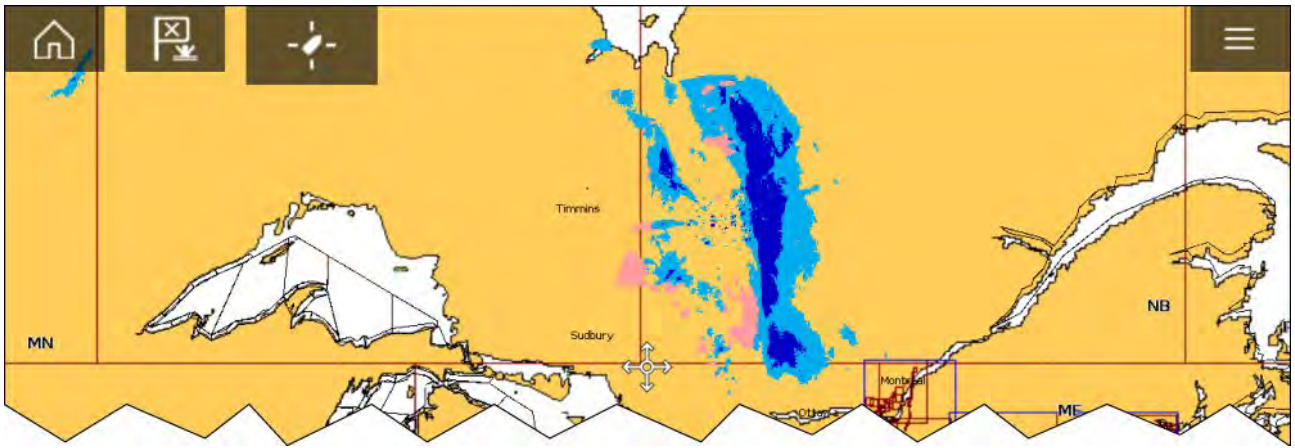

9.6 Cities and Surface observation stations layers

The Cities layer and Surface observation stations layer display symbols which represent the location of Cities and Surface observation stations respectively. The symbols used for Surface observation stations also identify the station type.

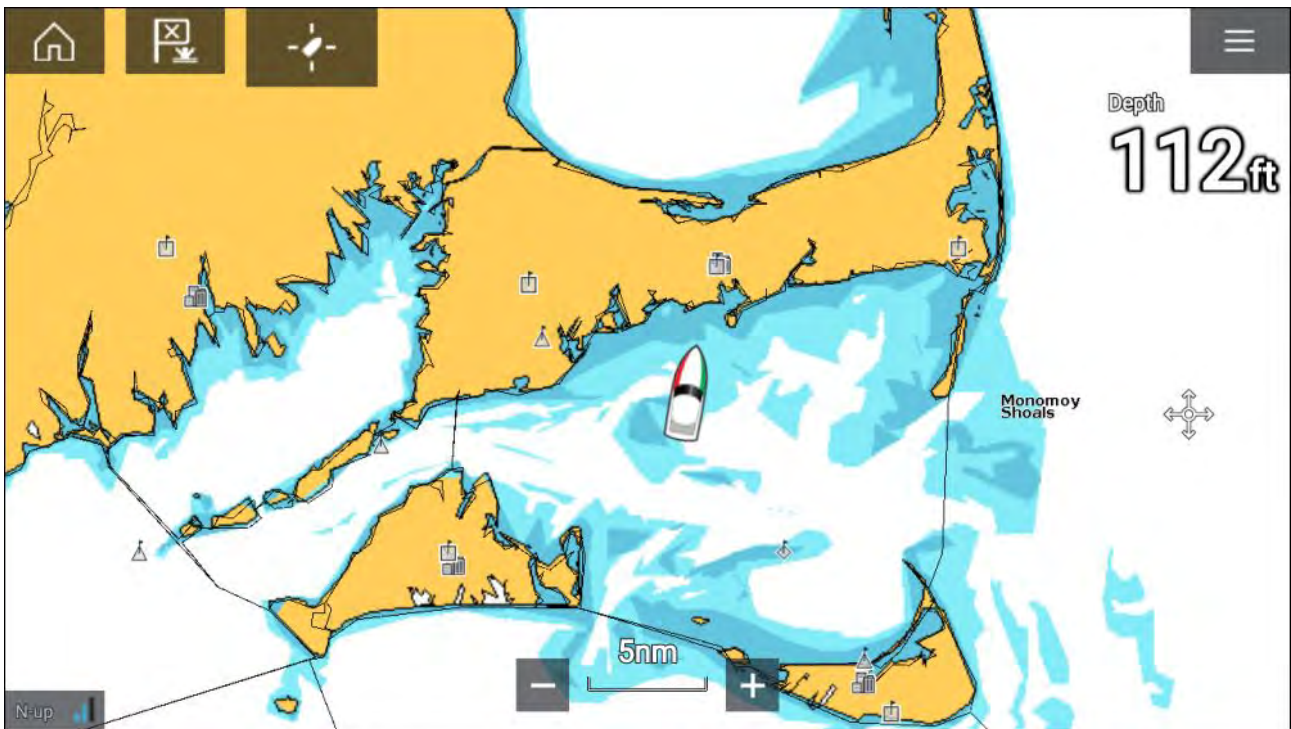

City forecasts are available from the context menu when a City is selected.

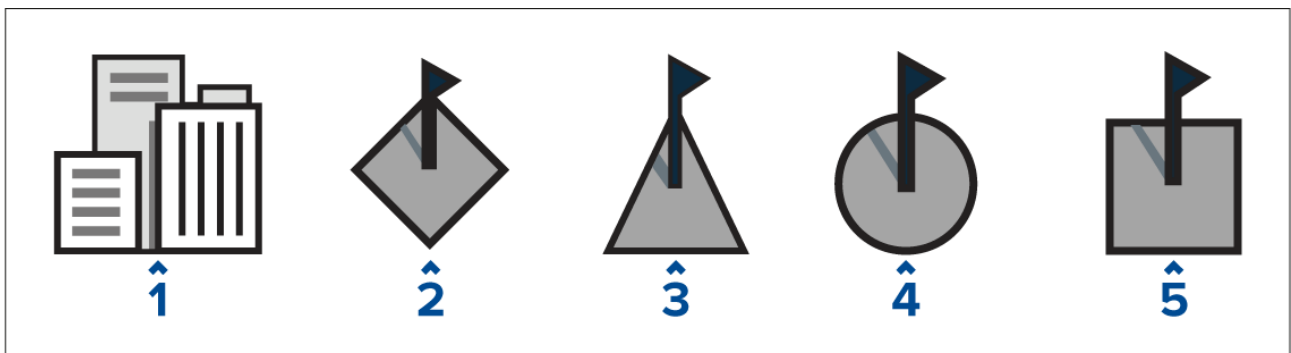

	Layer	Description
1	Cities	City
2	Surface observation station	Buoy station
3	Surface observation station	Coastal-marine automated network (C-MAN)
4	Surface observation station	Weather services international (WSI)

9.7 Cloud top and Lightning layers

The Cloud top layer provides a satellite image of current cloud coverage and the Lightning layer provides symbols to show the location of recent lightning strikes.

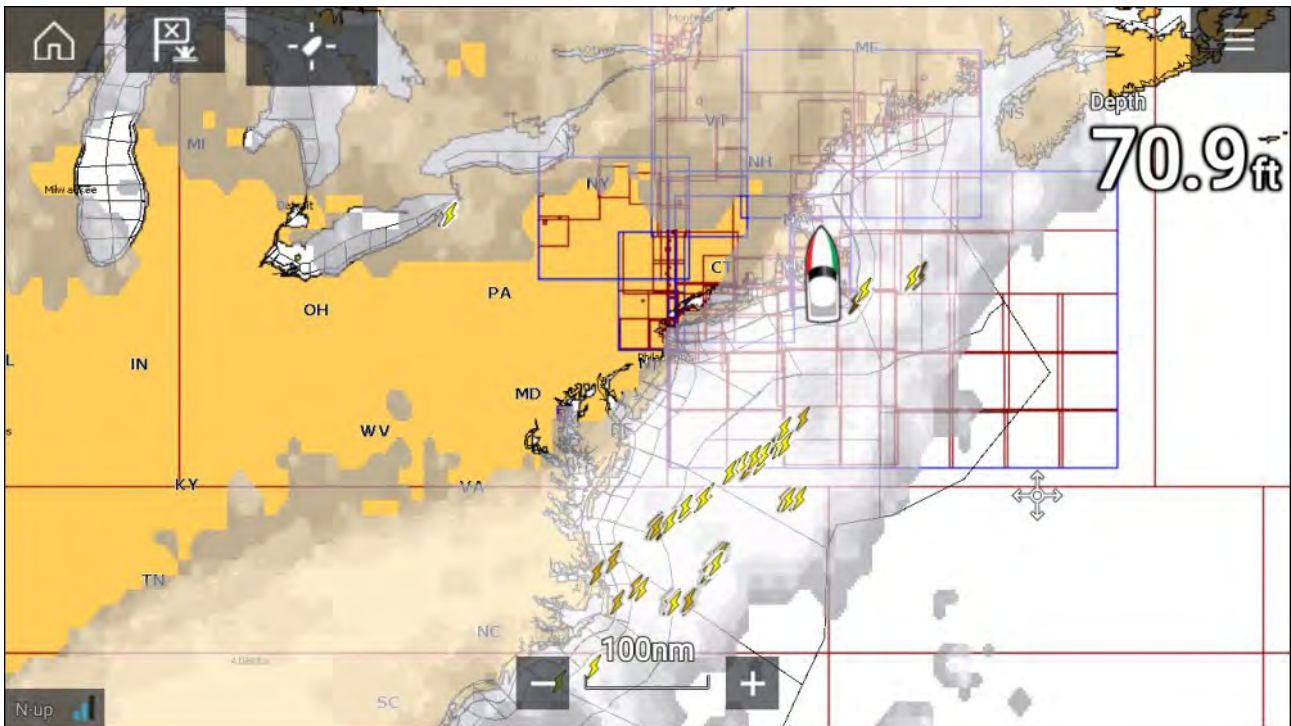

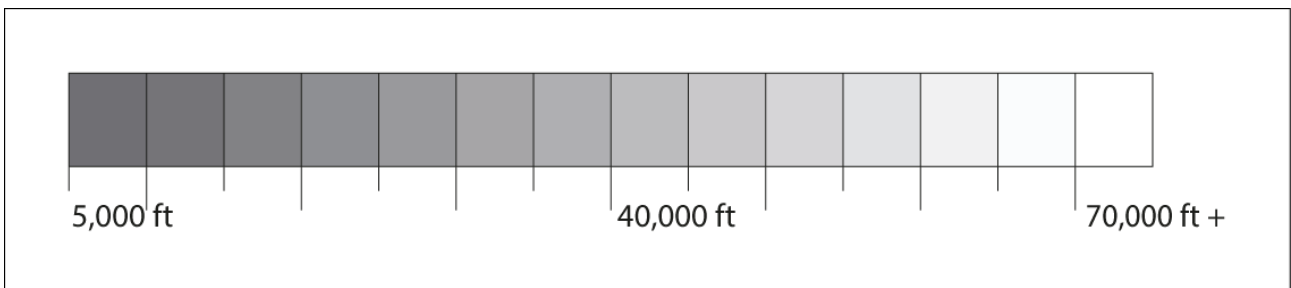

Cloud tops

Cloud tops use Gray shading to identify cloud top height. The shading changes at 5,000 feet increments, from Dark Gray to White. Clouds lower than 5,000 feet are not displayed.



Lightning

The shade of the lightning symbols represent the time the lightning strike was detected.

		
0 to 5 minutes ago	5 to 10 minutes ago	10 to 15 minutes ago

9.8 Storm cast and Storm tracks layers

The Storm cast layer displays arrows that show a storm's direction and speed. The Storm tracks layer identifies a storm's historic, current and forecasted path. Associated wind fields are also shown for the storm's current location.

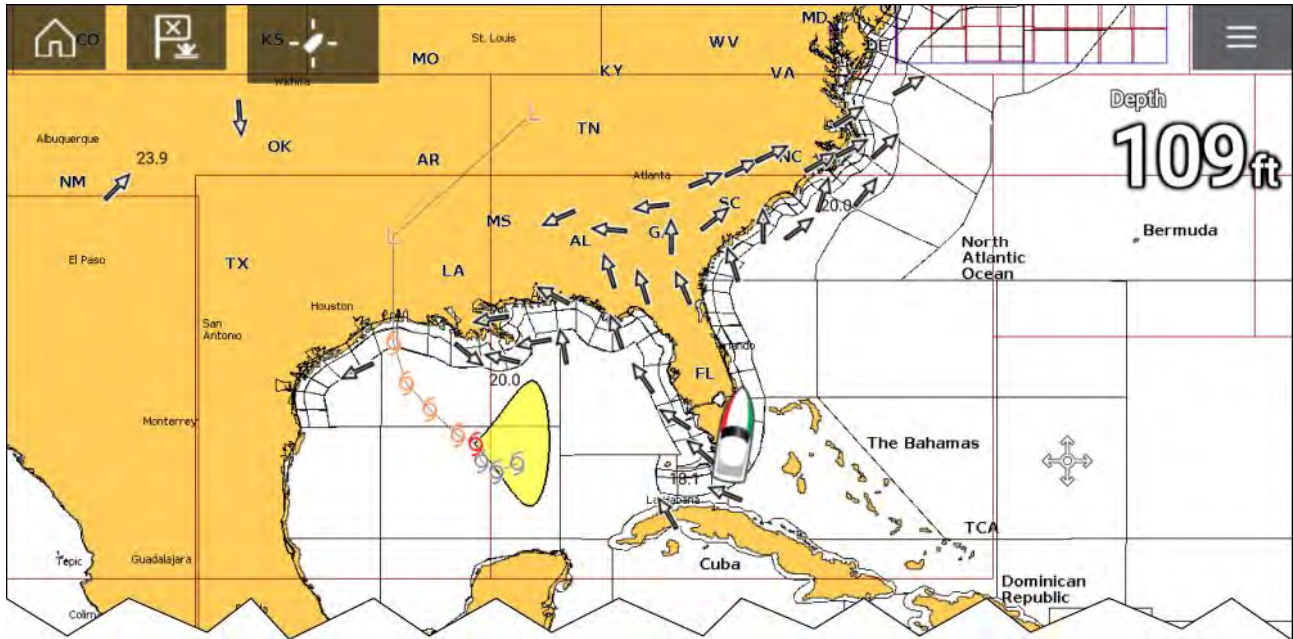

Storm tracks

Storm track symbols identify the type and time period of the storm.

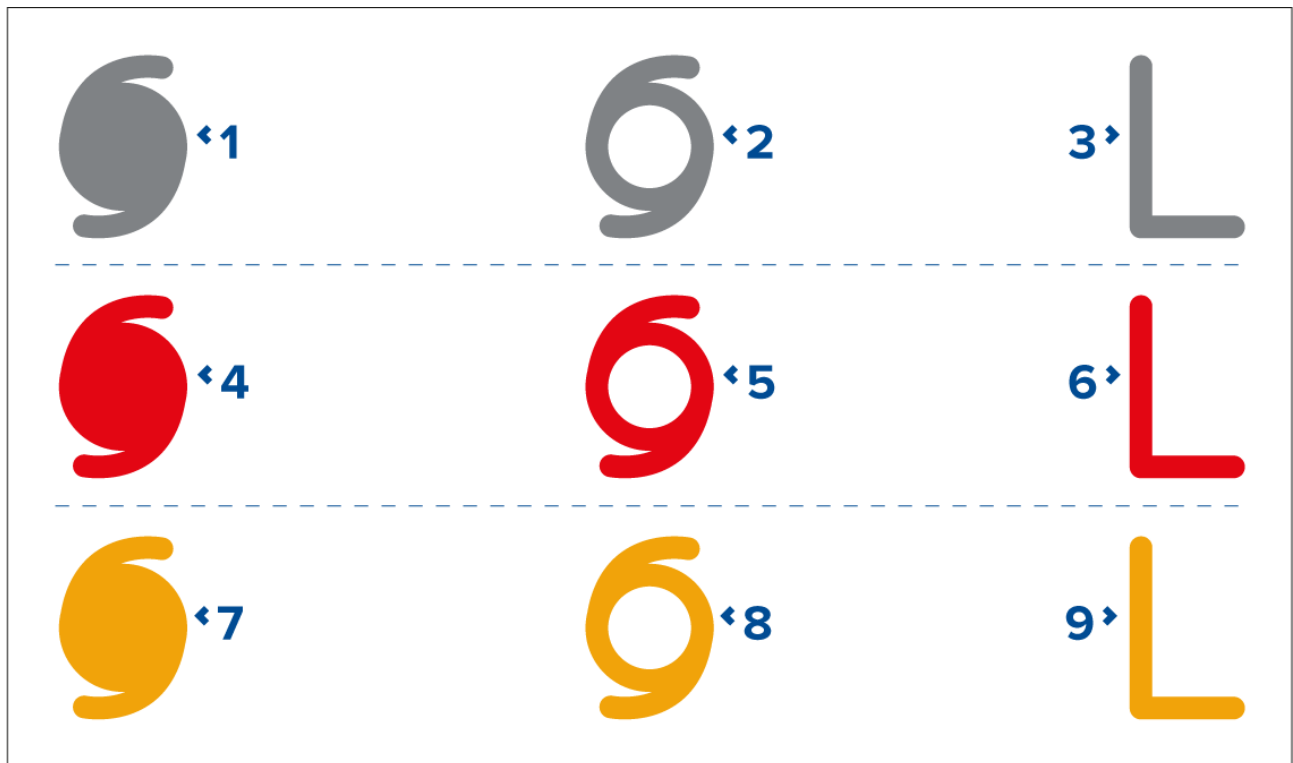

Item	Category	Color	Description
1, 2, 3	Historical	Grey	Hurricane (Category 1–5)
4, 5, 6	Current	Red	Tropical storm
7, 8, 9	Forecast	Orange	Tropical disturbance, tropical depression

Storm data is available from the context menu when a symbol is selected.

Surface wind fields (Wind Radii) are shown using colored shapes representing the wind field area and speed.

- **Pink** — wind speed = 64 knots or greater.
- **Orange** — wind speed = 50 knots or greater.
- **Yellow** — wind speed = 34 knots or greater.

9.9 Sea surface temperature and Surface pressure layers

The Sea surface temperature layer uses color coding to identify water temperature. The Surface pressure layer uses standard pressure patterns and Isobars to identify surface pressure.

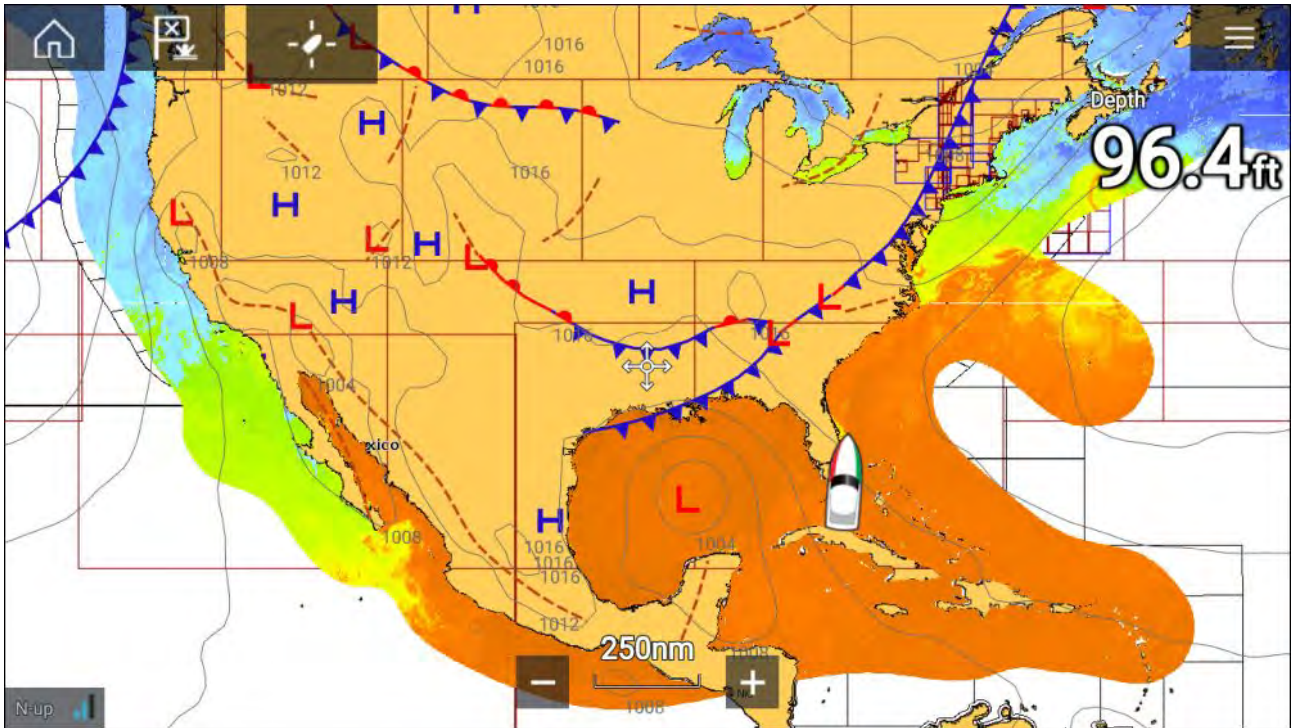





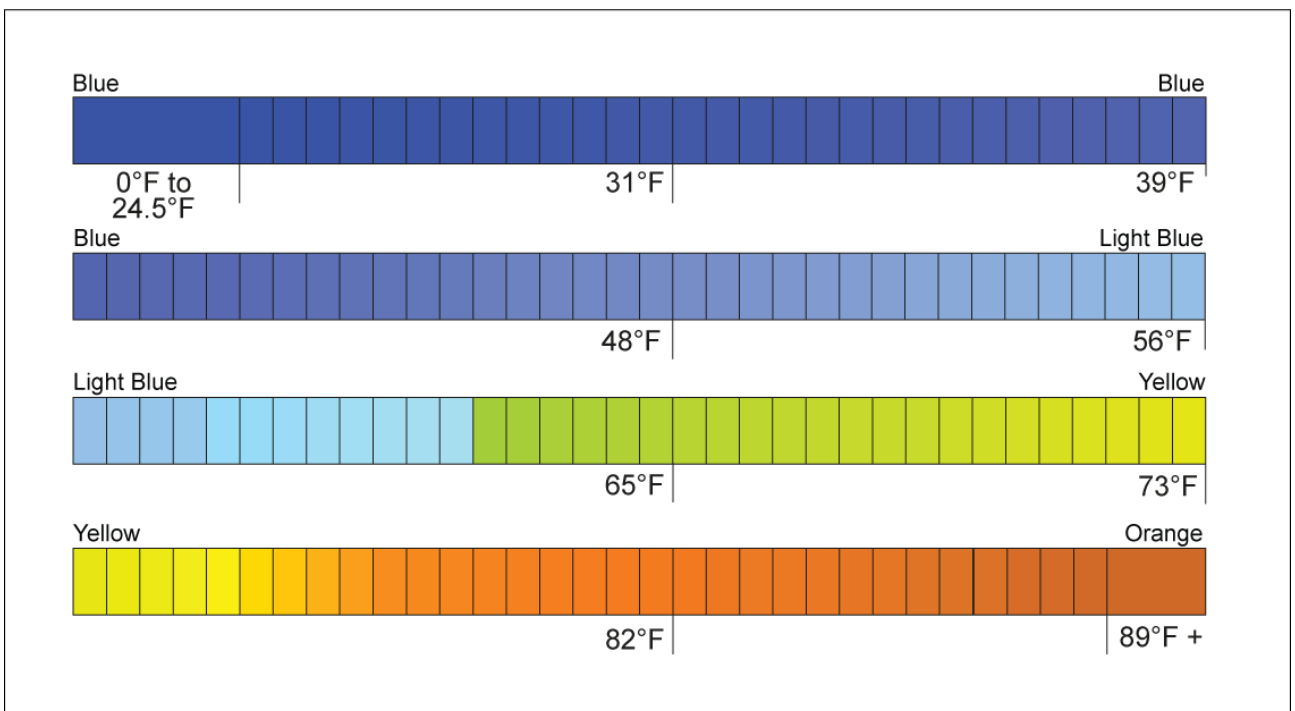



Sea surface temperature color coding

The colors used for the Sea surface temperature are shown below:



Surface pressure patterns

The Surface pressure layer uses standard meteorological patterns to represent surface pressure conditions.

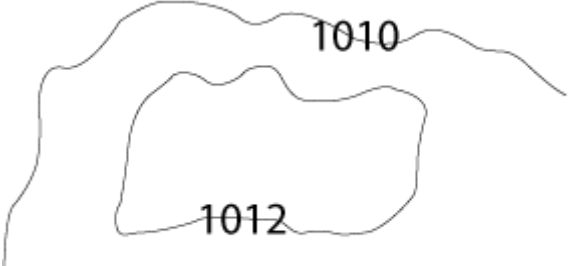
Symbol	Description
 <p>A diagram showing a high-pressure system on the left, represented by a red 'H' and a low-pressure system on the right, represented by a blue 'L'. Both are surrounded by curved lines representing isobars.</p>	High / low pressure (Blue and Red)
 <p>A red semi-circular line with semi-circles pointing towards the center of the curve.</p>	Warm front (Red)
 <p>A blue line with triangles pointing towards the center of the curve.</p>	Cold front (Blue)
 <p>A purple line with semi-circles on one side and triangles on the other, both pointing towards the center of the curve.</p>	Occluded front (Purple)
 <p>A blue line with triangles on one side and semi-circles on the other, both pointing towards the center of the curve.</p>	Stationary front (Red-Blue)
 <p>A dashed brown line forming a shallow curve.</p>	Trough (Brown)
 <p>A dashed red line with small squares along its length.</p>	Squall line (Red)
 <p>A red line with semi-circles along its length.</p>	Dry line (Red)
 <p>A diagram showing two irregular closed lines representing isobars. The inner line is labeled '1012' and the outer line is labeled '1010'.</p>	Isobars (Gray)

9.10 Wind and Watchbox layers

The Wind layer uses Arrows or Barbs to identify wind direction and speed. The Watchbox layer identifies areas where severe weather is occurring or forecast within a specified range.

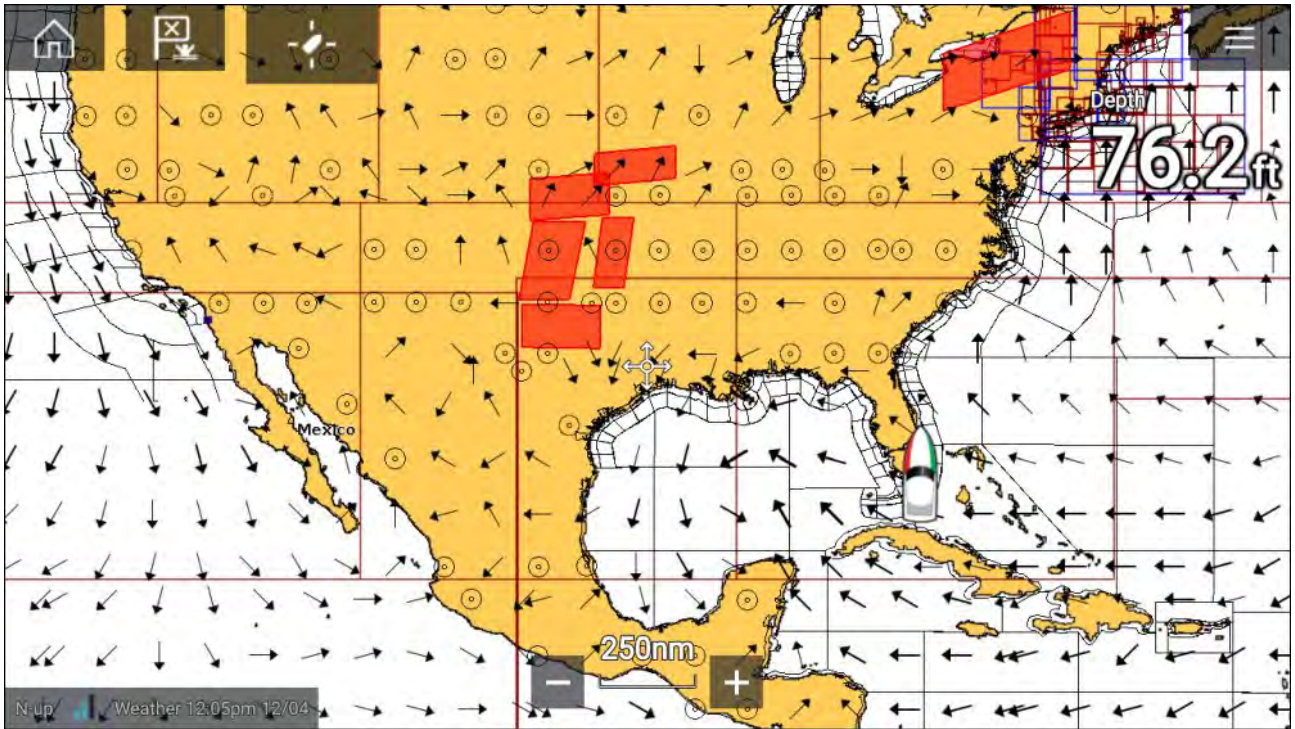

Wind arrows

The direction of the arrow indicates wind direction and the size of the arrow indicates wind speed, the larger the arrow the greater the wind speed. Where conditions are calm a circular symbol is used.

You can switch between using Arrows or Barbs for Wind data from the Weather tab of the Chart menu: **Menu > Settings > Weather > Wind symbol.**

Wind barbs

Wind barbs identify wind direction and speed.

Barbs provide a more accurate speed resolution than arrows.

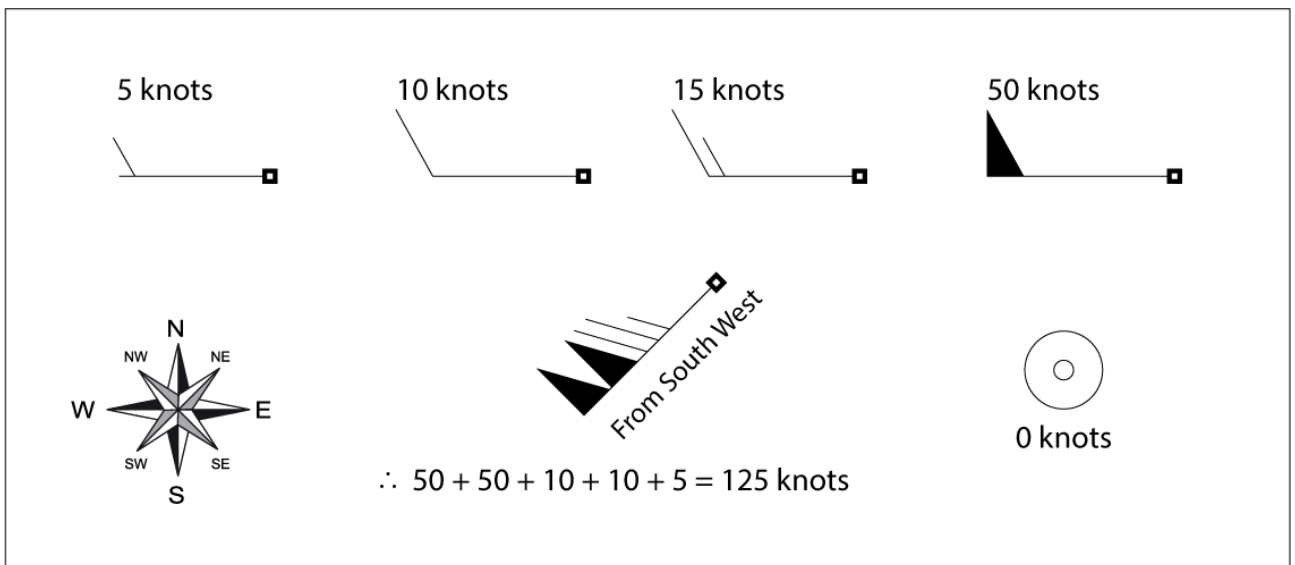

Adding the half barbs, full barbs and flags together provides wind speed. The direction the barbs point towards indicates where the wind is coming from.

- Half barbs = 5 knots
- Full barbs = 10 knots
- Flag = 50 knots

Watchbox

Selecting Watchbox data from the Weather context menu display the data associated with the Watchbox alert.

Watchbox alerts can be enabled and disabled from the Chart menu: **Menu > Settings > Weather > Watchbox alerts.**

You can also adjust the area that is monitored for Watchbox alerts using the **Watchbox range** control on the **Weather** tab.

9.11 Wave direction, height and period layers

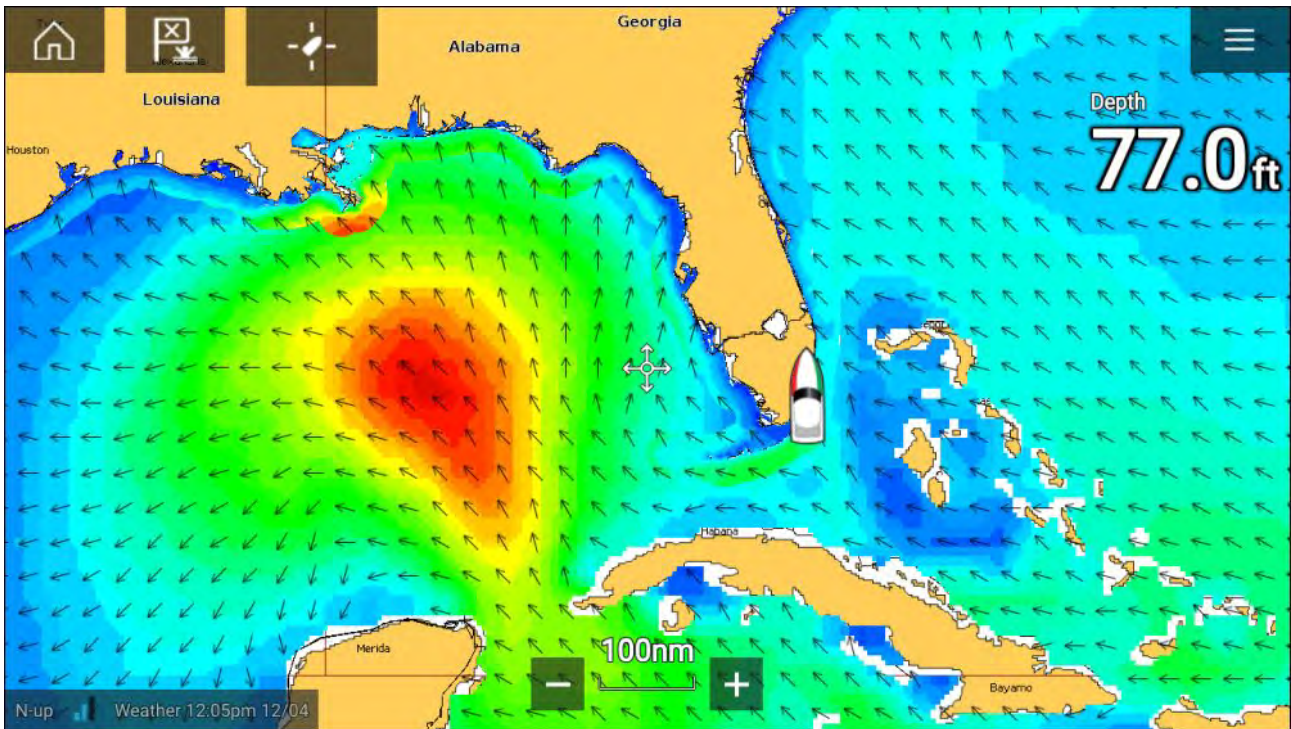

Wave direction

The **Wave direction** layer uses arrows to identify the direction of waves.

Wave height

Wave height uses colors to identify the height of waves. The colors used are as follows:

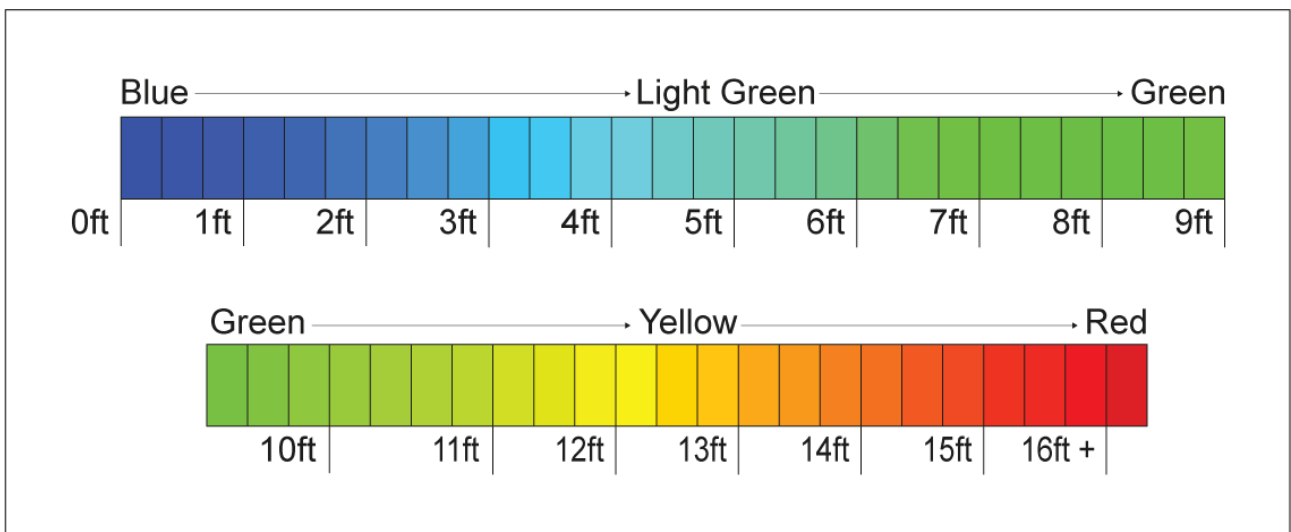

Wave period

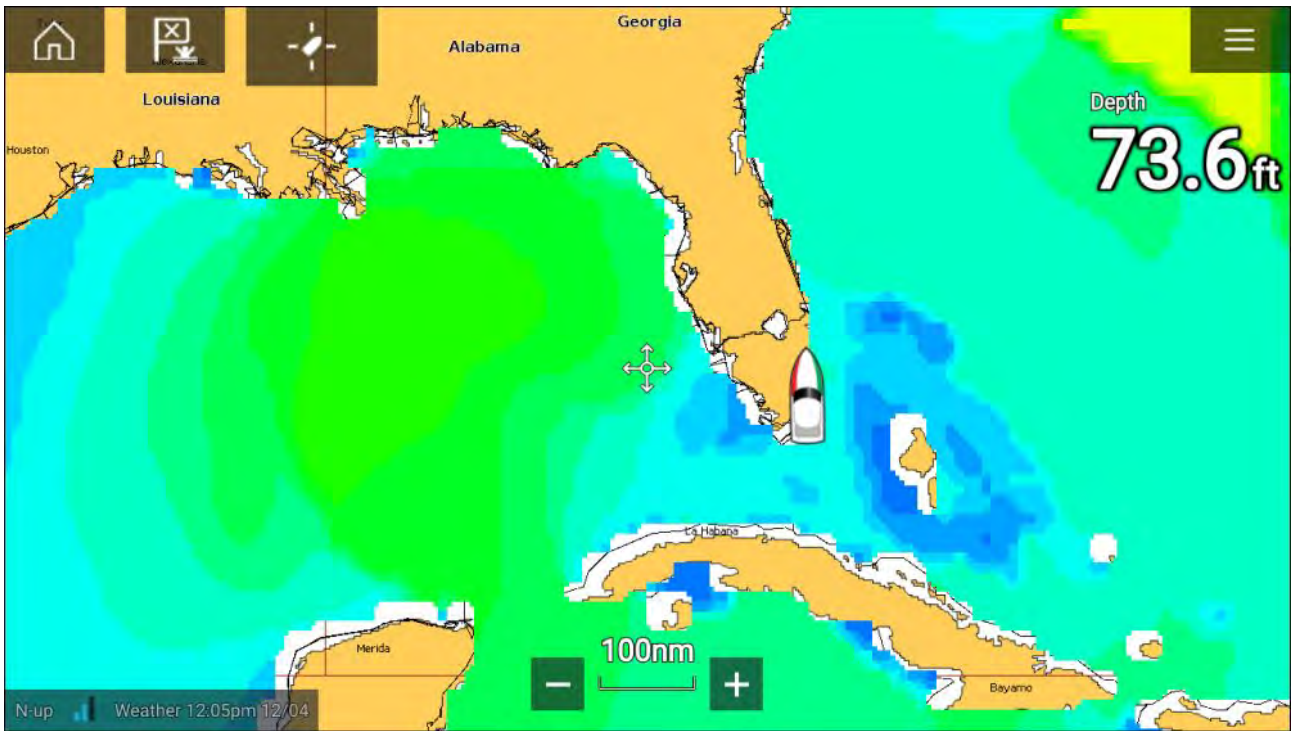

Wave period uses colors to identify the gap between successive waves. The colors used are as follows:

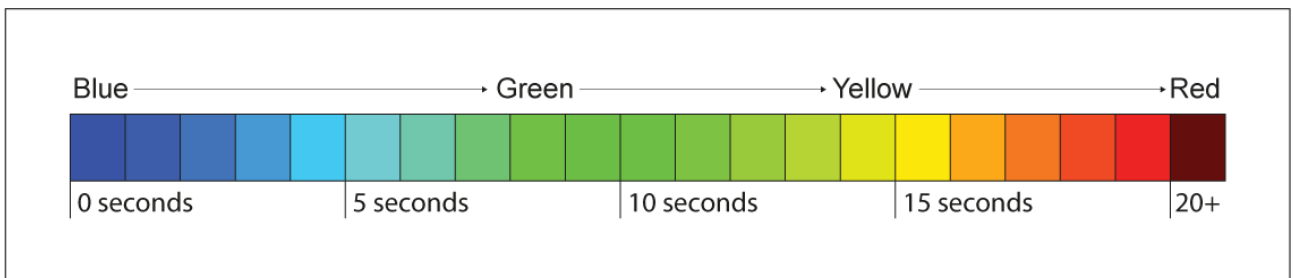

Chapter 10: Fishfinder app

Chapter contents

- 10.1 Fishfinder app overview on page 184
- 10.2 Opening the Fishfinder app on page 186
- 10.3 Sonar channels on page 188
- 10.4 Placing a Waypoint (Sonar, DownVision and SideVision) on page 189
- 10.5 Sonar scroll back on page 190
- 10.6 Sonar sensitivity controls on page 191
- 10.7 Fishfinder settings menu on page 192

10.1 Fishfinder app overview

The Fishfinder app displays a visualization of the echoes received from a Sonar module and transducer. The Fishfinder app is compatible with Traditional, CHIRP, DownVision™, SideVision™ and RealVision™ 3D sonar modules and transducers. The Fishfinder app builds an underwater view of bottom structure and targets in the water column.





Multiple Sonar modules can be connected at the same time. Sonar modules can be internal (built-in to your MFD) or external (a separate box on your network).

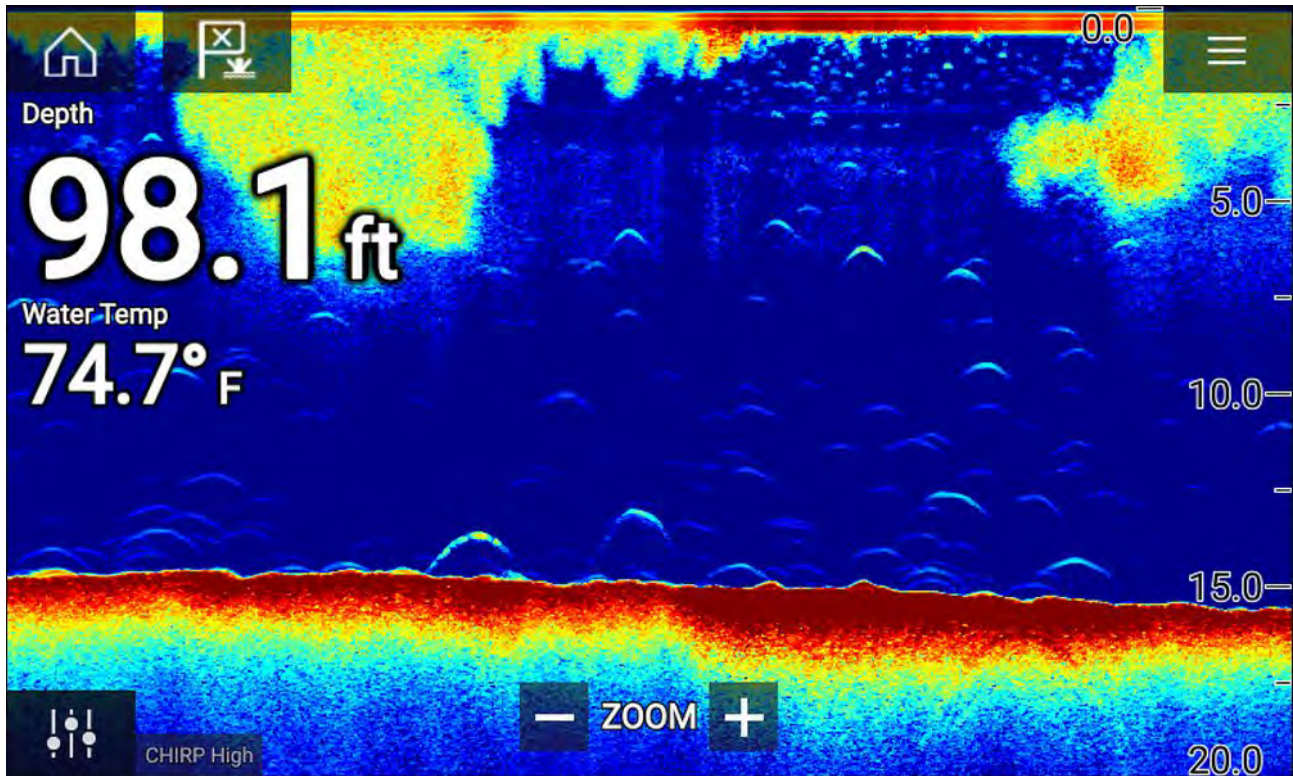



For each instance of the Fishfinder app you can select which Sonar module and channel that you want to use, the Sonar module and channel selection will persist over a power cycle.

The Fishfinder app can be displayed in both Fullscreen and splitscreen app pages. App pages may consist of up to 4 instances of the Fishfinder app.



Fishfinder app controls

Icon	Description	Action
	Home icon	Takes you to the Homescreen
	Waypoint / MOB	Place waypoint / activate Man overboard (MOB) alarm
	Pilot icon	Opens and closes the Pilot Sidebar
	Menu icon	Opens the app menu

Icon	Description	Action
	Image adjustment	Displays onscreen sensitivity / image adjustment controls
	Pause	Pause RealVision™ 3D sonar image.
	Unpause	When the Fishfinder app is paused, you can recommence scrolling by selecting the Unpause icon.
	Range/Zoom In	When Auto range is enabled, pressing the plus icon activates Zoom mode, subsequent presses will increase the Zoom factor. When Range is set to Manual pressing the Plus icon decreases the distance displayed onscreen. Auto range can be enabled and disabled from the Menu: Menu > Auto range.
	Range/Zoom Out	When in Zoom mode, pressing the minus icon will decrease the Zoom factor and finally revert to normal mode. When Range is set to Manual pressing the Minus icon increases the distance displayed onscreen.

Touchscreen controls

- Pinch-to-zoom changes the magnification of the image.
- The Range control determines how far the sonar will ping.
- Press and hold onscreen to display the context menu

RealVision 3D controls

When using RealVision 3D sonar you can manipulate the view using touch gestures.

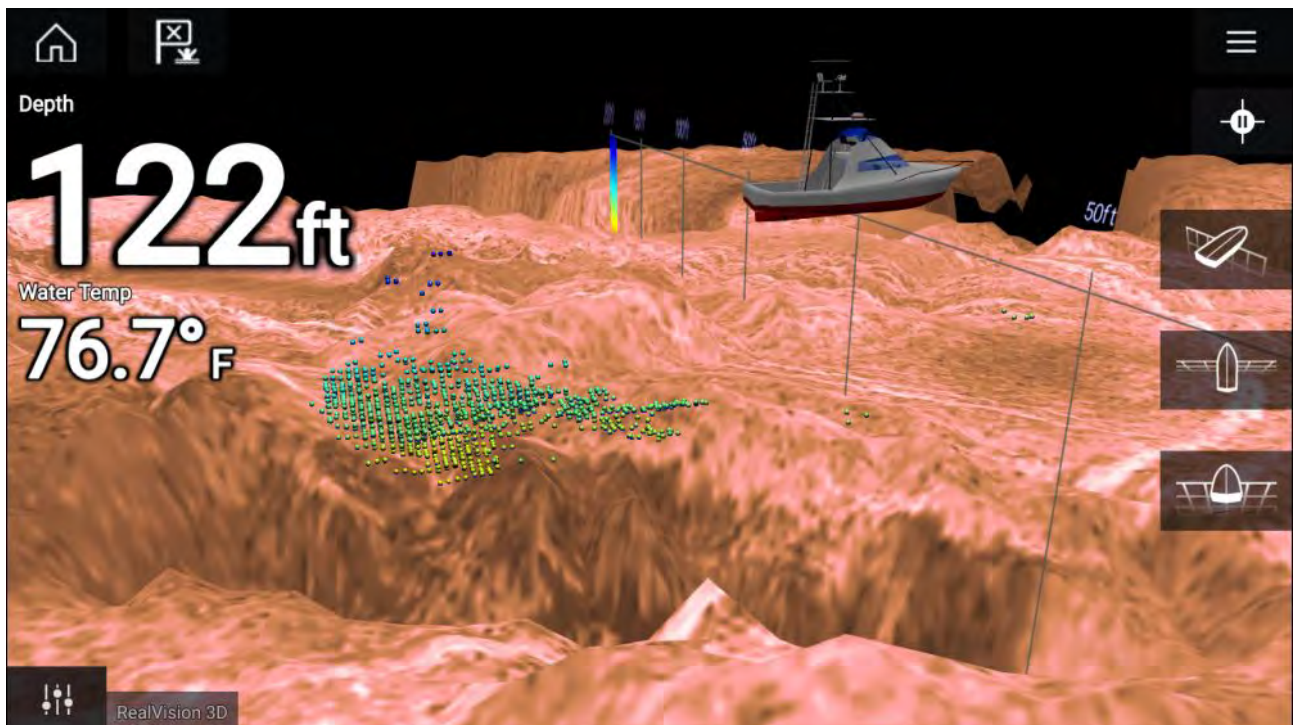

Touchscreen controls

- One finger swipe rotates the image.
- Two finger swipe pans the image around the screen.
- Pinch-to-zoom changes the magnification of the image.
- The Range control determines how far the sonar will ping.
- Press and hold onscreen to display the context menu

Physical buttons

- **Ok** button pauses Sonar scrolling.
- **Back** button resumes Sonar scrolling.
- **Ok** button when paused opens the context menu.
- Use the Uni-controller's **Directional** (Up, Down, Left, Right) controls to rotate the image.
- Use the Uni-controller's **Rotary** control or a RMK's **Range In** and **Range Out** buttons to Range in and out.

10.2 Opening the Fishfinder app

The Fishfinder app is opened by selecting a page icon from the Homescreen that includes a Fishfinder app.

Pre-requisites:

1. Ensure your Sonar module is compatible (check the latest details available on the Raymarine website). If in doubt contact an authorized Raymarine dealer for advice.
2. Ensure you have installed your Sonar module in accordance with the documentation that was supplied with the module.

The Fishfinder app will open in 1 of 4 states:

Please select a sonar channel

The first time you open a new app page that includes the Fishfinder app you will need to select a Sonar channel.

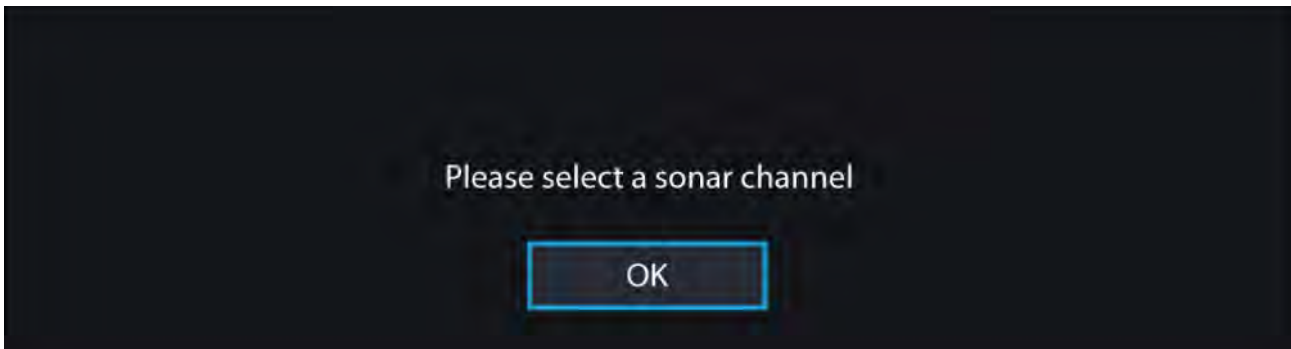

Select **OK** and then choose the Sonar channel you want to use from the list:

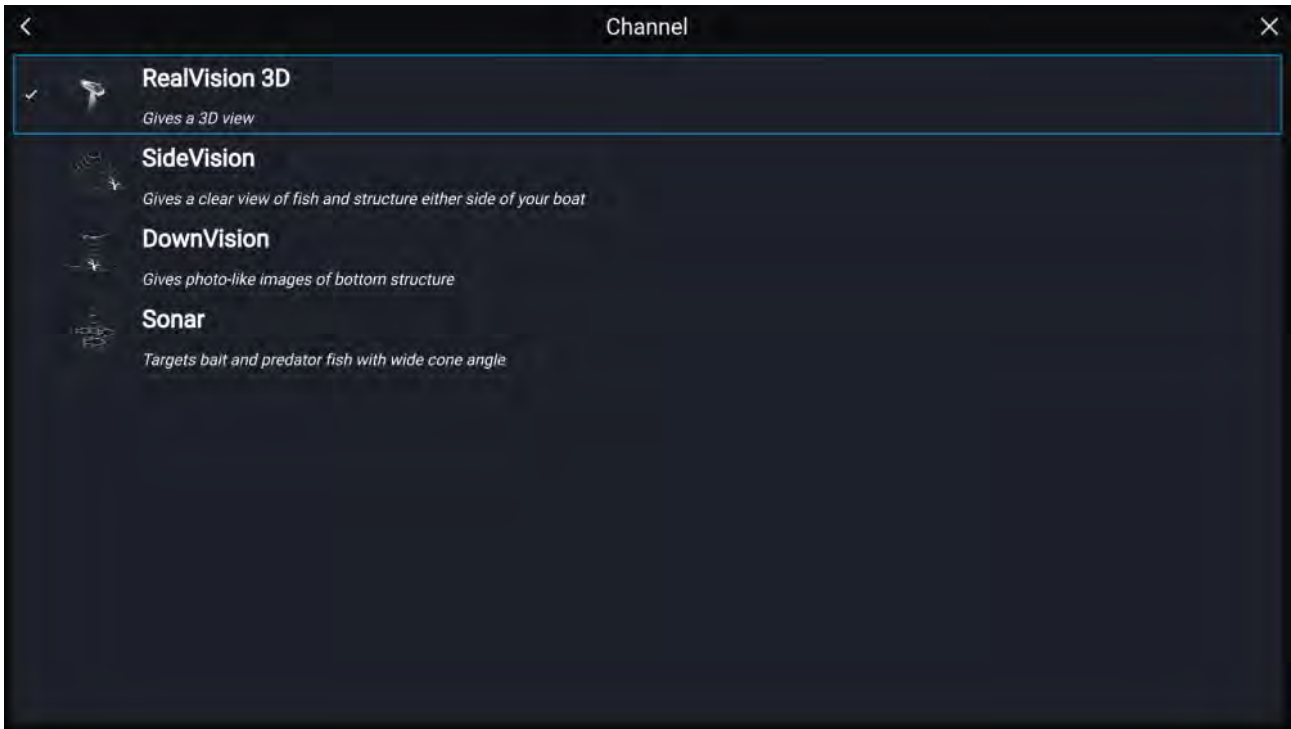

Sonar on and pinging

If your Fishfinder app has already been set up then when the Fishfinder app is opened the Sonar image will be displayed and start scrolling.

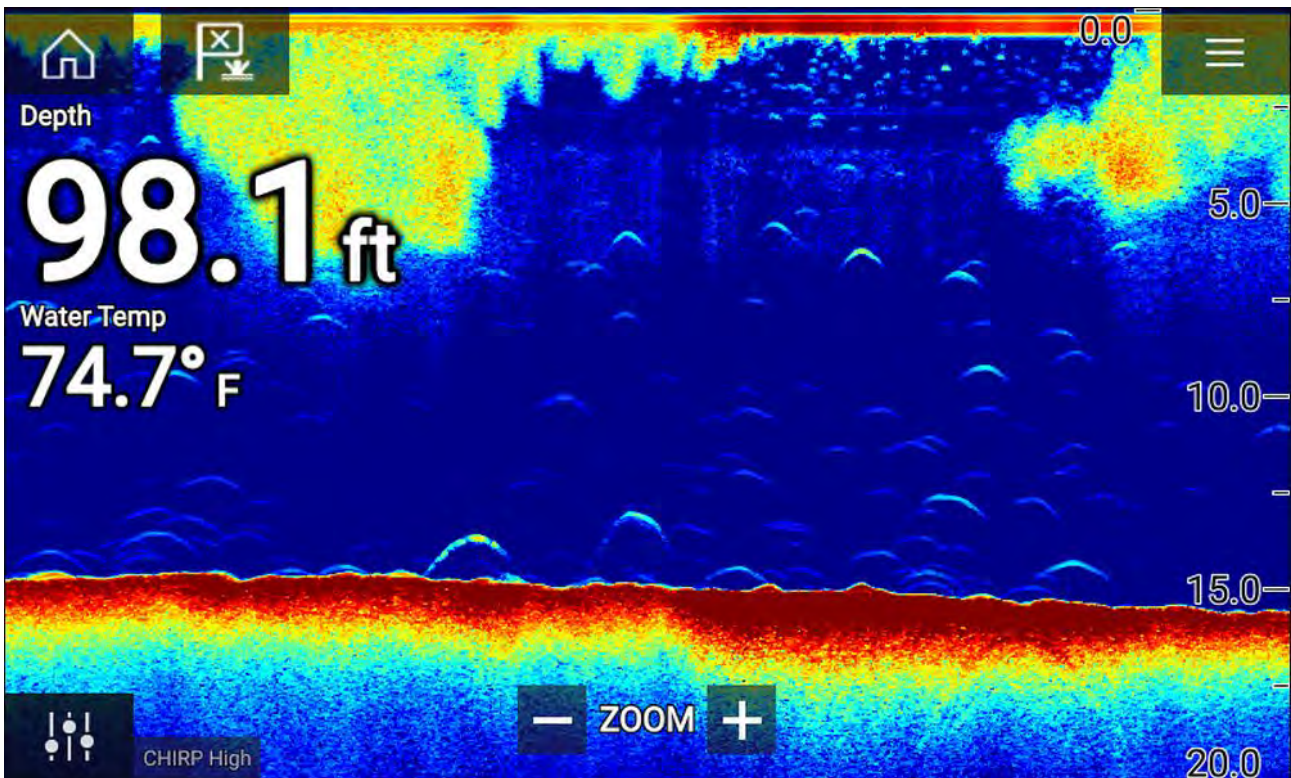

No sonar source available

If the 'No sonar source available' warning is displayed then either:

- your sonar module is still powering up.
- your MFD cannot establish a connection with your external Sonar module
- your Internal Sonar module has no transducer connected.

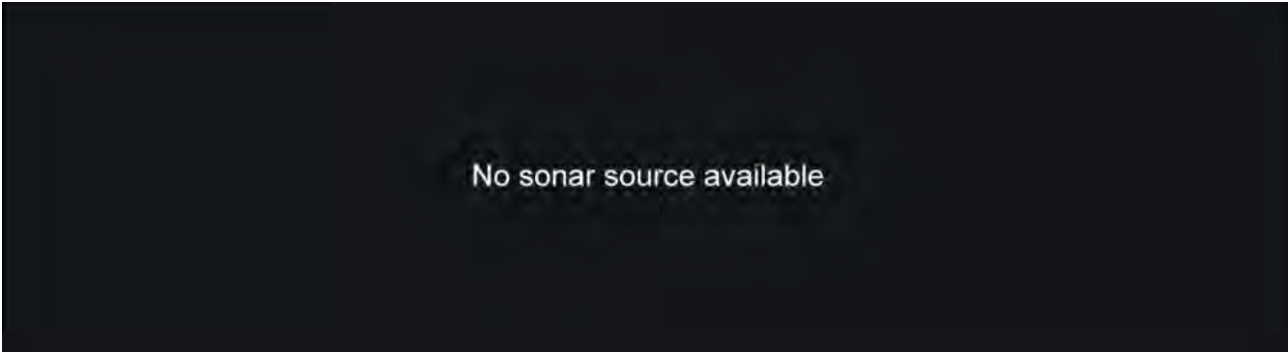

Check your external sonar module's network and power connection, check your MFD's network or transducer connection ensuring the connections and cabling is correct and free from damage, then power cycle your system. If the Sonar module is still not found then refer to your equipment's installation documentation for further troubleshooting information.

No transducer connected

If the '**No transducer connected**' warning is displayed then your Sonar module cannot connect to your transducer.

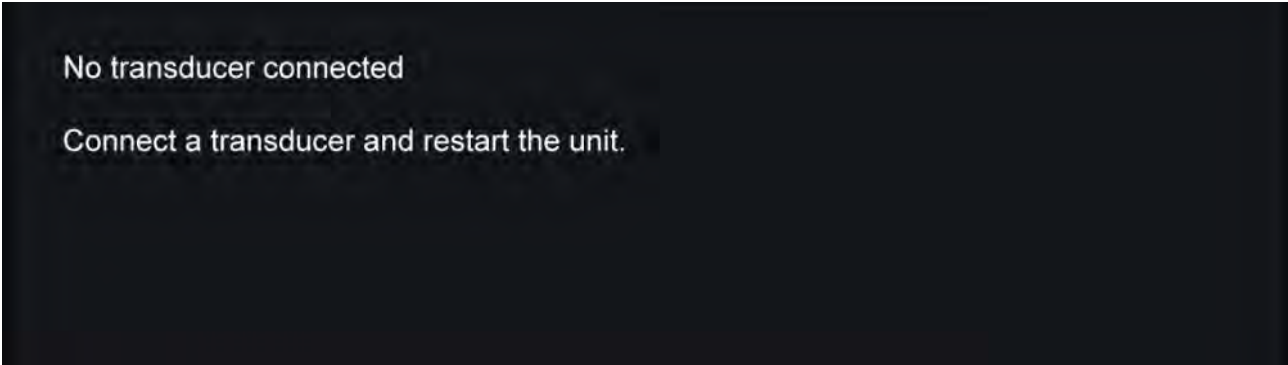

Check your transducer connection(s) are correct and free from damage, then power cycle your system. If the transducer is still not found then refer to your equipment's installation documentation for further troubleshooting information.

10.3 Sonar channels

The Sonar channels that are available depend on the Sonar module and transducer you have connected.



RealVision™ 3D



SideVision™

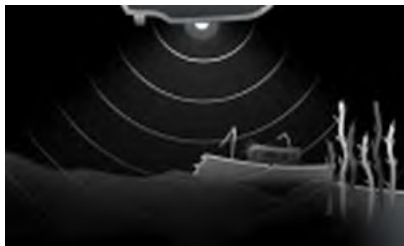

DownVision™



High CHIRP / High Frequency



Medium CHIRP / Medium Frequency



Low CHIRP / Low Frequency

Selecting a Sonar channel

The first time you open a new Fishfinder app page you will be requested to select a channel, subsequently you can change the sonar channel by selecting a channel icon from the Fishfinder app menu.

1. Select a relevant channel icon from the Menu.
2. Alternatively select **All channels** from the Menu and then choose your desired sonar module and channel.

10.4 Placing a Waypoint (Sonar, DownVision and SideVision)

When you observe something of interest in the Fishfinder app you can place a waypoint at its location so that you can find the area again.

1. Select and hold on the point of interest onscreen.
The Context menu is displayed and scrolling is paused, temporarily.
2. Select **Add Waypoint** from the context menu.

The Sonar image will remain paused for approximately 10 seconds after the Waypoint has been placed.

Placing a waypoint RealVision 3D

To place a waypoint whilst viewing a RealVision 3D channel follow the steps below.

1. Select and hold a location onscreen.
The Waypoint context menu and Red waypoint marker is displayed:

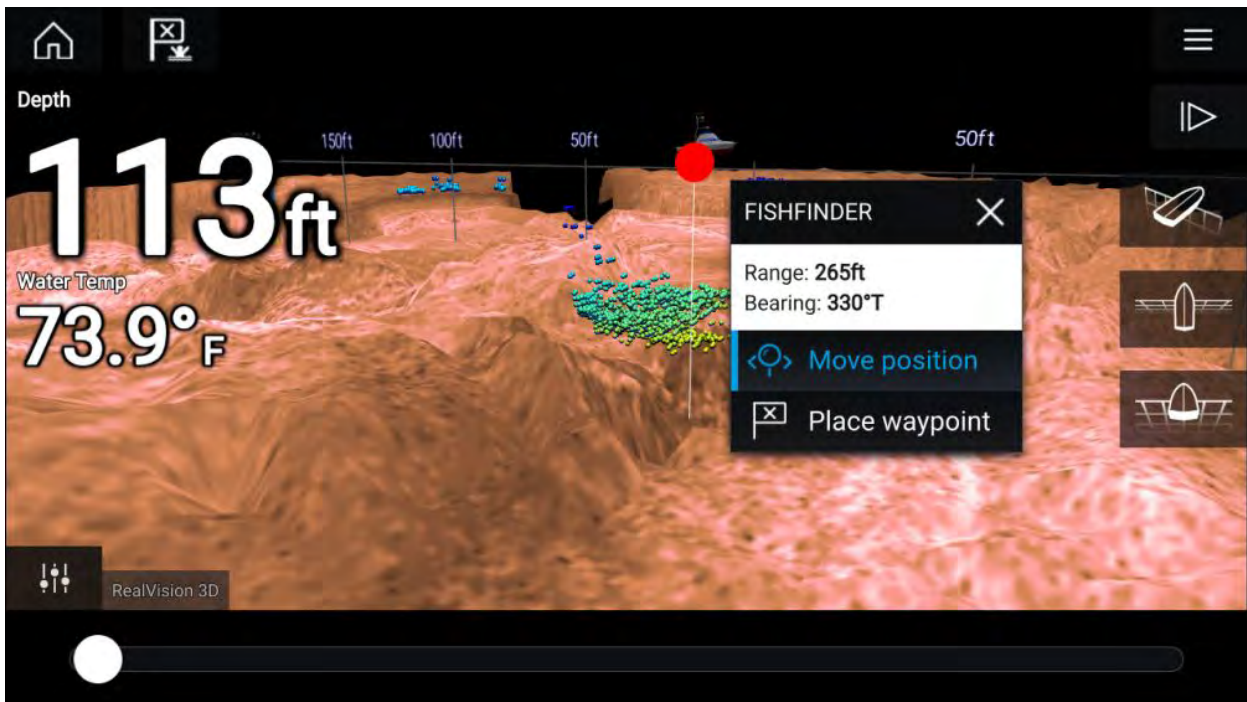

2. Select **Place waypoint** to create a waypoint at the marker's location, or

3. Select **Move position** to adjust the marker's position before creating the waypoint.



You can move the waypoint along its current axis by sliding 1 finger across the screen. You can also adjust the view onscreen using the usual 2 finger touch gestures.

4. When the marker is over the desired location select **Place waypoint** to save a waypoint at the marker's location.

10.5 Sonar scroll back

You can “scroll back” in the Fishfinder app to view sonar history.

To activate sonar “scroll back”, perform the following:

- **Sonar and DownVision** — Swipe your finger left to right across the sonar screen.
- **SideVision** — Swipe your finger from the bottom to the top of the sonar screen.
- **RealVision 3D** — Select the onscreen **Pause** icon.

When sonar scroll back is active the sonar **Scroll back bar** and **Unpause** icons are displayed.

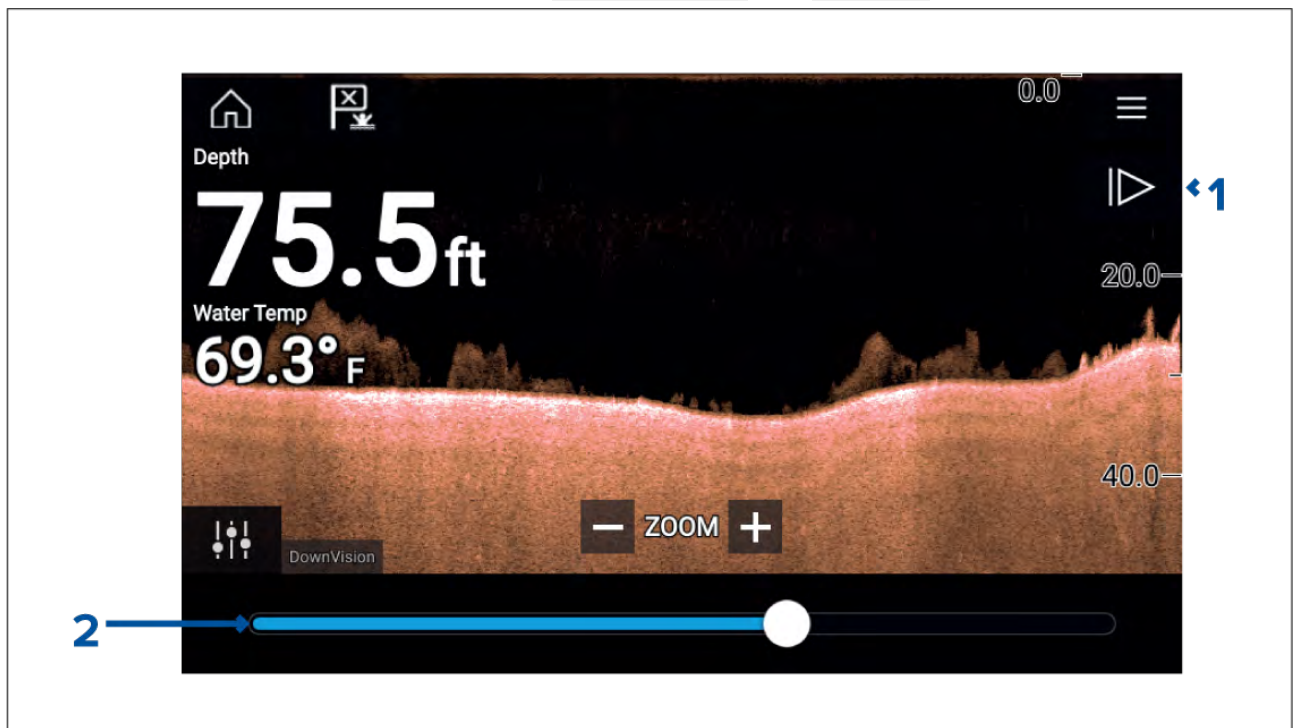

1. **Unpause** — Selecting this option resumes live sonar scrolling.
2. **Scroll back bar** — Use this to move back and forward through the available sonar history. You can either drag the position indicator right or left or select a specific location on the bar to jump to that position.

In Sonar, DownVision and SideVision channels, subsequent swipes will rewind the sonar history and swiping in the opposite direction will fast forward the sonar history.



10.6 Sonar sensitivity controls



Optimum performance is usually achieved using the default settings. You can adjust the image using the Sensitivity controls to improve the displayed image. Sensitivity setting adjustment is also applied to the sonar history that is displayed when using sonar scroll back.



Sensitivity settings can be accessed using the onscreen **Image adjustment** icon, or the Adjust sensitivity menu option: **Menu > Adjust sensitivity**.

The Sensitivity controls available are dependant upon the Sonar module in use.

Control	Name	Description
	'G' Gain	The control determines the signal strength at which target returns are shown onscreen. The Gain control can be set to Auto or Manual . Depending on Sonar module, in Auto you can add an offset of up to $\pm 50\%$. A higher value produces more target returns and noise onscreen.
	'I' Intensity, or 'CG' Color Gain	The control sets the lower limit for the color used for the strongest target returns. All target returns above this value are displayed in the strongest color. Those with a weaker value are divided equally between the remaining colors. The control can be set to Auto or Manual . Depending on Sonar module, in Auto you can add an offset of up to $\pm 50\%$.
	'SF' Surface Filter , or 'NF' Noise filter	The control determines the amount of noise displayed onscreen by varying the gain throughout the water column. A lower value decreases the depth at which the control is applied. The control can be set to Auto or Manual .

Control	Name	Description
	'TVG' Time Varied Gain	The control determines the amount of attenuation applied throughout the water column to ensure that targets of a similar size appear the same regardless of depth. A higher value produces weaker targets and less noise onscreen. The control can be set to 1 of 3 Auto modes or can be set to Manual .
	All to Auto	Sets all Sensitivity settings to Auto with 0% offset.

10.7 Fishfinder settings menu

The table below lists settings applicable to the Fishfinder app and their location within the app Settings menu. The settings available are dependant upon the Sonar module in use.

Sonar display tab

Settings	Description	Options
Color palette	Various color palettes are available to suit different conditions or your personal preference.	List of color palettes.
View selection buttons	Enables and disables SideVision™ Left, Right and Both onscreen channel selection icons.	<ul style="list-style-type: none"> • On • Off
A-scope	A-Scope mode provides a splitscreen view that includes the normal scrolling sonar image and a smaller pane which shows a 'live' image of what is directly below your transducer.	<ul style="list-style-type: none"> • Off • Center • Right • Cone
Bottom lock	Bottom lock flips the range indication so that the bottom always appears flat.	<ul style="list-style-type: none"> • On • Off
Range lines	Displays vertical range lines when viewing.	<ul style="list-style-type: none"> • On • Off
Depth lines	Displays horizontal depth lines.	<ul style="list-style-type: none"> • On • Off
White line	Displays a solid white line along the bottom contour.	<ul style="list-style-type: none"> • On • Off
Bottom fill	Displays a solid color fill for the bottom.	<ul style="list-style-type: none"> • On • Off
Color threshold	Color threshold determines the signal strength below which target returns are not shown. A low value results in only the strongest colors or lightest shades being displayed.	• 0% to 100%
Scroll speed	Determines the scrolling speed for the Sonar image.	• 10% to 500%

RealVision™ 3D — Sonar display tab

Settings	Description	Options
Boat icon	Choose which boat icon to use.	List of available Boat icons.
Image stabilization	Uses RealVision™ 3D transducer's built-in sensors to counter-act the rocking motion of your vessel to produce a stable sonar image.	<ul style="list-style-type: none"> • On • Off
Target colors	Changes the color palette used for target returns.	List of color palettes.
Color targets by	Changes the way targets are colored. Depth colors targets according to their depth, a gradient scale can be shown on the 3D grid to aid depth identification. Intensity colors targets according to their size, the bigger the target the darker the color used.	<ul style="list-style-type: none"> • Depth • Intensity
Show targets as	Changes the method of rendering targets, Point provides the highest resolution, Sphere provides a lower resolution but increases target size for increased visibility.	<ul style="list-style-type: none"> • Point • Sphere
Bottom colors	Changes the color used for bottom structure.	List of colors.
Background	Changes the color used for the app background.	List of colors.
View mode	In GPS track mode the boat icon will remain in the same position and bottom structure and target detail will move in true relation to your vessel movements. In Scrolling image mode the sonar pings at a constant speed and displays a scrolling image behind the boat icon.	<ul style="list-style-type: none"> • GPS track • Scrolling image

Transducer tab

Settings	Description	Options
Transducer	Allows selection of Sonar transducer.	List of available transducers.
Display depth as	Determines the position from where depth readings are taken from.	<ul style="list-style-type: none"> • Below keel • Below waterline • Below transducer
Speed transducer	Allows selection of Speed transducer.	List of available transducers.
Calibrate speed	Allows you to enter an offset between actual measured speed and the current speed displayed by your transducer.	Offset value.
Enable temperature sensor	Enables and disables the selected transducer's temperature sensor.	<ul style="list-style-type: none"> • On • Off
Calibrate temp	Allows you to enter an offset between actual measured water temperature and the current temperature displayed by your transducer.	Offset value.

Sounder tab

Settings	Description	Options
Sounder name	Allows you to rename your sonar module.	Onscreen keyboard.
Ping enable	Enables and disables transducer ping.	<ul style="list-style-type: none"> • On • Off

Settings	Description	Options
Ping rate limit	Allows you to restrict the transducer's maximum ping rate to suit current conditions.	<ul style="list-style-type: none"> • 1 to 100
Power mode	Adjusts the transducer's signal strength. In Auto the sonar module will automatically determine the optimal power based on current depth, speed and bottom signal. In Manual you can adjust the power to the desired level.	<ul style="list-style-type: none"> • 1 to 100
Ping rate	Hyper ping should be used at speeds of up to 40 knots in shallower waters (6 metres or less). When the depth reaches 6 metres or above the ping rate will automatically reduce to normal until depth conditions are met.	<ul style="list-style-type: none"> • Normal • Hyper
Dual channel ping mode	On sonar modules that offer simultaneous dual channel operation, such as the CP570, The ping mode can be changed. Auto the Fishfinder app will select the best mode chosen based on range settings. Independent pings maximizes ping rate but may introduce interference. Simultaneous pings reduced ping rate and reduces chance of interference.	<ul style="list-style-type: none"> • Auto • Independent pings • Simultaneous pings
Tune frequency	Enables manual tuning of non-CHIRP frequency channels.	<ul style="list-style-type: none"> • -50% to +50%
AHRS stabilization	The AHRS built in to the RealVision™ 3D transducer is used to stabilize the sonar image onscreen based on your vessel's detected movements.	<ul style="list-style-type: none"> • On • Off
Reverse Port/Starboard	When a RV100 transducer is hull/step mounted the transducer can be installed with the cable orientated towards either the bow or the stern of the vessel. On installations where the transducer cable is orientated towards the stern of the vessel then the Reverse Port/Starboard control must be enabled.	<ul style="list-style-type: none"> • Enabled • Disabled
Interference rejection	Removes interference caused by other transducers on your vessel or from vessels equipped with transducers close by.	<ul style="list-style-type: none"> • Auto • Low • Medium • High • Off
2nd echo rejection	The control helps to remove false target returns or false bottom that can be caused by signal reflection.	<ul style="list-style-type: none"> • Off • Low • High
Reset sounder	Resets the sonar module to factory default settings.	<ul style="list-style-type: none"> • Yes • No
Reset trip	In installations that include a speed transducer connected via the sonar module a trip log is automatically recorded. Selecting this option resets the sonar module's trip log.	<ul style="list-style-type: none"> • Yes • No

Page settings tab

Settings	Description
Data Overlays	Enables configuration of Data overlays, which overlay key information from connected sensors onto the Chart, Radar, Sonar and Camera apps.
Edit split ratio	Enables you to customize the position of the partitions in splitscreen app pages. For example, 50/50, 70/30 etc.

Chapter 11: Radar app

Chapter contents

- [11.1 Radar app overview on page 198](#)
- [11.2 Radar feature comparison on page 200](#)
- [11.3 Opening the Radar app on page 203](#)
- [11.4 Set up on page 205](#)
- [11.5 Radar modes on page 206](#)
- [11.6 Range and bearing on page 208](#)
- [11.7 AIS targets on page 210](#)
- [11.8 Radar targets on page 214](#)
- [11.9 Dangerous targets alarm on page 221](#)
- [11.10 Guard zone alarms on page 222](#)
- [11.11 Doppler Radar overview on page 223](#)
- [11.12 Blank sectors on page 224](#)
- [11.13 Radar sensitivity controls on page 225](#)
- [11.14 Radar settings on page 226](#)

11.1 Radar app overview

The Radar app displays a visualization of the echoes received from a connected Radar scanner. The Radar app is a navigation aid used to help enhance collision and situational awareness by enabling target's distance and speed to be tracked in relation to your vessel.

Up to 2 Radar scanners can be connected at the same time. However, only 1 Radar in a system can be a Quantum™ Radar.

For each instance of the Radar app you can select which Radar scanner you want to use, the Radar scanner selection will persist over a power cycle.

The Radar app can be displayed in both Fullscreen and splitscreen app pages. App pages may consist of up to 2 instances of the Radar app.

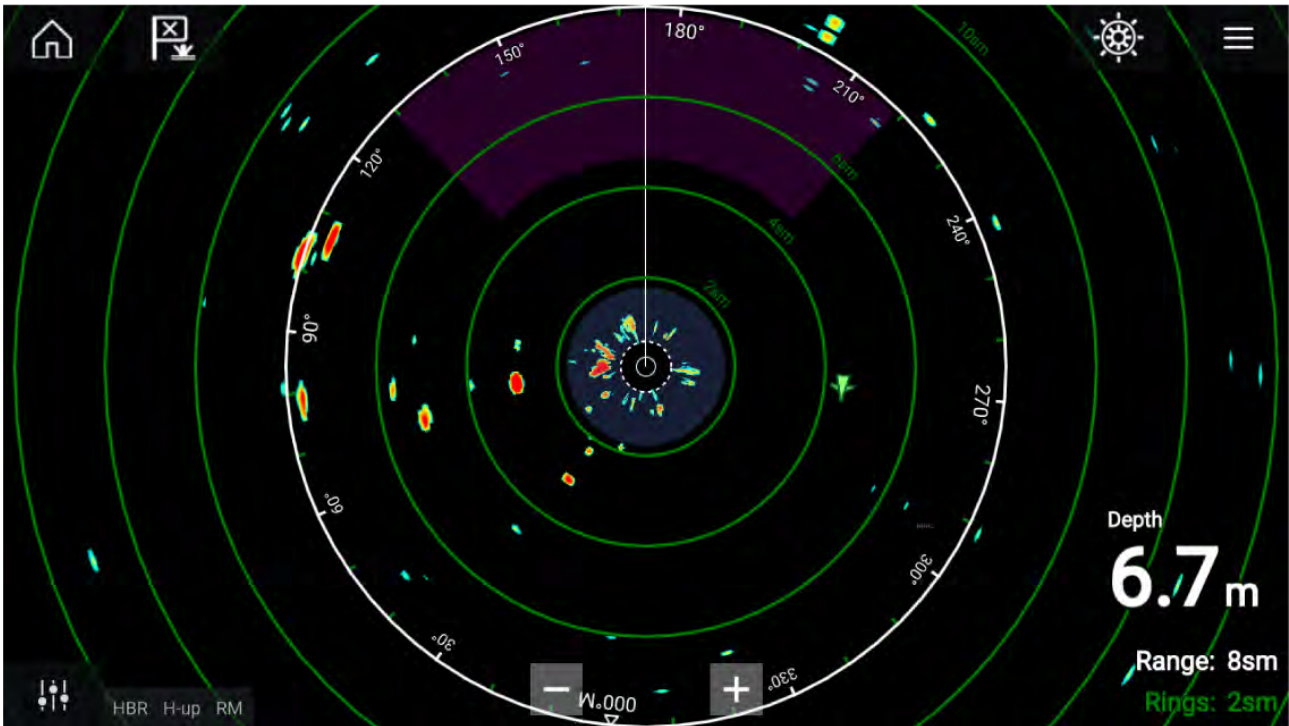











Tracked Radar targets and AIS targets are displayed using target symbols.

The Radar app allows you to configure alarms which are triggered when a target or object conflicts with the **Dangerous targets** or **Guard Zone** alarm settings.

The Range rings, bearing ring and VRM/EBLs can be used to identify a targets distance and heading in relation to your vessel.

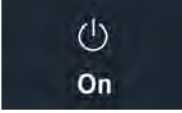
Radar app controls

Icon	Description	Action
	Home icon	Takes you to the Homescreen
	Waypoint / MOB	Place waypoint / activate Man Overboard (MOB) alarm
	Pilot icon	Opens and closes the Pilot Sidebar

Icon	Description	Action
	Menu icon	Opens the App menu
	Image adjustment	Displays onscreen sensitivity / image adjustment controls
	Power Off	Powers down the current Radar scanner
	Power On	Powers up the selected Radar scanner
	Transmit	Start Radar transmission
	Range In	Decreases the distance displayed onscreen (minimum range: 1/16nm).
	Range Out	Increases the distance displayed onscreen (up to your Radar scanner's maximum range).

Radar app context menu

Context menus provide context sensitive menu options.



- Context menus are accessed in the Radar app by selecting a location or target.
- The context menu provides Latitude, longitude, range and bearing details for the selected location or object.
- The context menu provides quick access to relevant settings or features.
- Select **More options** to display further options.

Camera tracking

When connected to a compatible Pan and Tilt Thermal camera you can track targets or point your camera at a specific target or area.

2 options are available for camera tracking:

- **Point camera here** — Points the camera at a specific point onscreen, the camera will remain pointed at this area regardless of your own vessel's course.
- **Track with camera** — Tracks a selected target regardless of your own vessel's or target's course.

Camera tracking options are available from the Context menu in the Chart and Radar apps: **Context menu > more options > Point camera here**, or **Context menu > more options > Track with camera**.

Automatic tracking

You can use the Camera app settings to configure automatic tracking for AIS, Radar and MoB targets: **Camera app > Menu > Settings > Camera motion > AUTO TRACKING**

11.2 Radar feature comparison

The range of features and settings that are available in the Radar app is dependent on the type of connected Radar scanner.

Sensitivity controls

Features/settings	Radar type
Gain	<ul style="list-style-type: none"> • All
Color Gain	<ul style="list-style-type: none"> • Magnum Open Array • Quantum™ 2 Doppler • Quantum™ • SuperHD™ Open Array • HD Open Array • HD Radome
Rain	<ul style="list-style-type: none"> • All
Sea Clutter	<ul style="list-style-type: none"> • All
FTC (Fast Time Constant)	<ul style="list-style-type: none"> • Digital Radome
Power Boost	<ul style="list-style-type: none"> • Magnum Open Array • SuperHD™ Open Array
Antenna Boost	<ul style="list-style-type: none"> • Magnum Open Array • SuperHD™ Open Array

Gain Modes

Features/settings	Radar type
Buoy	<ul style="list-style-type: none"> • Magnum Open Array • SuperHD™ Open Array • HD Open Array • HD Radome
Harbor	<ul style="list-style-type: none"> • All
Coastal	<ul style="list-style-type: none"> • All
Offshore	<ul style="list-style-type: none"> • All

Features/settings	Radar type
Bird	<ul style="list-style-type: none"> • Magnum Open Array • SuperHD™ Open Array • HD Open Array • HD Radome
Weather	<ul style="list-style-type: none"> • Quantum™ 2 Doppler • Quantum™

Features

Features/settings	Radar type
Doppler	<ul style="list-style-type: none"> • Quantum™ 2 Doppler
Dual Range	<ul style="list-style-type: none"> • Magnum Open Array • SuperHD™ Open Array • HD Open Array • HD Radome
Interference Rejection	<ul style="list-style-type: none"> • All
Interference Rejection Level	<ul style="list-style-type: none"> • Quantum™ 2 Doppler • Quantum™ • Digital Radome
Target Expansion	<ul style="list-style-type: none"> • All
Expansion Level	<ul style="list-style-type: none"> • Digital Radome
Guard Zones	<ul style="list-style-type: none"> • All = 2
Guard Zone Sensitivity	<ul style="list-style-type: none"> • All
Radar Targets	<ul style="list-style-type: none"> • Magnum Open Array = 25 • Quantum™ 2 Doppler = 25 • Quantum™ = 10 • SuperHD™ Open Array = 25 • HD Open Array = 25 • HD Radome = 25 • Digital Radome = 10
Auto acquire (targets)	<ul style="list-style-type: none"> • Magnum Open Array = 25 • Quantum™ 2 Doppler = 25
Tuning	<ul style="list-style-type: none"> • Magnum Open Array • SuperHD™ Open Array • HD Open Array • HD Radome
Transmit Frequency	<ul style="list-style-type: none"> • Quantum™ 2 Doppler • Quantum™

Features/settings	Radar type
Scanner Rotation Speed	<ul style="list-style-type: none"> • Magnum Open Array = 24 RPM / Auto (48 RPM) • Quantum™ 2 Doppler = 24 RPM • Quantum™ = 24 RPM • SuperHD™ Open Array = 24 RPM / Auto (48 RPM) • HD Open Array = 24 RPM / Auto (48 RPM) • HD Radome = 24 RPM / Auto (48 RPM) • Digital Radome = 24 RPM
Sea Clutter Curve	<ul style="list-style-type: none"> • All
Parking Offset	<ul style="list-style-type: none"> • Magnum Open Array • SuperHD™ Open Array • HD Open Array
Antenna Size selection	<ul style="list-style-type: none"> • Magnum Open Array • SuperHD™ Open Array = 4ft / 6ft • HD Open Array = 4ft / 6ft
Timed Transmit	<ul style="list-style-type: none"> • All
Bearing Alignment	<ul style="list-style-type: none"> • All
MBS (Main Bang Suppression) Off	<ul style="list-style-type: none"> • All
Tuning Preset	<ul style="list-style-type: none"> • Magnum Open Array • SuperHD™ Open Array • HD Open Array • HD Radome • Digital Radome
STC (Sensitivity Time Control) Preset	<ul style="list-style-type: none"> • Digital Radome
VRM/EBL (Variable Range Markers/Electronic Bearing Line)	<ul style="list-style-type: none"> • All
Display Timing	<ul style="list-style-type: none"> • SuperHD™ Open Array = 0–767m • HD Open Array = 0–767m • HD Radome = 0–767m • Digital Radome = 0–153.6m
Max Range	<ul style="list-style-type: none"> • Magnum Open Array = 4kW = 72nm, 6kW = 96nm • Quantum™ 2 Doppler = 24nm • Quantum™ = 24nm • SuperHD™ Open Array = 72nm • HD Open Array = 72nm • HD Radome = 48nm • Digital Radome = 48nm
Colors	<ul style="list-style-type: none"> • Magnum Open Array = 256 • Quantum™ 2 Doppler = 256 • Quantum™ = 256 • SuperHD™ Open Array = 256 • HD Open Array = 256 • HD Radome = 256 • Digital Radome = 8

Compatible Radar scanners

- Magnum Open Array.
- Quantum™ 2 Doppler.
- Quantum™.
- SuperHD™ Open Array.
- HD Open Array.
- HD Radome.
- Digital Radome.

11.3 Opening the Radar app

The Radar app is opened by selecting a page icon from the Homescreen that includes the Radar app.

Pre-requisites:

1. Ensure your Radar scanner is compatible, check the latest details available on the Raymarine website, if in doubt please contact an authorized Raymarine dealer for advice.
2. Ensure you have installed your Radar scanner in accordance with the documentation that was supplied with your Radar.

The Radar app will open in 1 of 3 states:

Off/Not Connected

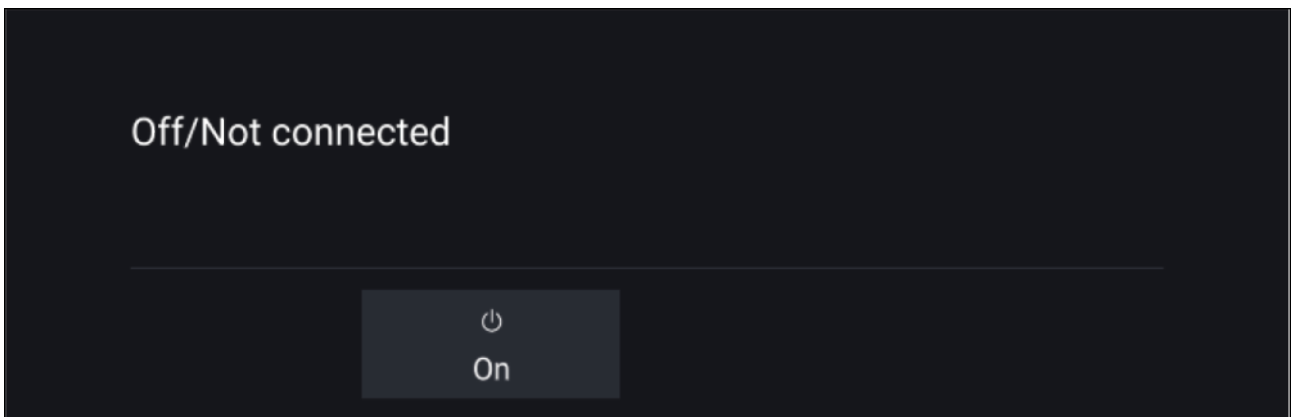

If the '**Off/Not Connected**' message is displayed then:

- your Radar scanner may be powered down, or
- your MFD cannot establish a connection with your Radar scanner

Select **On** to power up your Radar. If the '**Radar not found**' message is displayed then a connection could not be established, ensure that network and power connections to your Radar and MFD are correct and free from damage and then power cycle your system. If the Radar scanner can still not be found refer to your Radar's installation documentation for further troubleshooting information.

Off

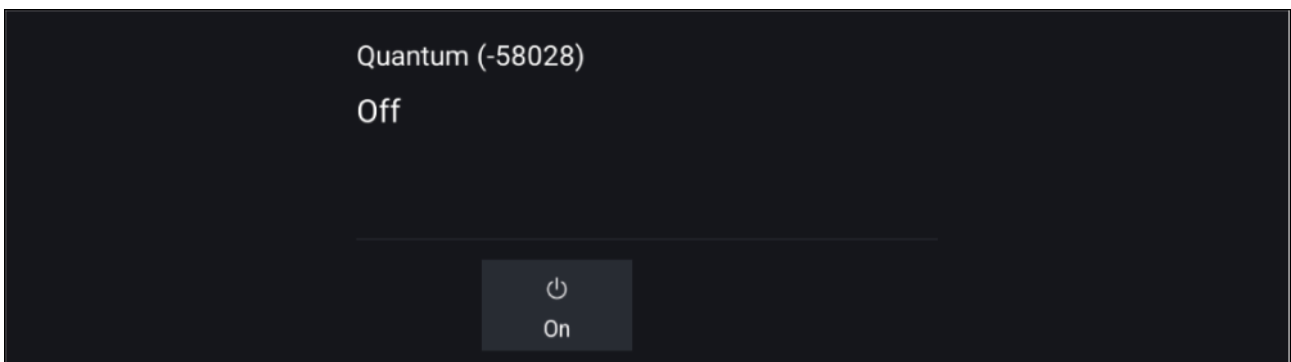

If the '**Off**' message is displayed then your Wi-Fi connected Radar scanner is paired but powered off, select **On** to power up your Radar

Standby (Not transmitting)



If the 'Standby' message is displayed then select **Transmit** to begin transmitting.

Transmitting

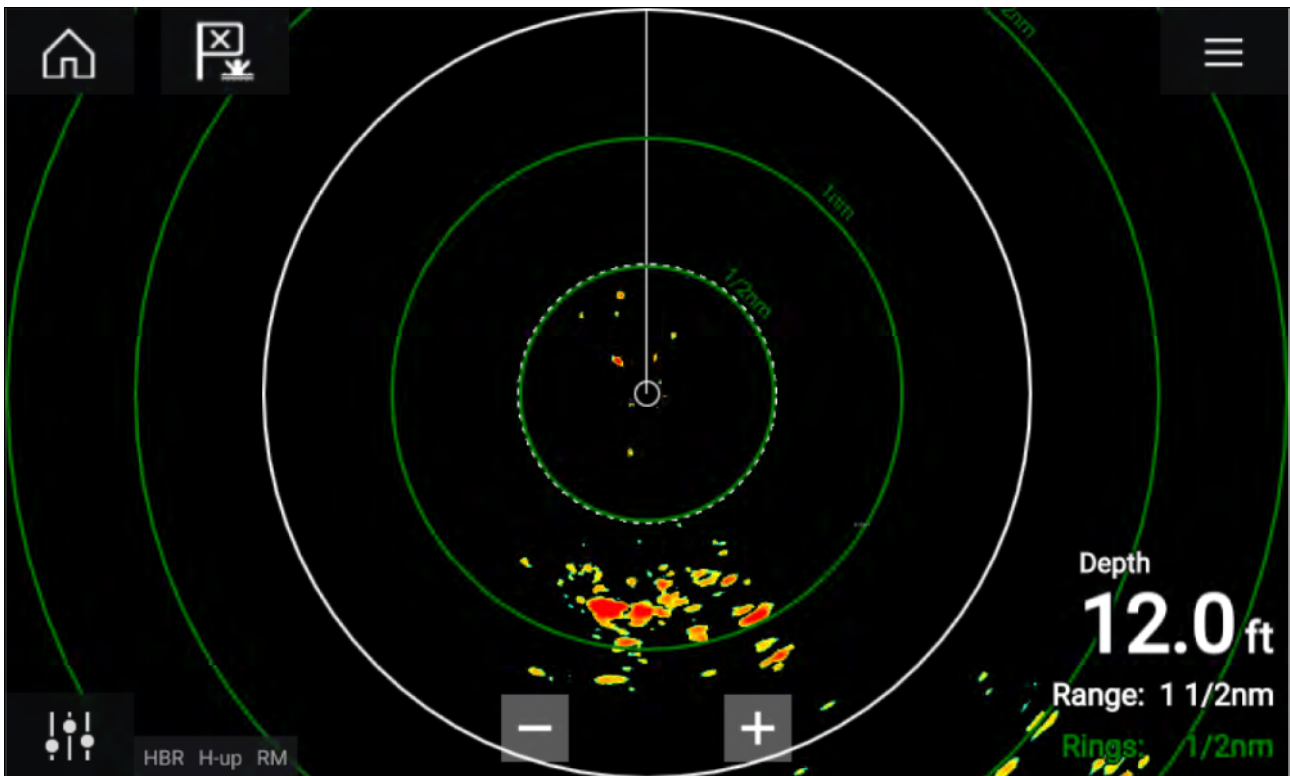

If your Radar scanner is connected, powered up and transmitting then the Radar image is displayed and echoes/targets are displayed onscreen.

Putting the radar into standby

With your selected radar displayed onscreen:

1. Select **Transmit** from the main menu.
The radar scanner will stop transmitting and is put into standby mode.

Powering down your radar scanner

With your radar scanner in standby mode:

1. Select the **Off** icon.
2. Select **Yes** to confirm power down.

The radar scanner will still consume a small amount of power whilst it is powered off, this is to ensure the radar can be powered back up quickly.

11.4 Set up

Selecting a Radar scanner

On systems with 2 Radar scanners, you can select which Radar scanner is used in each instance of the Radar app.

1. Select the **Settings** icon from the Radar app menu.

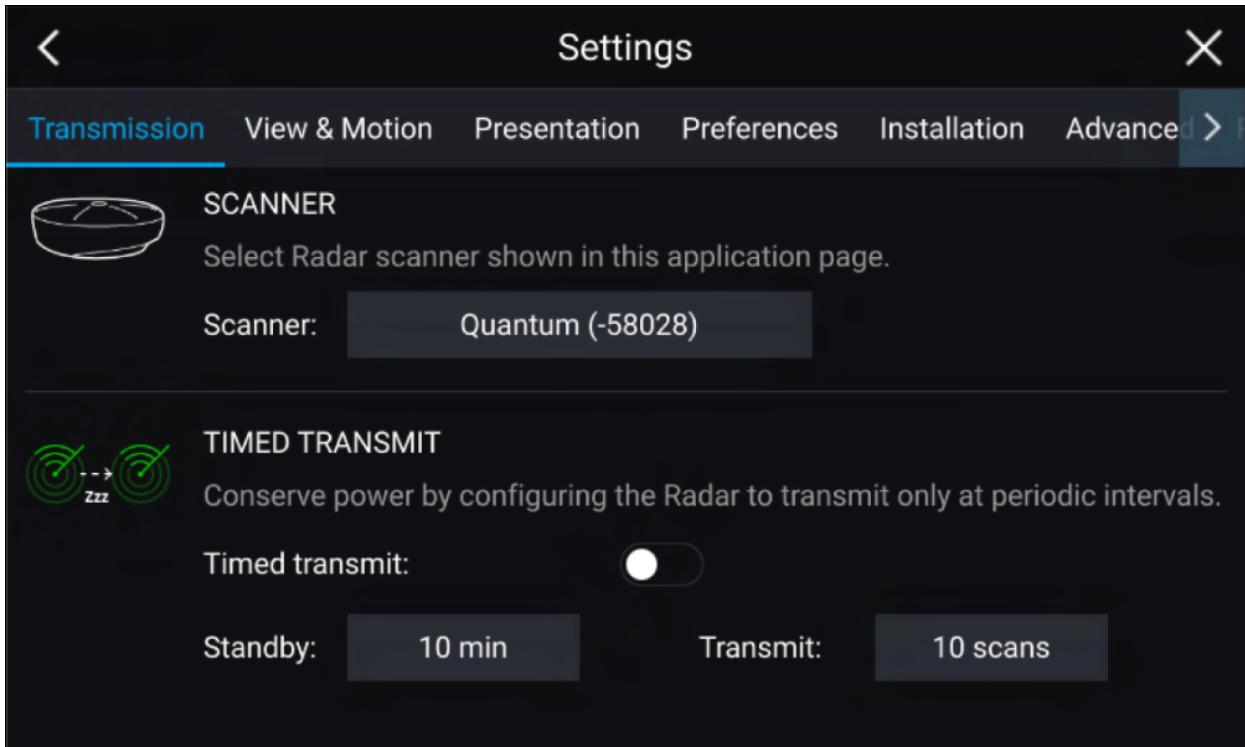

2. Select the **Scanner:** box on the **Transmission** tab.
A list of available Radar scanners is displayed.
3. Select the Radar scanner that you want to associate with the current instance of the Radar app.
4. Close the **Settings** page.

The current instance of the Radar app will change to display the selected Radar scanner. Radar scanner selection shall persist over a power cycle.

Alternatively, with the Radar powered off or in Standby, you can select switch Radar scanner by selecting **Change scanner**.

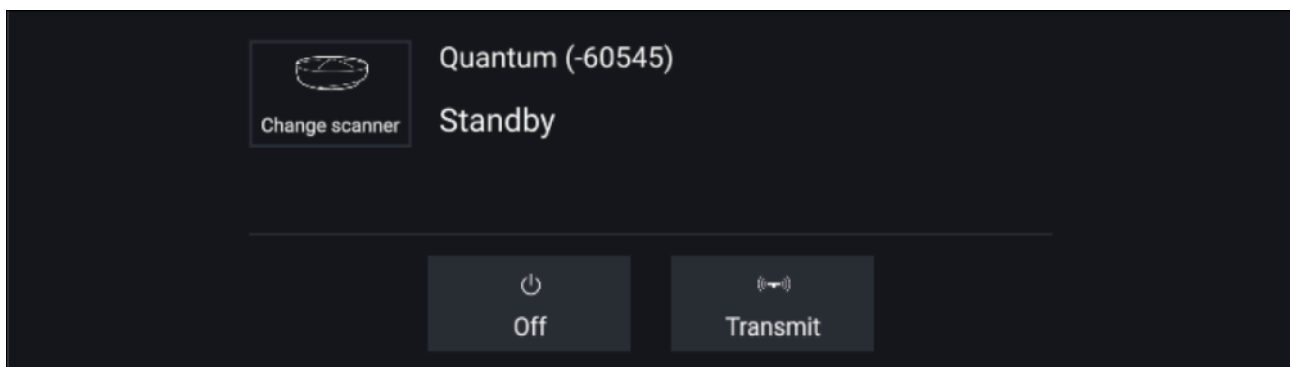

Dual range

HD and SuperHD Radar scanners are capable of **Dual range**. Dual range enables you to view 2 ranges (i.e. Short range and Long range) simultaneously.

To view both ranges you will need to configure a splitscreen, dual Radar, app page that displays the same Radar scanner in each window. You can then enable **Dual Range** mode and set the **Channel** for each window from the **Transmission** tab: **Menu > Settings > Transmission**.

Dual range limitations:

- Dual range cannot be enabled when Radar targets are being tracked (clear the target list and try again).
- When Dual range is enabled Radar target tracking is disabled.
- When Dual range is enabled Automatic Radar target acquisition is disabled.
- In Dual range the maximum rotation speed is 24rpm.
- When using a SuperHD Radar **Antenna boost** and **Power boost** controls are only applied to the Long range channel. Open Array Radar scanners running version 1.xx or 2.xx software will have the Short range channel's maximum range restricted to 3 nm.
- When Dual range is enabled on a Radar scanner running version 1.xx or 2.xx software the **Expansion** control will be disabled.

Timed Radar transmission

To help conserve power you can configure your Radar to only transmit periodically.

From the Radar menu:

1. Select the **Settings** icon.
The settings page is displayed.
2. Switch on **Time Transmit**: using the toggle switch.
3. Select **Standby**: and choose a time interval.
4. Select **Transmit**: and choose the number of rotations you want the Radar to perform.

The Radar will transmit for the specified number of rotations and then will switch to Standby for the specified time interval, the sequence will repeat until Timed Transmit is switched off.

The Timed transmit will revert to Off after a power cycle.

Setting open array antenna size

When connected to an Open Array Radar Scanner you can configure the **Antenna size**. Setting the antenna size can help when setting a **Parking offset**.

From the Radar app:

1. Select **Menu > Settings > Transmission**.
2. Select the correct size for your Radar's antenna from the **Antenna size** option.

Bearing alignment

The Radar bearing alignment ensures that Radar objects appear at the correct bearing relative to your vessel's bow. You should check the bearing alignment for any new installation.

Checking alignment

Align the bow with a stationary object between 0.25 and 2 NM away.

Reduce the gain to make the target as small as possible on the screen.

Note the position of the object on the Radar screen. If the target is not under the ship's heading marker (SHM), then bearing alignment adjustment is required.

Adjusting alignment

Adjust the **Bearing alignment** setting until the target object appears under the SHM.

Bearing alignment setting can be accessed from the **Installation** tab: **Menu > Installation > Bearing alignment**.

Note: Heading (HDG) is displayed in the Radar application. Please be aware that bearing alignment refers to the **relative** bearing of **targets** to the vessel's bow using visual checks / traditional means.

11.5 Radar modes

The Radar app provides preset modes that can be used to quickly achieve the best picture depending on your current situation. Only Radar modes supported by your Radar scanner are shown. To change Radar mode select the required mode from the Radar app menu.



HARBOR

Harbor mode takes into account land clutter that is typically encountered in a Harbor, so that smaller targets are still visible. This mode is useful when navigating in a Harbor.

Radar scanners: All.



BUOY

Buoy mode enhances the detection of smaller targets such as mooring buoys, and is useful at ranges up to 3/4nm.

Radar scanners: SuperHD™ Open Array, HD Open Array and HD Radome.



COASTAL

Coastal mode takes into account slightly higher levels of Sea clutter that are encountered out of Harbor areas. This mode is useful when in open water but keeping to coastal areas.

Radar scanners: All.



OFFSHORE

Offshore mode takes into account high levels of Sea clutter so that targets are still visible, useful when navigating in open water away from the coast.

Radar scanners: All.



BIRD

Bird mode optimizes the display to help identify flocks of birds, useful when trying to locate a fishing area.

Radar scanners: SuperHD™ Open Array, HD Open Array and HD Radome.



WEATHER

Weather mode optimizes the display to help identify precipitation, useful for helping determine weather fronts.

Radar scanners: Quantum™ and Quantum™ 2 Doppler.

11.6 Range and bearing

The Radar app helps you identify a target's range (distance) and bearing from your vessel.

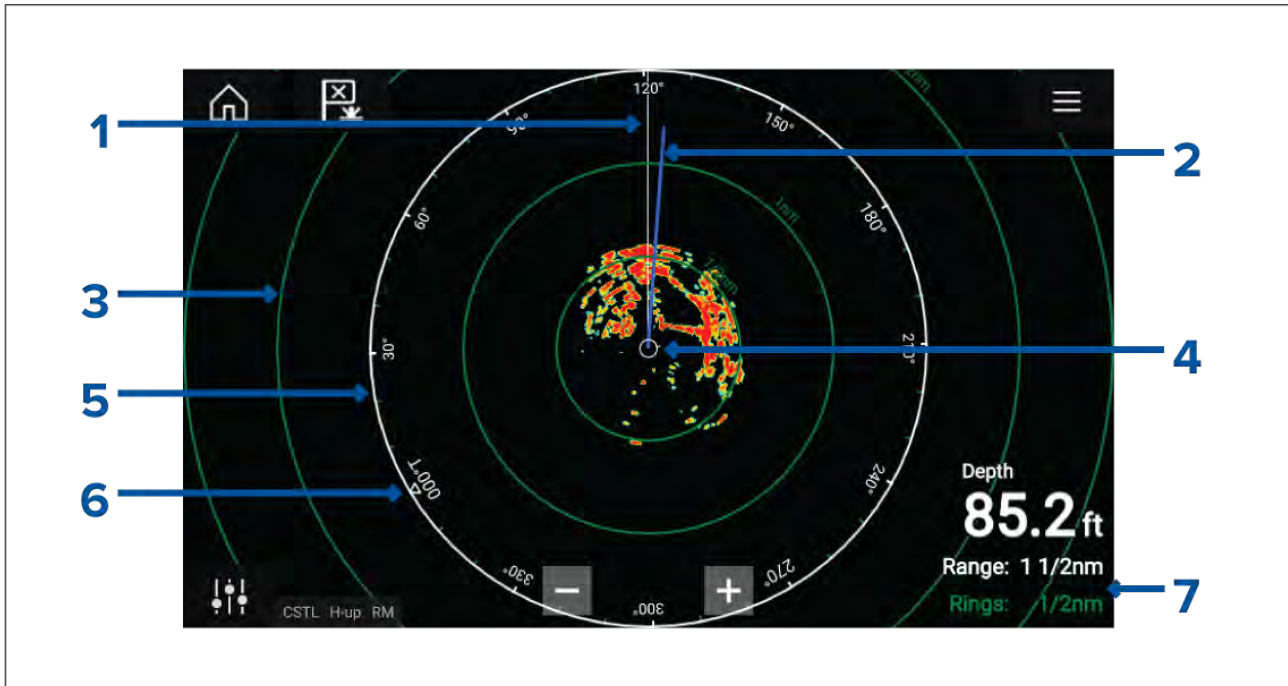

1. SHM (Ships heading marker).
2. COG/SOG line (Points in the direction of travel (COG), with the length of the vector providing an indication of speed (SOG)).
3. Range rings.
4. Vessel position.
5. Range and bearing indicator (The White ring identifies the distance from your vessel to the top edge of the screen. Bearing indicators are also provided around the ring).
6. North indicator (Always points North).
7. Current displayed Range and Ring separation distance (Range: identifies the distance from your vessel to the top edge of the screen. Rings: identifies the distance between each Range Ring).

The displayed range can be adjusted at anytime using the Range controls.

Range rings can be switched off from the Presentation tab: **Menu > Settings > Presentation > Range rings:**

You can also choose whether to display a numerical range indicator against each ring using the **Range ring labels:** option.

VRM (Variable Range Marker) / EBL (Electronic Bearing Line)

VRM/EBL is used to determine a targets range and bearing from your vessel, or from another target. 2 VRM/EBLs are available which are enabled from the context menu.

Context menu > More options > VRM/EBL 1 or **Context menu > More options > VRM/EBL 2**

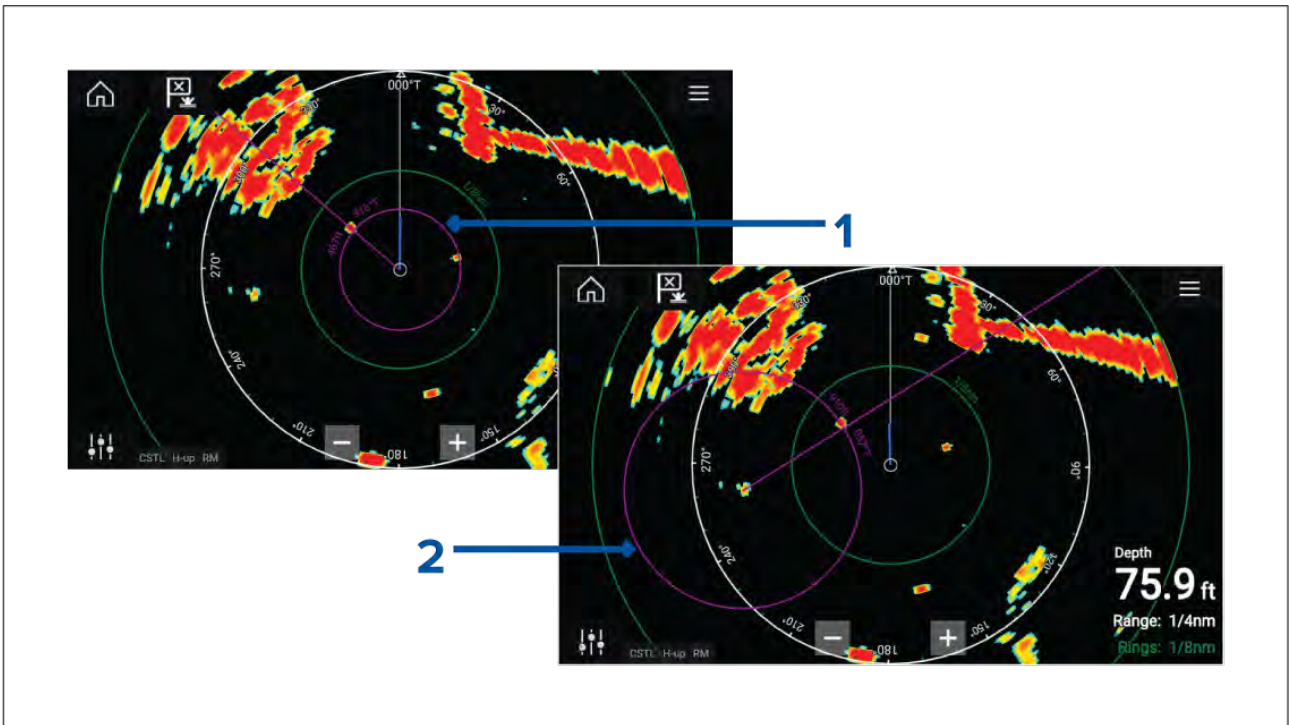

1. **Centered VRM/EBL** You can use a 'Centered' (on your vessel) VRM/EBL to determine the range and bearing of targets in relation to your vessel.
2. **Floating VRM/EBL** You can use a 'Floating' VRM/EBL to determine the range and bearing between 2 targets.

Editing a VRM-EBL

Once a VRM/EBL has been placed you can adjust its size and position.

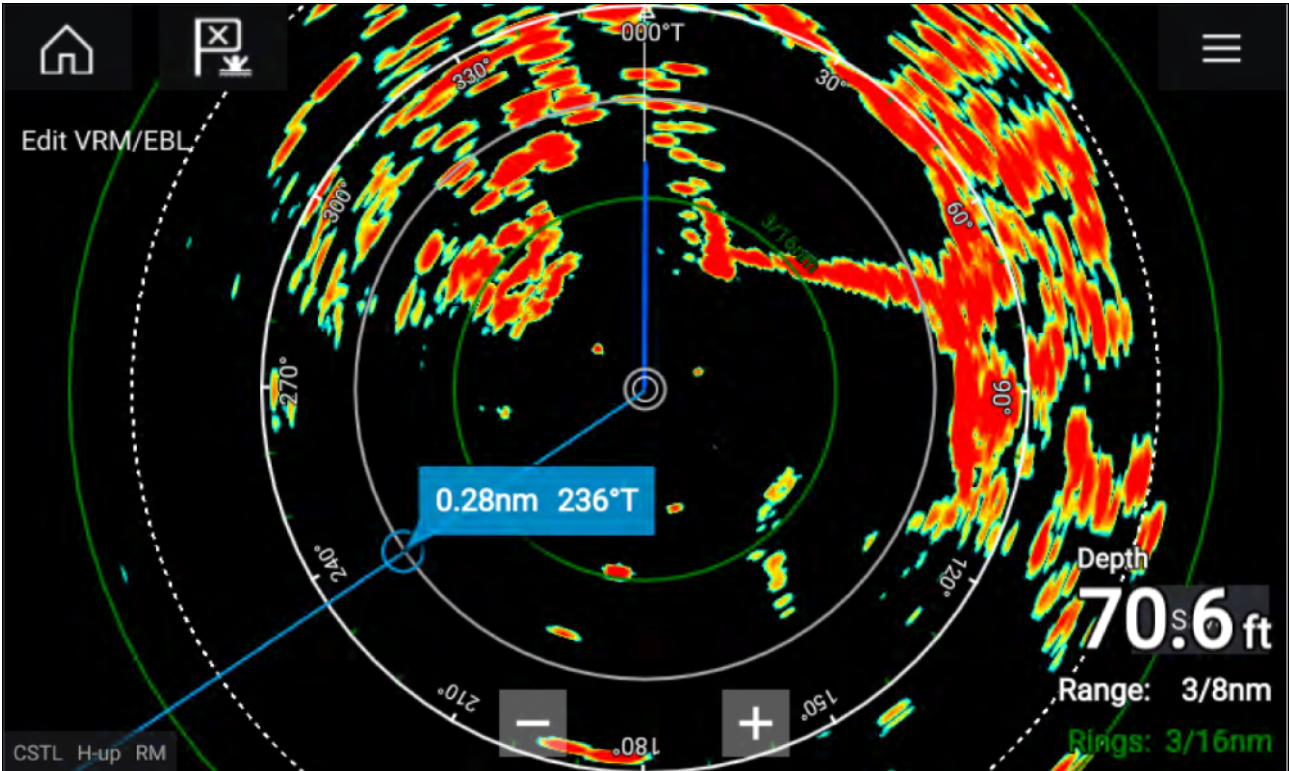

1. Select **Edit VRM/EBL** from the context menu.
2. To adjust the VRM/EBL select the desired target or drag the labelled circle to the target.
3. To create a floating VRM/EBL Drag the center circle to the desired target.

11.7 AIS targets

With compatible AIS hardware connected to your MFD, AIS targets can be automatically displayed in the Chart app and Radar app.

Tracked AIS targets are identified onscreen using target symbols.

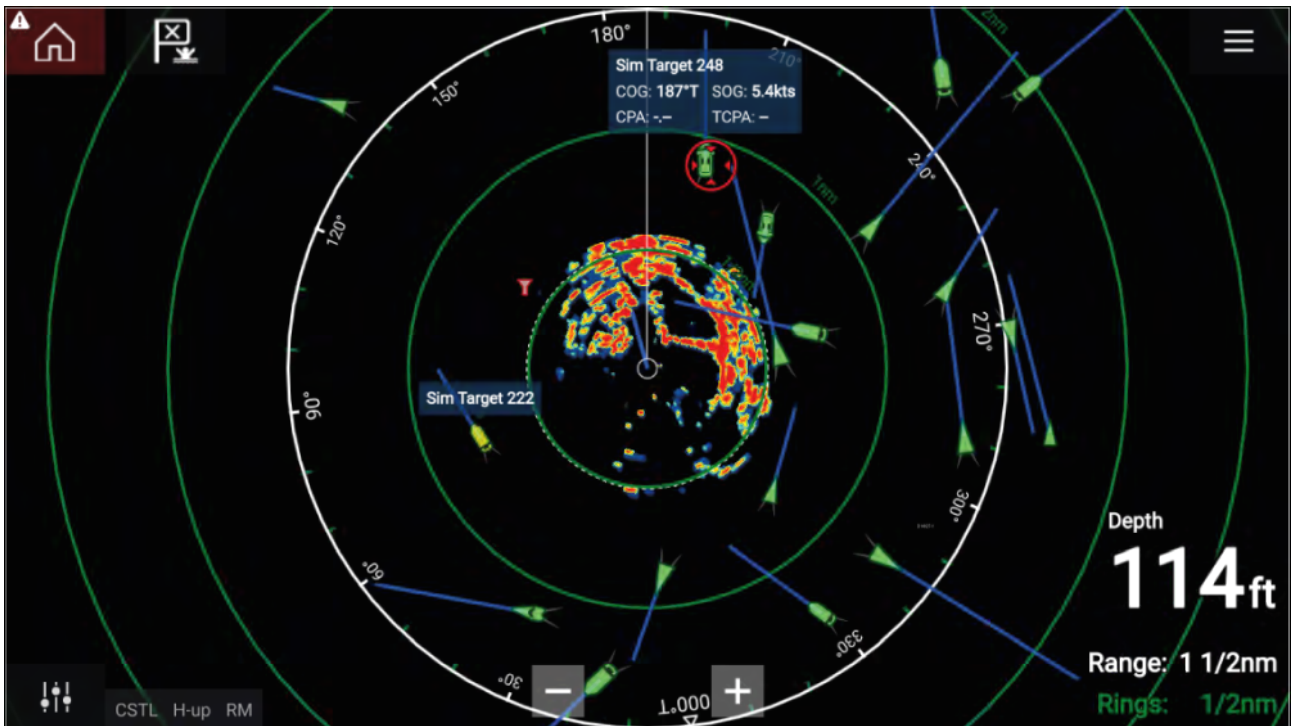

Up to 100 AIS targets can be tracked simultaneously. If more than 100 targets exist, within your range, the 100 targets nearest to your vessel will be displayed.

Target vectors and information can be displayed for each target by selecting the relevant option from the AIS target context menu. The AIS target context menu is accessed by selecting the AIS target.

You can also select the type of AIS targets that should be displayed, i.e.: **All**, **Dangerous**, **Buddies** and hide static targets from the AIS Settings tab.

AIS target list

AIS targets appear in the AIS target list.

The AIS target list can be accessed by selecting the **AIS** tab from the **Targets** menu: **Menu > Targets > AIS**.



The list identifies: Target name and Range and Bearing (from your vessel). Where relevant, CPA (Closest point of approach) and TCPA (Time to Closest Point of Approach) values are also shown.

Selecting a target from the list will highlight the selected target in the **LiveView** pane on the right of the screen and display Pop-over options. Pop-over options enable you to **View full target data** or add an AIS target a buddy by selecting **Add as buddy**.





AIS icons used for targets marked as buddies will be filled yellow. You can also rename buddy targets or remove buddies using the Pop-over options.





AIS target symbols

By default, standard AIS symbols are used to identify AIS targets.

You can enable enhanced AIS target symbols from the **Advanced Settings** menu: (**Menu > Settings > Advanced > Enhanced AIS targets**). With enhanced mode enabled, the enhanced symbols are used in place of the standard vessel symbols.

Standard AIS symbols — type

	Vessel		SART (Search and Rescue Transponder)
	Land-based station		ATON

	SAR (Search and Rescue)		Virtual ATON
	* Blue Force vessel		* Blue Force SAR







Note: * Requires STEDS-AIS hardware.

Vessels equipped with STEDS-AIS hardware appear as Blue Force targets if:

- your MFD has a valid passphrase.
- you have received a SITREP from them within the last 6 minutes.
- their AIS mode is not set to Receive only.

If the above conditions are not met then the target icon will revert to using the standard, Green AIS target icon.





Enhanced AIS symbols – type

	Sailing Vessel		Commercial
	High speed vessel / Wing In Ground vessel		Cargo vessel
	Passenger vessel		Other

Enhanced AIS symbols are scaled or outlined according to the reported size of the vessel, as shown below:

	Relative length (Grey outline)		
---	--------------------------------	--	--

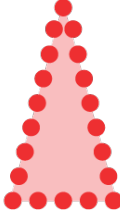
AIS symbol status

	Lost (No border, crossed through)		Uncertain (Dashed outline)
	Buddy (Yellow fill)		Dangerous and Uncertain (Dashed outline and Flashes Red)
	Dangerous (Flashes Red)		ATON off position (Red border)

AIS settings

When the AIS layer is enabled in the Chart app you can configure **AIS settings** from the **Targets** menu: **Menu > Targets > AIS settings**.

Setting	Description	Options
Show AIS targets in Chart / Show AIS targets in Radar	Enables and disables AIS targets in the Chart and Radar apps.	<ul style="list-style-type: none"> • On • Off
Enhanced AIS targets	Enables and disables the display of enhanced AIS target icons.	<ul style="list-style-type: none"> • On • Off
Show these AIS types	Determines the types of AIS target displayed in the Chart and Radar apps.	<ul style="list-style-type: none"> • All • Dangerous • Buddies

Setting	Description	Options
Hide static targets	When enabled, an AIS target travelling under 2 knots will be hidden, unless it is or becomes dangerous.	<ul style="list-style-type: none"> • On • Off
Silent mode	When enabled, your vessel's AIS device will not transmit your position or details.	<ul style="list-style-type: none"> • On • Off

11.8 Radar targets

With a compatible Radar scanner connected to your MFD, radar targets can be tracked in the Chart app and Radar app. Depending on your Radar scanner, radar targets can be acquired manually or automatically, based on your configured **Guard zones**.

Tracked radar targets are identified onscreen using target symbols.

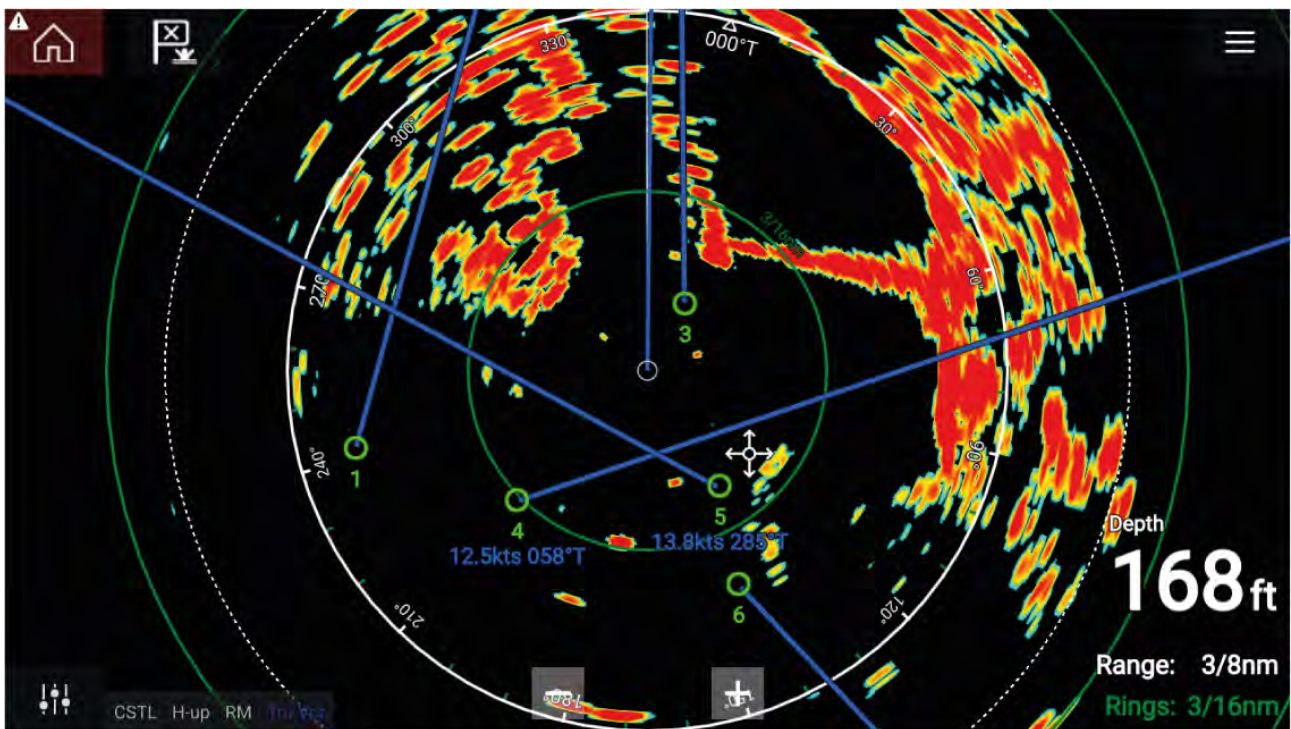

Multiple radar targets can be tracked simultaneously.

Target vectors and information can be displayed for each target.





Radar target options are available from the Radar target context menu. The Radar target context menu provides options for you to **Cancel target**, **Show CPA** graphic or display **Target info** onscreen by selecting the relevant option. The Radar context menu is accessed by selecting the radar target.

Radar target acquisition data source requirements

Radar target acquisition requires the following data sources to be available on your system (e.g. connected to your multifunction display, via SeaTalkng® or NMEA 0183).

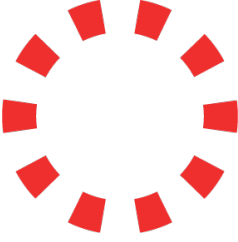
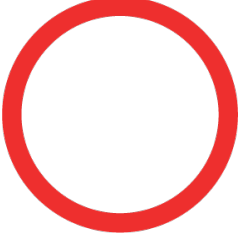
Data type	Example data source
COG (Course Over Ground)	GPS or GNSS receiver (MFD internal receiver or external receiver).
SOG (Speed Over Ground)	GPS or GNSS receiver (MFD internal receiver or external receiver).
HDG / HDT (True Heading)	Compass or Autopilot sensor providing Fastheading data (e.g. Evolution EV-1 / EV-2).

Radar target symbols

Symbol	Status	Description
	Acquiring target — Manual	Thin dashed Green circle
	Acquiring target — Auto	Thick dashed Red circle, flashes until acknowledged
	Auto-acquired target — Unacknowledged	Red circle, flashes until acknowledged
	Acquired target	Green circle with Target ID
	Dangerous target	Red circle with Target ID, flashes until acknowledged
	Lost target (Target not detected for 4 Radar scans)	Gray circle with Red cross through

Once acquired the target's COG (Course Over Ground) and SOG (Speed Over Ground) can be displayed below the target ID.

The Target info is colored Blue if COG and SOG values are True or Orange if values are Relative. Target info will turn Red if the target becomes dangerous.

Acquiring a target manually

To acquire a Radar target manually using MARPA (Mini Automatic Radar Plotting Aid) follow the steps below.

With the Radar app, or Chart app with Radar overlay enabled:

1. Select the target.
The context menu is displayed.
2. Select **Acquire target**.
Once acquired the target will be tracked.

Automatic target acquisition

With a compatible Radar scanner connected, Radar targets can be acquired automatically.

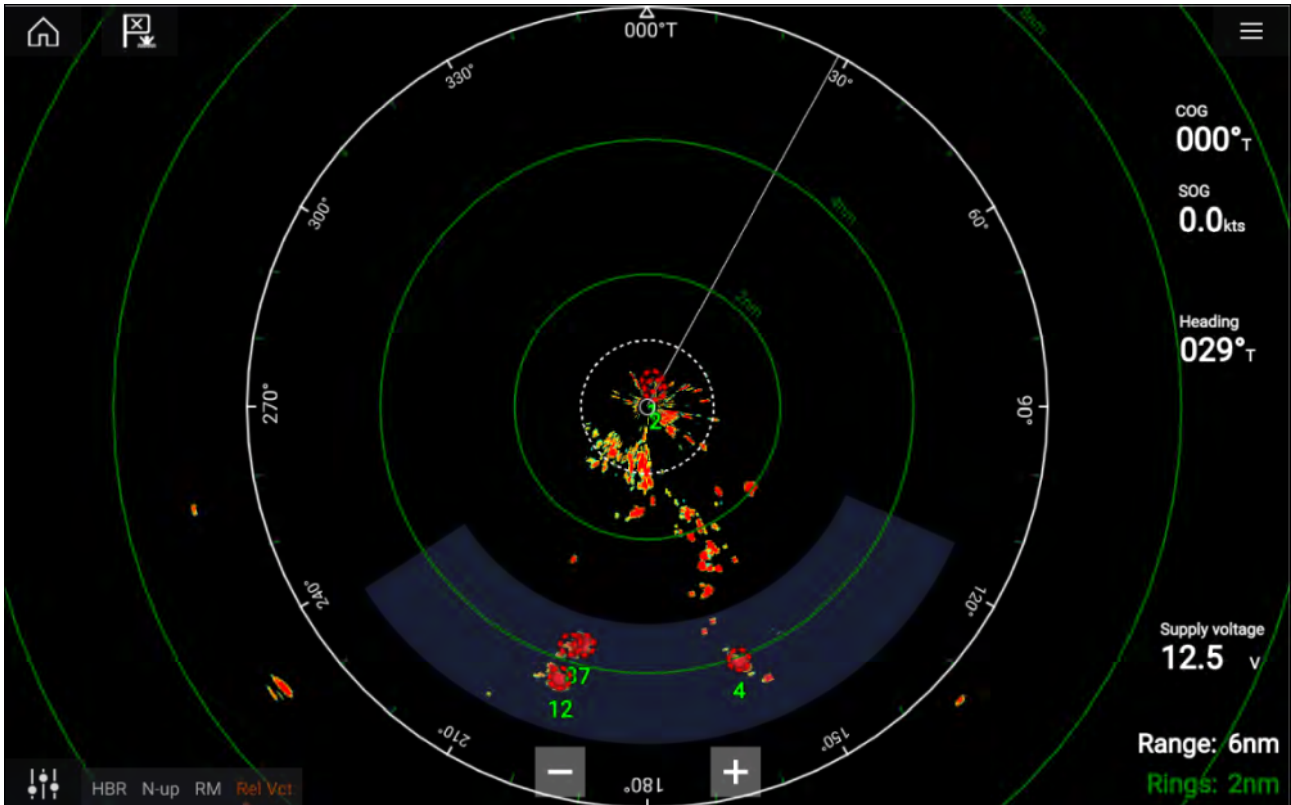

Once configured, targets which enter or appear in your chosen **Guard Zone(s)** will be automatically acquired.

Note:

- Automatic target acquisition cannot be enabled at the same time as **Timed Transmit** or **Dual Range**.
- Automatic target acquisition will be temporarily paused if the Radar display range is 12nm or greater.

Setting up automatic target acquisition

Follow the steps below to configure automatic target acquisition.

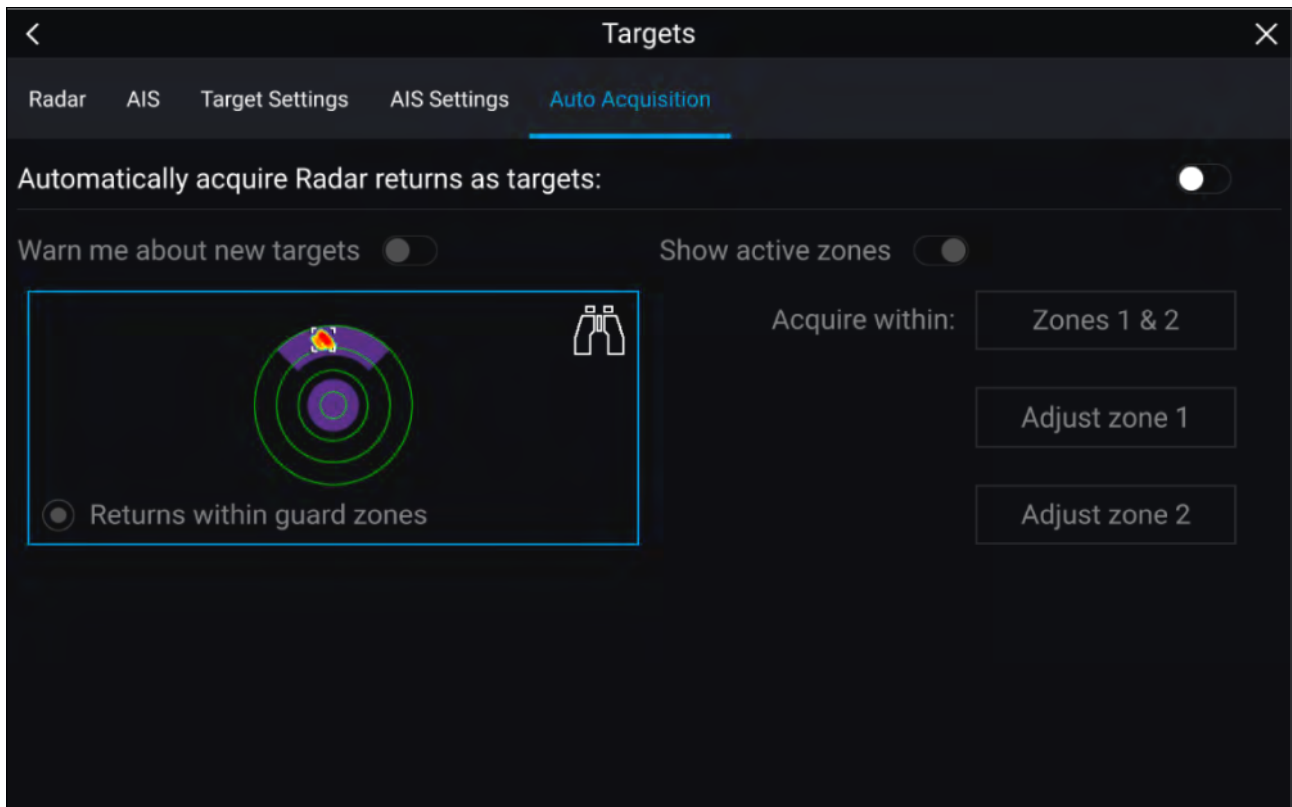

1. Select the **Auto Acquisition** tab from the Target menu: (**Menu > Targets > Auto Acquisition**).
2. Enable Automatic Target Acquisition by selecting the **Automatically acquire Radar returns as targets** toggle switch.
3. Select the **Acquire within** box and choose **Guard zone 1**, **Guard zone 2** or **Zones 1 & 2** as required.
4. To enable onscreen pop-up notifications of new targets which have been acquired automatically, select the **Warn me about new targets** toggle switch.
When multiple targets are acquired simultaneously, an Info dialog is displayed.
5. You can also adjust the size and position of the Guard zones directly from the **Auto Acquisition** page by selecting **Adjust zone 1** or **Adjust zone 2**.

Radar target list

Tracked Radar targets appear in the Radar target list.

The AIS target list can be accessed by selecting the **Radar** tab from the **Targets** menu: **Menu > Targets > Radar**.

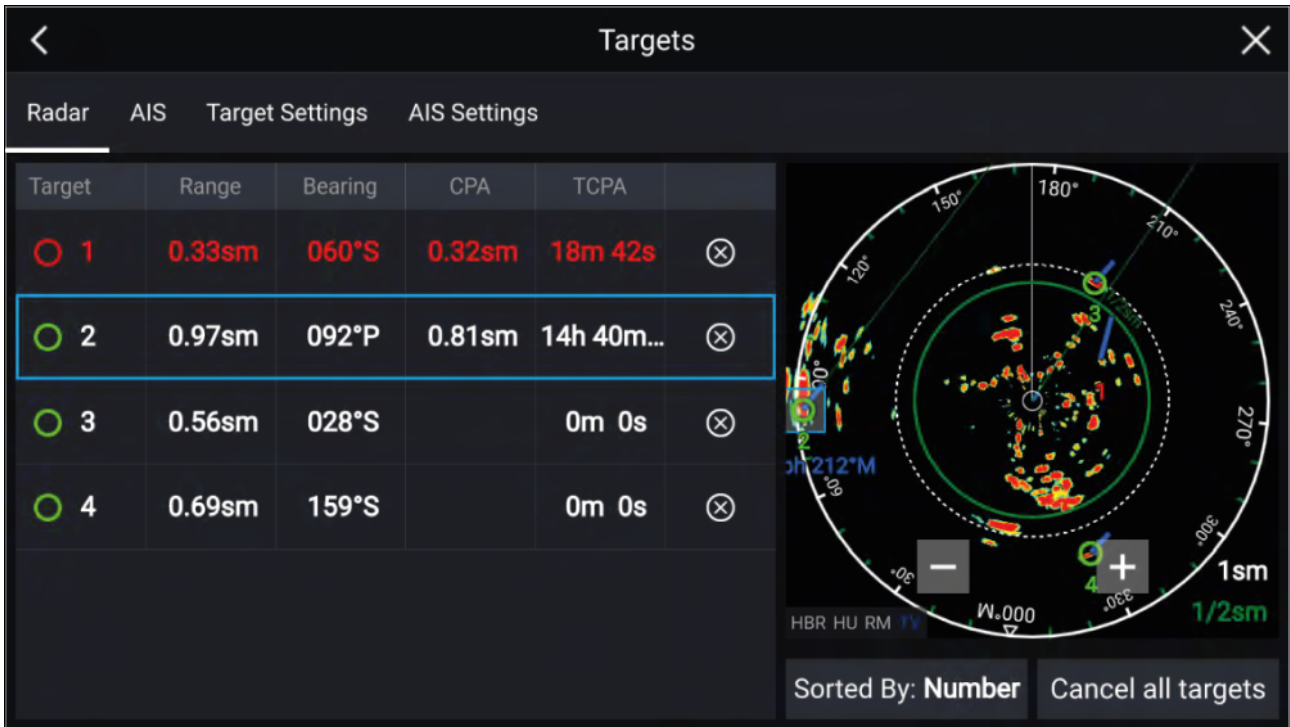

The list identifies: Target number and Range and Bearing (from your vessel). Where relevant, CPA (Closest point of approach) and TCPA (Time to Closest Point of Approach) values are also shown.

Selecting a target from the list will highlight the selected target in the **LiveView** pane on the right of the screen and display Pop-over options. Pop-over options enable you to **Cancel target**, **Show CPA** graphic or Display **Target info** by selecting the relevant option.

The Radar target list can be **Sorted By:** target **Number** or its **Range** from your vessel, by selecting the Sorted By: option at the bottom of the **LiveView**.

Radar targets can also be cancelled individually by selecting the 'X' next to the target's details in the list, or you can cancel all targets by selecting **Cancel all targets**.

Target settings

Target vectors, target history and object trail graphics can be displayed onscreen to improve situational and collision awareness.

Target settings can be accessed from the **Target Settings** tab: **Menu > Targets > Target settings**.

Reference mode

Target settings can be configured to either **True** or **Relative** mode. In True mode, Trails, Vectors and History are colored Blue and are shown ground referenced (i.e. the object or target's actual Course Over Ground (COG)). In Relative mode, Trails, Vectors and History are colored Orange and are shown relative to your vessel's movement.

To switch the target reference mode, select the **REFERENCE MODE** setting. Alternatively, you can switch reference mode by selecting the onscreen **Image Adjustment** icon and then selecting either **True** or **Relative**.

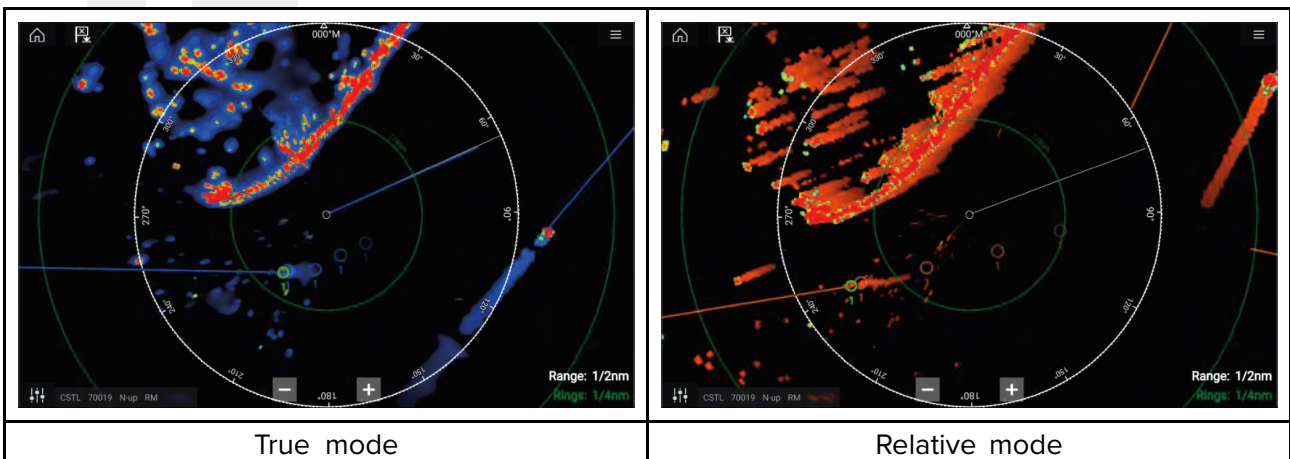

The **Target Settings** reference mode is independent of your vessel's motion mode.

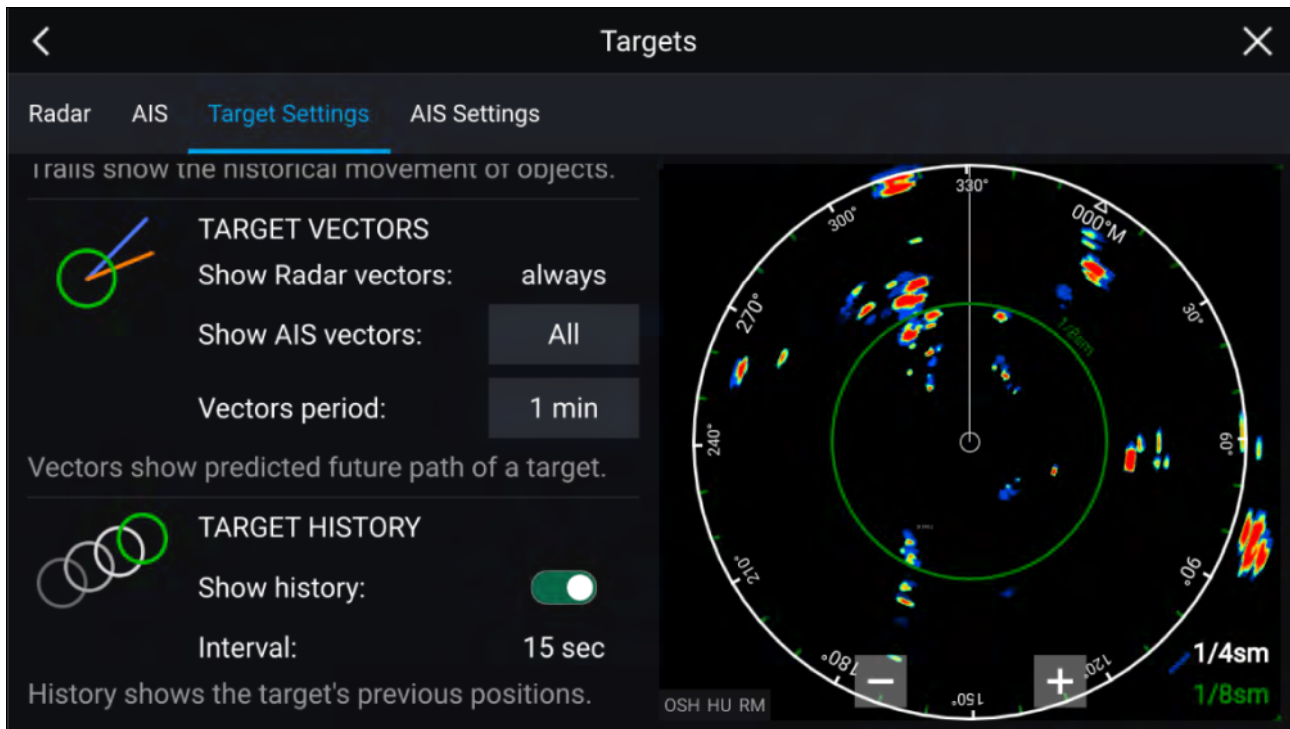

Target vectors

Target vectors show the predicted future course of a target.

Target vectors for acquired Radar targets are always shown. By default, target vectors are also shown for all AIS targets. You can switch the **Show AIS vectors** to Manual, enabling you to switch vectors for AIS targets On or Off for each target individually, via the target context menu.

The length of the Vector line signifies where the target will be after the time specified in **Vector period** has passed. The Vector period can be adjusted by selecting the current **Vector period** value and choosing a time from the Pop-over options.

Target history

Target history shows a target's previous positions.

Target history can be enabled or disabled using the **Show history** toggle switch.

Target history is plotted by displaying a target symbol at the vessel's position each time the value specified in the **Interval** setting has passed. The **Interval** is automatically calculated based on the target vector's **Vector period**, divided by 4.

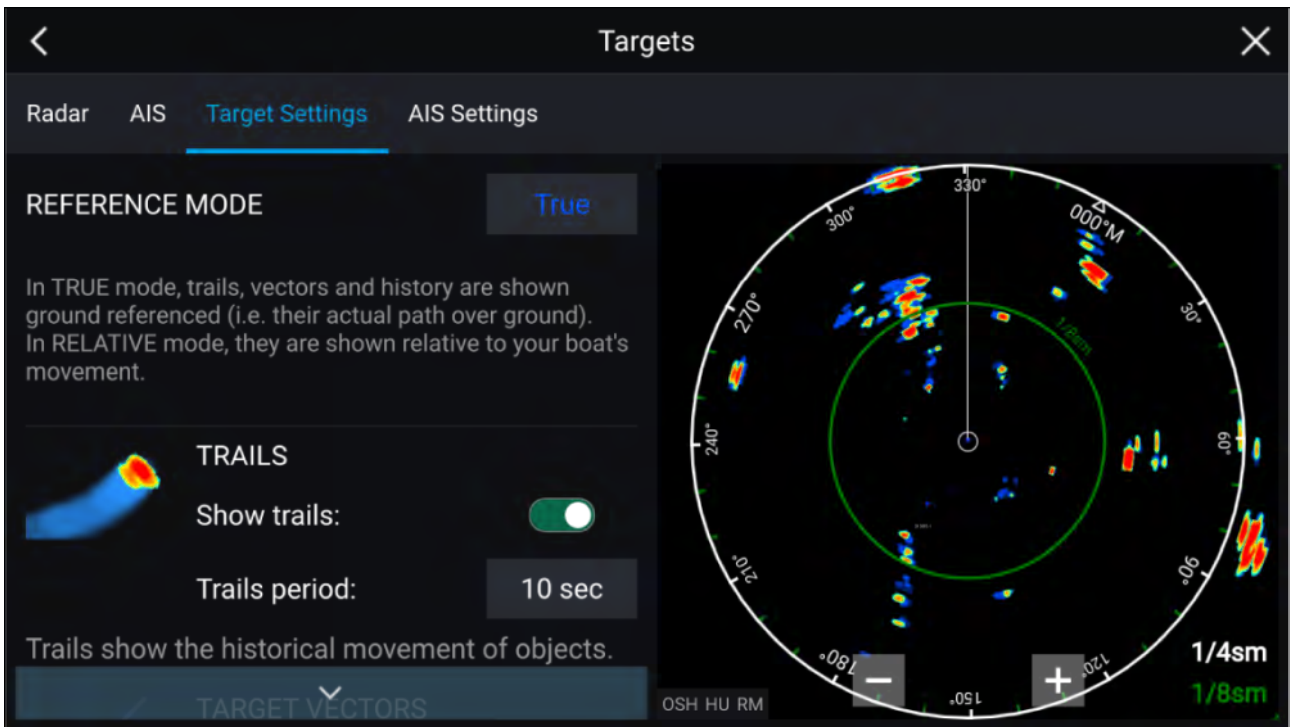

Trails

Trails plot the historical movements of objects (Radar returns) for the time specified in the **Trails period** setting.

Trails are subject to the selected “Reference Mode” (i.e. **True**, to show actual motion over “ground” (COG), or **Relative**, to show motion relative to your vessel).

Trails can be enabled and disabled using the **Show trails** toggle switch.

Historical object position is shown as a colored trail behind the object.

Onscreen target settings

Target settings and information are also available using the onscreen **Image adjustment** icon.

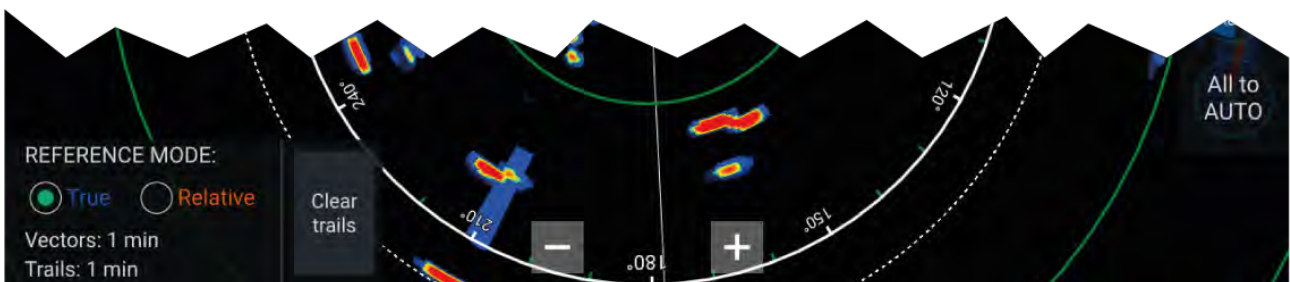

The following target settings and information is available:

- **REFERENCE MODE** — Choose whether Radar targets and objects are displayed in **True** or **Relative** reference mode.
- **Vector period and Trail interval** — Displays currently selected values.
- **Clear trails** — Clears and resets the trails displayed onscreen.

Clearing / resetting trails

In an area with multiple target returns, trails can clutter the Radar image, reducing its ability to provide a target’s path, under these circumstances you can remove all existing trails using the onscreen **Clear trails** option.

1. Select the onscreen **Image adjustment** icon.
2. Select **Clear trails**.

Target context menu

A target context menu is available that provides quick access to useful target settings.

To open the Radar target context menu, select a target onscreen.



CPA: 779ft TCPA: 12m 50s
COG: 334°M SOG: 1.0mph

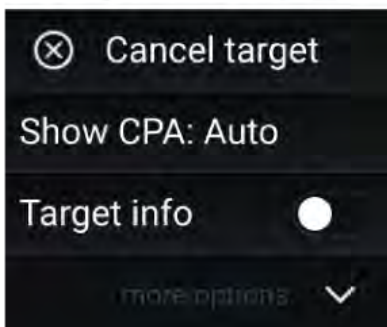

The Radar context menu provides CPA, TCPA, COG and SOG data for the selected target.

The context menu also provides the following target menu options:

- **Cancel target** — The Radar target will no longer be tracked.
- **Show CPA** — Determines whether CPA graphics are shown. The default option is Auto which displays CPA graphics for the target if it becomes dangerous. You can also set CPA graphics to On, which displays CPA graphics, if there is an intersect point between your vessel's current course and the target's. When set to Off no CPA graphics will be displayed for the target.
- **Target info** — Determines whether the target's SOG and COG information is displayed under the target onscreen.

11.9 Dangerous targets alarm

You can use the Dangerous targets alarm to notify you if a Radar or AIS target will reach a specified distance from your vessel within a specified time.

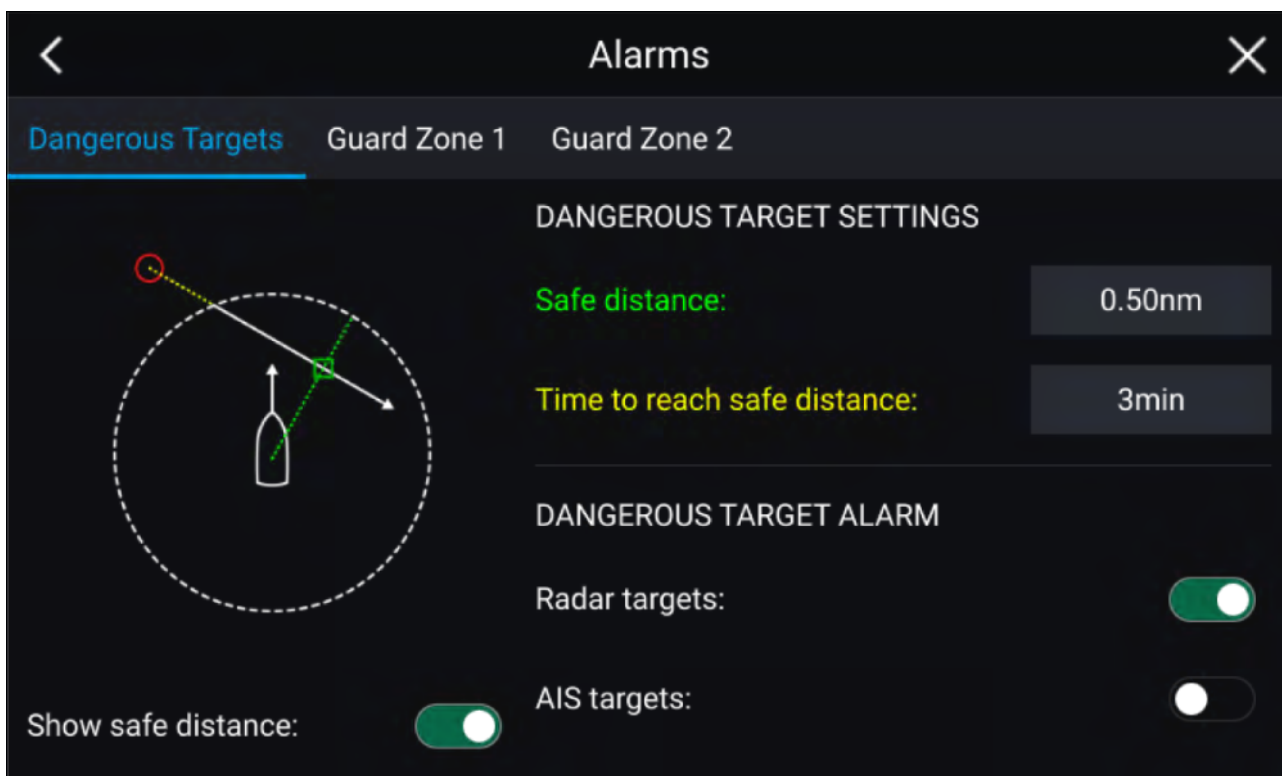

To set up the Dangerous target alarm, first adjust the **Safe distance** to the desired value and then select a **Time to reach safe distance**. The alarm will be triggered if a tracked target will reach the specified Safe distance from your vessel within the time period selected.

You can choose whether you want the Dangerous target alarm to trigger for Radar and / or AIS targets.

You can display a Safe distance ring around your vessel in the Radar app using the **Show safe distance** control.

11.10 Guard zone alarms

Guard zones alert you if a Radar return is detected within the Guard zone area.

2 Guard zones can be configured for each connected Radar scanner.

The Guard zones can be configured from the **Alarms** menu: **Menu > Alarms > Guard zone 1** or **Menu > Alarms > Guard zone 2**

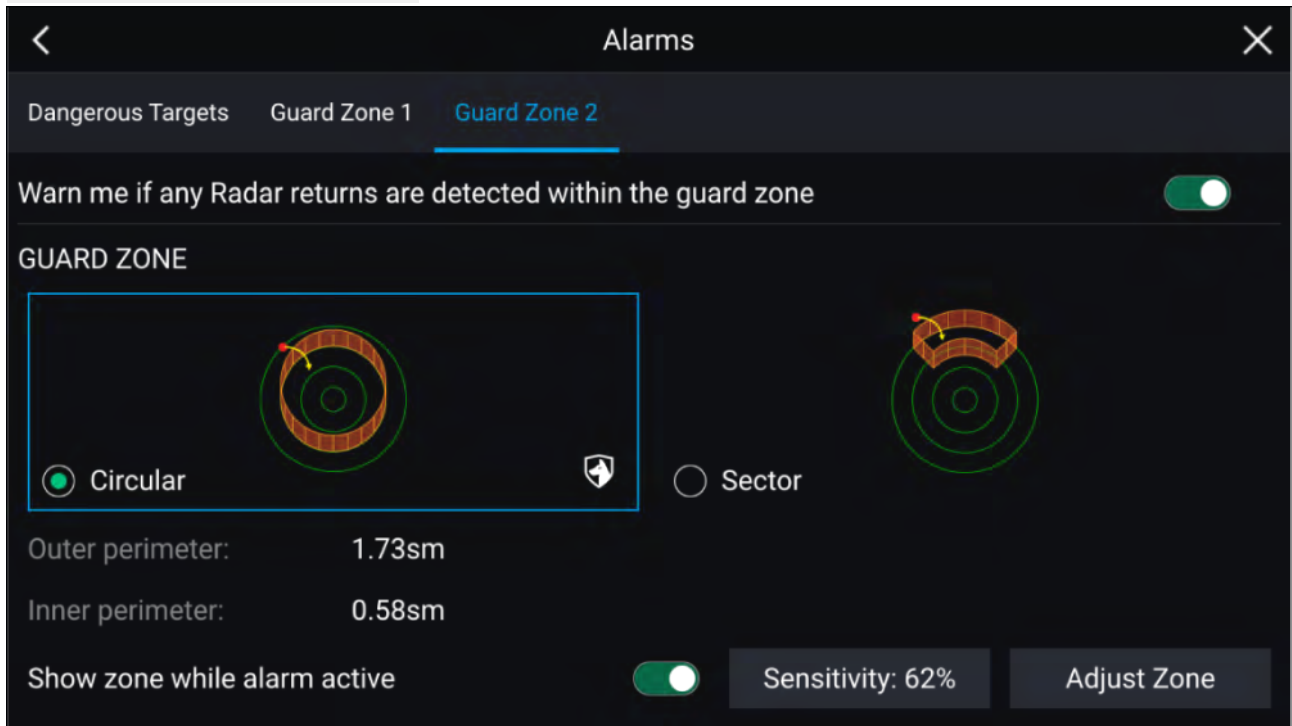

A Guard zone can be configured as a sector or as a circle around your vessel.

Selecting **Adjust Zone** allows you to configure the size of the Guard Zone.



Adjust the guard zone's size by dragging the inner and outer perimeter end points (circles) to the desired locations.

Once configure select **Back**.

If required, you can also adjust the Guard zone sensitivity. Sensitivity determines the size at which objects trigger the alarm.

11.11 Doppler Radar overview

Doppler Radar technology makes it easier to track moving targets with significant ground speed exceeding 3 knots.

Typically Doppler Radar works best with objects that are moving directly towards or away from the vessel. Doppler Radar can highlight only those targets that are moving relative to the vessel (e.g. other boats, but not land or buoys, for example).

Doppler Radar works by transmitting a microwave signal which is then reflected off a desired moving target at a distance. By analyzing how the object's motion has altered the frequency of the returned signal, the Doppler Radar can interpret the variation to provide highly accurate measurements of a target's direction of travel, relative to the Radar scanner.

Doppler Radar technology is particularly beneficial in a marine environment, where poor weather conditions and visibility can make target tracking difficult. Additionally, it is not always easy to interpret the information displayed by traditional Radar technology. With the integration of Doppler information, the process of matching on-screen radar returns with real-world objects becomes a much simpler task.

Doppler mode

When a compatible Radar is connected Doppler mode is available.

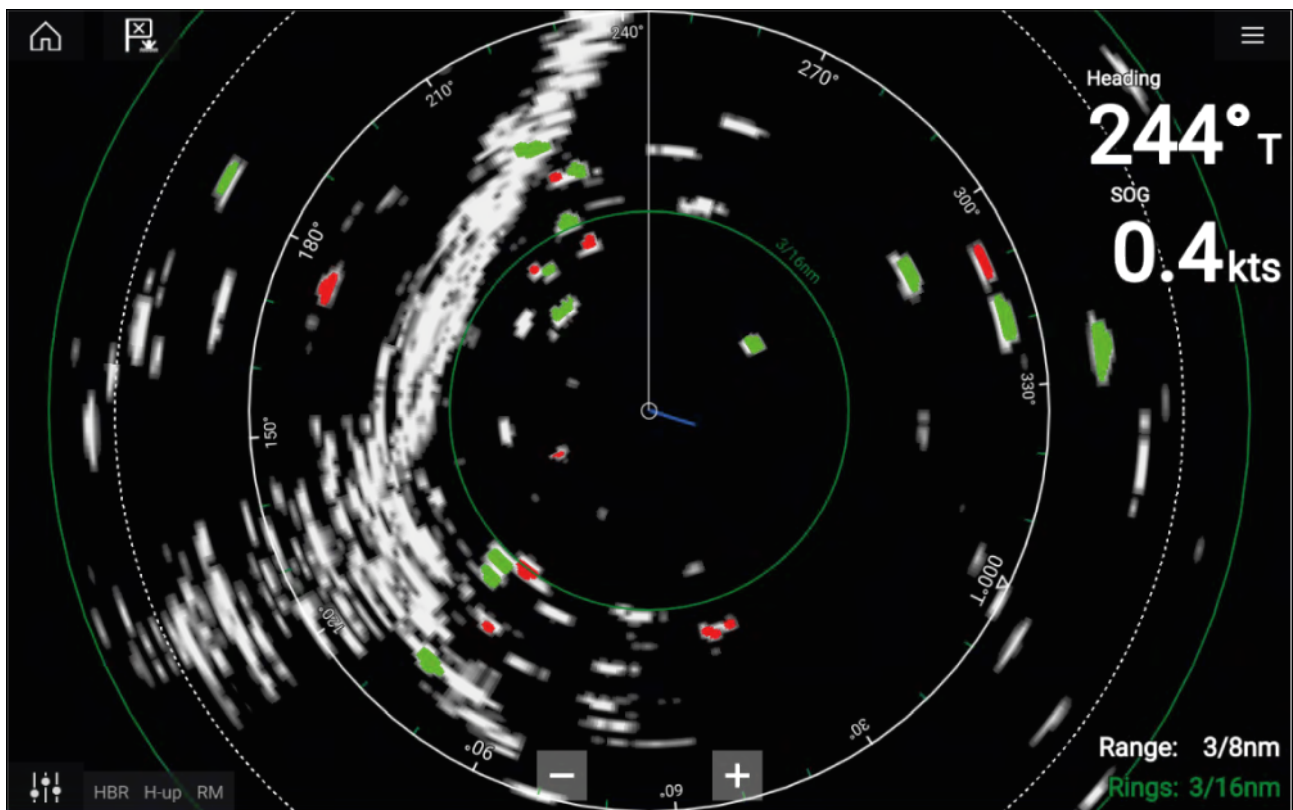

Doppler mode — Enabling and disabling

Doppler mode is enabled from the Main menu: **Menu > Doppler**.

With Doppler mode enabled the color palette will change to the default Doppler palette, all approaching targets will be colored Red and all targets moving away from you will be colored Green.

Doppler mode is suspended at ranges of 12 nm and greater. The Radar color palette will remain the same but targets will not be highlighted.

Doppler mode — Color palettes

Doppler has unique color palettes which help to ensure the Red and Green Doppler targets stand out from the Radar image. When Doppler is enabled the standard color palette setting will show only the unique Doppler color palettes: **Doppler grey**, **Doppler blue** and **Doppler yellow**.

The Color palettes can be selected from the Presentation tab: **Menu > Settings > Presentation**.

Doppler data source requirements

Use of the Doppler Radar features requires the following data sources to be available on your system (e.g. connected to your multifunction display, via SeaTalkng[®] or NMEA 0183).

Required data sources

Data type	Example data source
COG (Course Over Ground)	GPS or GNSS receiver (MFD internal receiver or external receiver).
SOG (Speed Over Ground)	GPS or GNSS receiver (MFD internal receiver or external receiver).

Recommended data source

Data type	Example data source
HDG / HDT (True Heading)	Compass or Autopilot sensor providing Fastheading data (e.g. Evolution EV-1 / EV-2).

Note:

A Heading data source is not essential for Doppler operation. However it will improve the performance of Doppler mode at slower speeds (< 15 knots), when tide set and leeway are present.

11.12 Blank sectors

Blank sectors can be manually set to hide sections of your radar display. This is useful for vessels that experience false radar readings from onboard structures or equipment.

Note:

Sector blanking is only compatible with Magnum Open Array radar scanners.

Blank sectors can be enabled from the Radar app settings: **Radar app > Settings menu > Installation**

Two blank sectors can be enabled. You can edit the minimum and maximum limits of each blank sector; this will determine how much of the radar display is hidden.

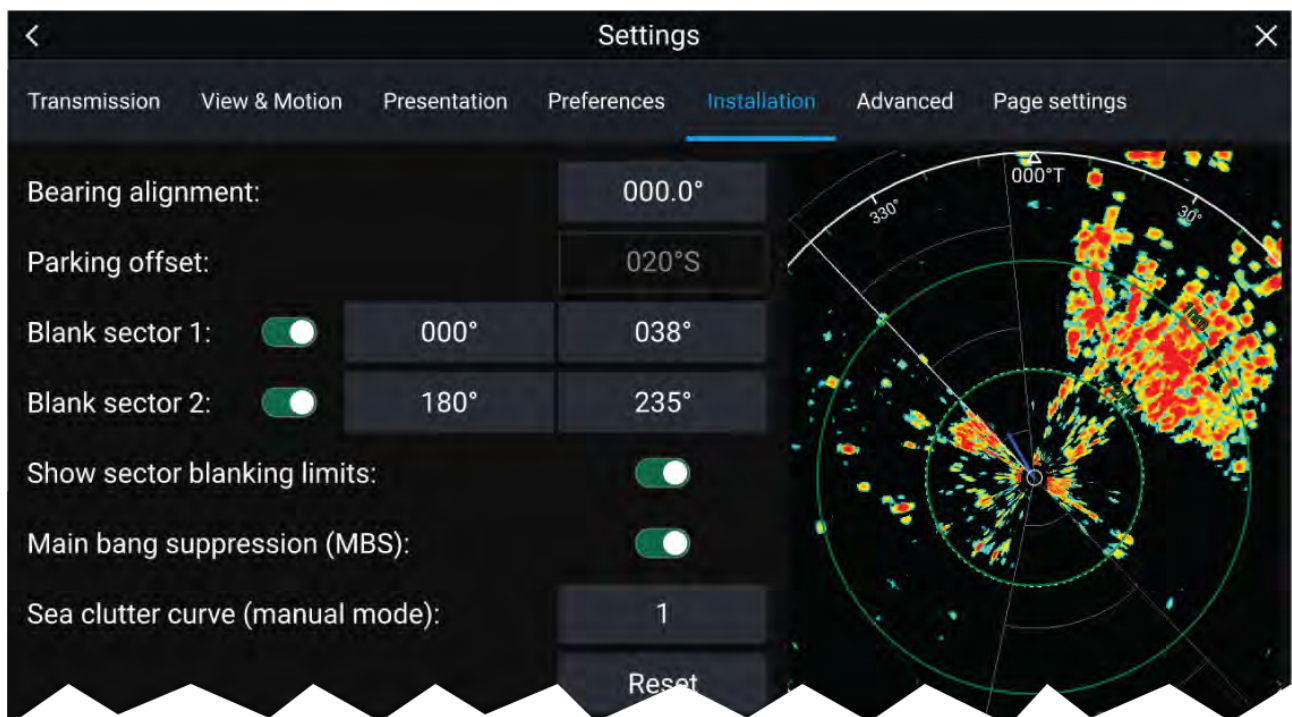

Blank sectors can be enabled / disabled on the radar overlay in the Chart app: **Chart app > Settings menu > Radar settings**

For more information refer to [Radar settings](#)

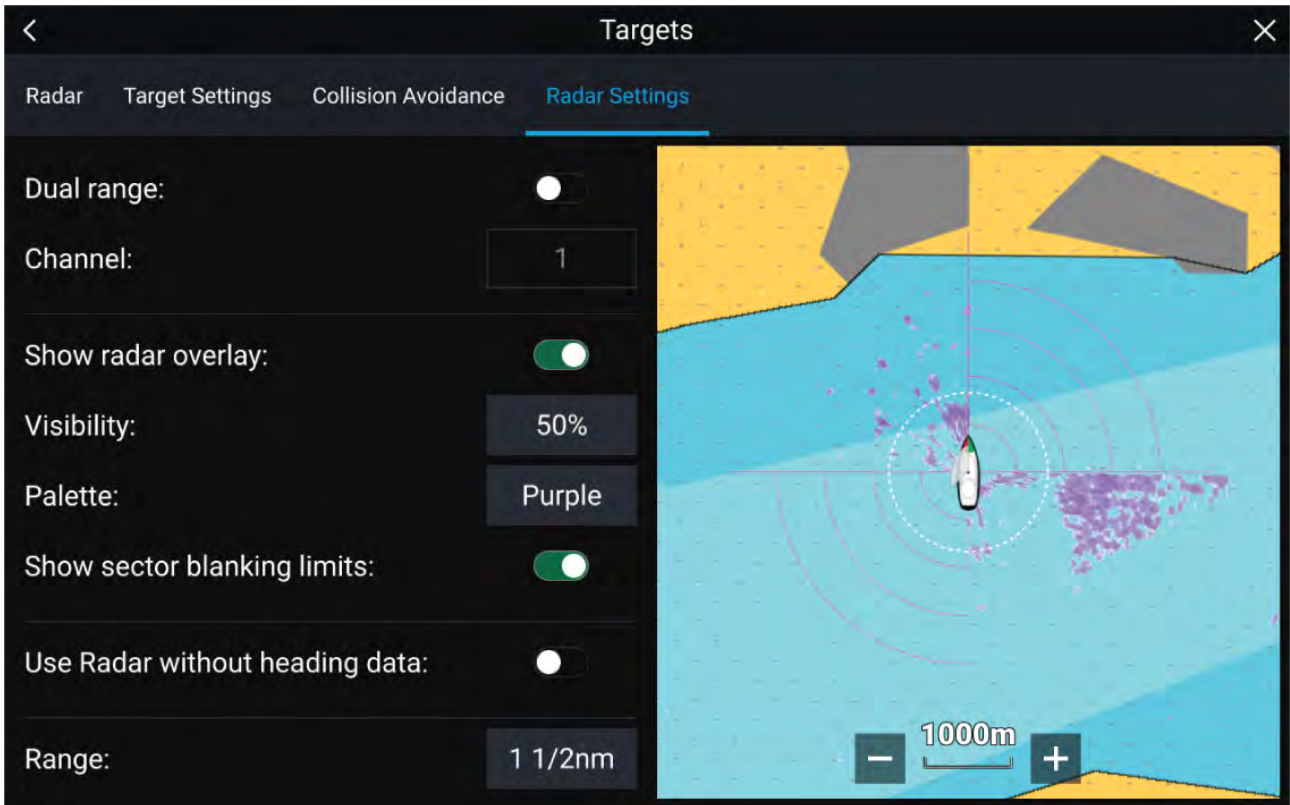



11.13 Radar sensitivity controls



Optimum performance is usually achieved using the default settings. You can adjust the image using the Sensitivity controls to improve the displayed image.



Sensitivity settings can be accessed using the onscreen **Image adjustment** icon, or the Adjust sensitivity menu option: **Menu > Adjust sensitivity**.

The Sensitivity controls available are dependant upon the Radar scanner in use.

Control	Name	Description
	'G' Gain	The control determines the signal strength at which target returns are shown onscreen. The Gain control can be set to Auto or Manual . A higher value produces more target returns and noise onscreen.
	'R' Rain	Precipitation appears on the Radar screen as lots of small echoes which continuously change size, intensity and position. The Rain control suppresses these echoes making it easier to identify real object. The higher the Rain control is set the more echoes will be suppressed.

Control	Name	Description
	'S' Sea	Radar echoes from waves can clutter the Radar screen. The Sea control suppresses these echoes (for up to 5 nm depending on conditions) making it easier to identify real objects. The higher the Sea control is set the more echoes will be suppressed.
	'CG' Color Gain	The control sets the lower limit for the color used for the strongest target returns. All target returns above this value are displayed in the strongest color. Those with a weaker value are divided equally between the remaining colors. The control can be set to Auto or Manual .
	All to Auto	Sets all Sensitivity settings to Auto with 0% offset.

11.14 Radar settings

The Settings menu provides access to the Radar app's features and functions. The options available in the Settings menu are dependent on the type of Radar scanner connected.

Transmission tab

Settings	Description	Options
Scanner	Allows you to select the Radar scanner that you want to use.	List of available Radar scanners.
Dual range	Enables and Disables dual range.	<ul style="list-style-type: none"> • On • Off
Channel	Determines which channel is shown in the Radar app.	<ul style="list-style-type: none"> • Channel 1 • Channel 2
Antenna size selection	Open Array Radar antenna size selection.	<ul style="list-style-type: none"> • 4ft • 6ft
Timed transmit	Enables and disables Timed transmit. Timed transmit configures your Radar to transmit at periodic intervals to conserve power.	<ul style="list-style-type: none"> • On • Off
Standby	Determines the length of time the Radar is in Standby for in Time transmit mode.	<ul style="list-style-type: none"> • 3 min • 5 min • 10 min • 15 min
Transmit	Determines the amount of scans the Radar will perform when transmitting in Time transmit mode..	<ul style="list-style-type: none"> • 10 scans • 20 scans • 30 scans

View & Motion tab

Settings	Description	Options
Orientation	<p>Head-up The top of the screen always points towards your vessel's current heading and as your heading changes the Radar image rotates accordingly. In Head-up the motion mode is fixed to Relative motion.</p> <p>North-up The top of the screen always points towards north and as your vessel's heading changes the SHM rotates accordingly.</p> <p>Course-up In Course-up the top of the screen always points towards your destination and as your heading changes the SHM rotates accordingly.</p>	<ul style="list-style-type: none"> • Head-up • North-up • Course-up
Motion mode	<p>Relative motion The position of your vessel remains fixed onscreen and the Radar image moves relative to your position. In Relative motion mode you can adjust your vessel's onscreen position using the Boat position setting.</p> <p>True motion Stationary Radar targets remain fixed and moving targets, including your vessel, move in true perspective to each other and to landmass. As your vessel's position reaches the edge of the screen, the image is redrawn to reveal the area ahead. In True motion mode the boat position is fixed to Full offset.</p>	<ul style="list-style-type: none"> • Relative motion • True motion
Boat position	<p>The boat position determines the position of your vessel onscreen. You can adjust the Boat position to provide a greater distance ahead of your vessel. Your boat position can only be changed in Relative motion mode.</p>	<ul style="list-style-type: none"> • Center • Partial offset • Full offset

Presentation tab

Settings	Description	Options
Range rings	Enables and disables Range rings in the Radar app.	<ul style="list-style-type: none"> • On • Off
Range ring labels	Enables and disables Range ring distance labels in the Radar app.	<ul style="list-style-type: none"> • On • Off
Color palette	Allows selection of the color palette.	List of color palettes.

Preferences tab

Settings	Description	Options
VRM/EBL reference	Determines the reference point used for VRM/EBLs.	<ul style="list-style-type: none"> • True/Mag • Relative
Interference rejection	Suppresses interference from other close by Radar scanners.	<ul style="list-style-type: none"> • On • Off

Settings	Description	Options
Interference rejection level	Determines the level of suppression used. Only available when Interference rejection is enabled.	Quantum™ <ul style="list-style-type: none"> Level 1 to Level 5 Non-HD Digital Radomes <ul style="list-style-type: none"> Normal High
Target expansion	When enabled, increases the Radar pulse length to provide larger target returns.	<ul style="list-style-type: none"> On Off
Expansion level	Determines the level of expansion used. Only available when Target expansion is enabled.	<ul style="list-style-type: none"> Low High
Tune adjust	Allows you to adjust the Radar scanners receiver for maximum target returns. It is recommended that the Radar scanner is allowed to warm up for at least 10 minutes prior to making adjustments.	<ul style="list-style-type: none"> Auto Manual (0% to 100%)
Radar speed	Allows you to select the appropriate rotation speed for your range. The Auto option provides an increased refresh rate at Radar ranges up to 3 nm.	<ul style="list-style-type: none"> 24 RPM Auto (24 / 48 RPM)
Transmit frequency	Changing the Transmit frequency can reduce interference on the Radar image.	<ul style="list-style-type: none"> Low Normal High

Installation tab

Under normal circumstances it should not be necessary to adjust Installation settings.

Settings	Description	Options
Bearing alignment	Enables you to align the Radar image correctly in relation to your vessel's bow.	<ul style="list-style-type: none"> 179.5° Port to 180° Starboard
Parking offset	Allows you to select the "parked" position of your Open Array's antenna. This feature is only available when the Open Array radar scanner is in Standby.	<ul style="list-style-type: none"> 0° to 359°
Blank sector 1	Allows you to hide a specific section of the radar display, creating a "blank" sector onscreen that shows no radar signal returns. <div style="border: 1px solid black; padding: 5px;"> <p>Note: Sector blanking is only compatible with Magnum Open Array radars and Lighthouse software version 3.9 or later.</p> </div>	<ul style="list-style-type: none"> 0° to 359° 0° to 10° (default)
Blank sector 2	Allows you to hide an additional section of the radar display, creating a "blank" sector onscreen that shows no radar signal returns. <div style="border: 1px solid black; padding: 5px;"> <p>Note: Sector blanking is only compatible with Magnum Open Array radars and Lighthouse software version 3.9 or later.</p> </div>	<ul style="list-style-type: none"> 0° to 359° 180° to 190° (default)

Settings	Description	Options
Main Bang Suppression (MBS)	MBS eliminates saturation immediately around your vessel. When adjusting Zero range it is recommended that MBS is set to Off.	<ul style="list-style-type: none"> • Off • On
Sea clutter curve	Adjusts the Radar scanner's sensitivity to Sea clutter.	<ul style="list-style-type: none"> • 1 to 8

Advanced tab

Under normal circumstances it should not be necessary to adjust Advanced settings.

Settings	Description	Options
Tune preset	Radar tuning is controlled either automatically or manually, using the Tune adjust setting. Tune preset controls the range available to the Tune adjust control.	<ul style="list-style-type: none"> • 0 to 255
STC preset	The Sensitivity Time Control (STC) can be used to equalize targets across the image. If you find targets are brighter or dimmer nearer the center of the image adjust the STC preset until the desired result is achieved.	<ul style="list-style-type: none"> • 0% to 100%
Zero range	Zero range (Display timing) is used to configure the zero range of the Radar scanner so that objects appear at the correct distance.	<ul style="list-style-type: none"> • 0 to 153m / 502ft
Reset	Resets Installation and advanced settings to factory defaults.	<ul style="list-style-type: none"> • Yes • No

Page settings tab

Settings	Description
Data Overlays	Enables configuration of Data overlays
Edit split ratio	Enables you to customize the position of the partitions in splitscreen app pages.

Chapter 12: Dashboard app

Chapter contents

- [12.1 Dashboard app overview on page 232](#)
- [12.2 Default data pages on page 233](#)
- [12.3 Customizing existing Data pages on page 234](#)
- [12.4 Dashboard settings menu on page 238](#)
- [12.5 Navigation and Sailing dials on page 241](#)

12.1 Dashboard app overview

The Dashboard app enables you to view system data. System data may be generated by your MFD or by devices connected to your MFD via SeaTalkng® / NMEA 2000 and SeaTalkhs™. The Dashboard app can also be configured to provide control of your compatible Digital Switching devices.

Note: For data to be available in the Dashboard app it must be transmitted to your MFD from compatible hardware using supported protocols and messages.





The Dashboard app can be displayed in Fullscreen and half screen portrait app pages.



For each instance of the Dashboard app you can select which Data pages you want to use, the Data page selection will persist over a power cycle.



The Dashboard app is pre-configured with a number of customizable data pages.

Dashboard app controls

Icon	Description	Function
	Home icon	Takes you to the Homescreen.
	Waypoint / MOB	Place waypoint / activate Man overboard (MOB) alarm.
	Pilot icon	Opens and closes the Pilot Sidebar
	Menu icon	Opens the app menu.

Icon	Description	Function
	Left arrow	Displays the previous data page.
	Right arrow	Displays the next data page.

Switching data page

1. Use the **Left arrow** and **Right arrow** buttons, located at the bottom of the screen, to cycle through the available data pages.
2. Alternatively, you can select a specific data page from the Dashboard app menu.

Selecting Data pages to display

For each instance of the Dashboard app you can select which Data pages you want to be able to view.

1. Select the **Pages** tab: **Menu > Settings > Pages**.
2. Select the relevant page from the list.
3. Select **Hide page** from the pop-over options.

The selected page will no longer be available in the current instance of the Dashboard app.

*Selecting **Show page** for a hidden page will include the page in the app instance again.*

12.2 Default data pages

The Dashboard app comes with a selection of default data pages:

- Engines
- Sailing (only shown if boating activity is set to Sailing in startup wizard)
- Race start (only shown if boating activity is set to Sailing in startup wizard)
- Navigation
- Rolling road with data
- Tanks
- Bidata
- Single data
- Fuel

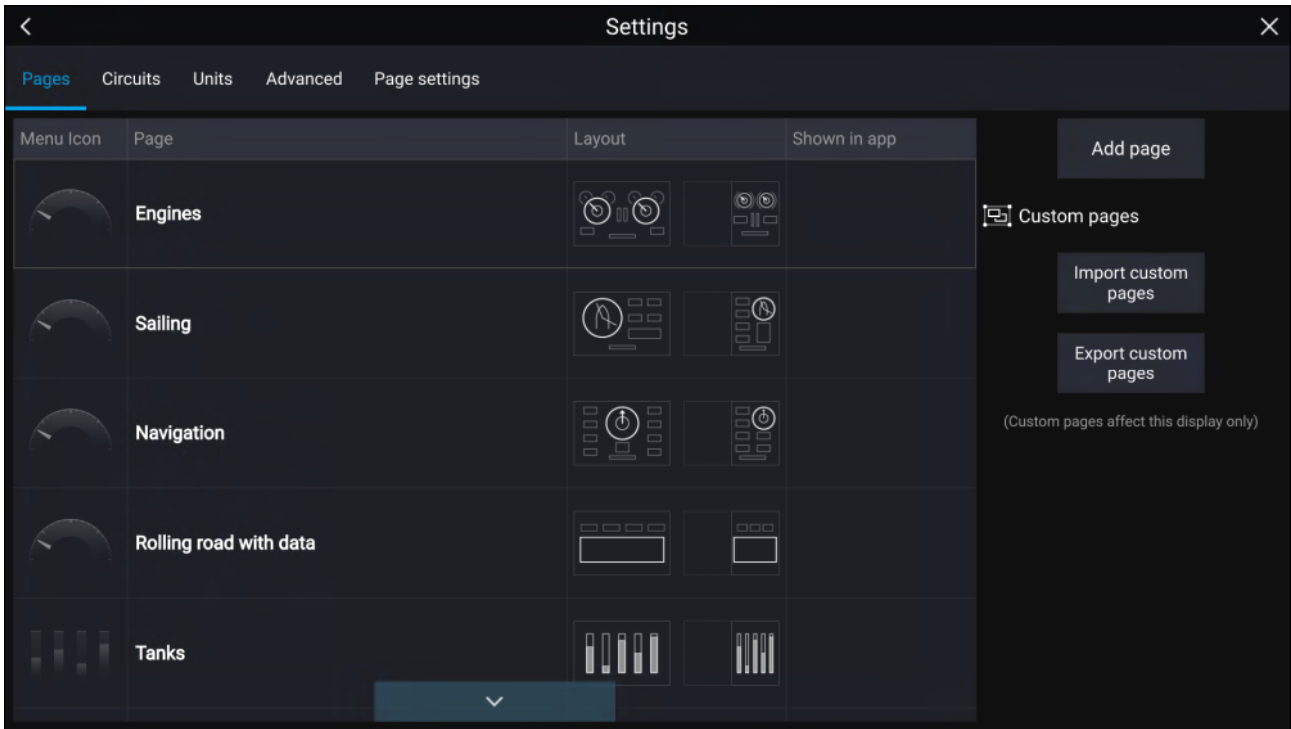

The displayed data items on each of these pages can be customized.

12.3 Customizing existing Data pages

The data items displayed on each page can be changed.

1. Select and hold on the relevant Data item.
2. Select **Edit** from the Data item pop-over menu.
3. Select the new Data item that you want to display.

Alternatively you can select **Customize page** from the app menu: **Menu > Customize page**.

Available data items

The data items listed below can be added to a Dashboard data page or to an app's Data overlay.

Data type	Data item	Notes
Battery	<ul style="list-style-type: none"> • Temperature • Voltage • Current 	<ul style="list-style-type: none"> • Data items available for up to 5 batteries.
Boat	<ul style="list-style-type: none"> • Mast rotation • Live Well • Black Water • Gray Water • Fresh Water • Roll • ROT (Rate Of Turn) 	
Depth	<ul style="list-style-type: none"> • Maximum Depth • Minimum Depth • Depth 	

Data type	Data item	Notes
Distance	<ul style="list-style-type: none"> • Distance to line • Distance to tack • Trip season • Trip month • Trip day • Trip manual • Ground Trip 4 • Ground Trip 3 • Ground Trip 2 • Ground Trip 1 • Ground Log • Trip • Log • Line bias 	<ul style="list-style-type: none"> • Distance to line, Distance to tack and Line bias are only available with sailing vessels.
Engine	<ul style="list-style-type: none"> • ECO Mode • Transmission Oil Temperature • Transmission Oil Pressure • Fuel Pressure • Average Fuel Rate • Instantaneous Fuel Economy • Engine Fuel Rate • Engine Tilt • Engine Hours • Engine Load • Coolant Temperature • Coolant Pressure • Alternator • Oil Pressure • Oil Temperature • Boost Pressure • RPM (Revolutions Per Minute) • RPM Engine Hours 	<ul style="list-style-type: none"> • Data items available for up to 5 engines.
Fuel	<p>For tanks 1 to 5:</p> <ul style="list-style-type: none"> • Fuel Economy • Fuel Rate (Total) • TTE (Time To Empty) • DTE (Distance To Empty) • Est. Fuel Level • Season Fuel • Total Trip Fuel • Trip Fuel 	<ul style="list-style-type: none"> • Data items available for up to 5 fuel tanks. • An 'All tanks' category is also available which combines data from all fuel tanks.

Data type	Data item	Notes
	<ul style="list-style-type: none"> • Est. Fuel • Fuel Level <p>For All tanks:</p> <ul style="list-style-type: none"> • Engine economy total • Fuel flow total • Time to empty • Distance to empty • Fuel used (season) • Fuel used (trip) • Est. fuel remaining 	
Environment	<ul style="list-style-type: none"> • Humidity • Pressure • Drift from position • Apparent Wind Chill • True Wind Chill • Dew Point • Maximum Air Temperature • Minimum Air Temperature • Air Temperature • Maximum Water temperature • Minimum Water Temperature • Water Temperature • Set • Drift • Set & Drift 	
GPS	<ul style="list-style-type: none"> • COG (Course Over Ground) • Average SOG • Maximum SOG • SOG (Speed Over Ground) • Position • COG & SOG 	
Heading	<ul style="list-style-type: none"> • Steer to layline • Locked Heading Error • Track Heading • Locked Heading • Heading • Locked Heading & Locked Heading Error • Heading & STW (Speed Through Water) 	<ul style="list-style-type: none"> • Steer to layline is only available with sailing vessels

Data type	Data item	Notes
Navigation	<ul style="list-style-type: none"> • BOTW (Bearing Origin To Waypoint) • XTE (Cross Track Error) • Next waypoint name • Original target distance • Next turn angle • Route ETA (Estimated Time of Arrival) • Route TTG (Time To Go) • Waypoint • Waypoint TTG • Target position • VMG (Velocity Made Good) to Waypoint • Waypoint ETA (Estimated Time of Arrival) • DMG (Distance Made Good) • CMG (Course Made Good) • DTW (Distance To Waypoint) • XTE (Cross Track Error) • BTW (Bearing To Waypoint) • Compass • CMG & VMG to Waypoint (Course Made Good & Velocity Made Good) • CMG & DMG (Course Made Good & Distance Made Good) • BTW & DTW (Bearing To Waypoint and Distance To Waypoint) 	
Speed	<ul style="list-style-type: none"> • Polar performance • VMG to Wind • Average STW (Speed Through Water) • Maximum STW (Speed Through Water) • STW (Speed Through Water) 	<ul style="list-style-type: none"> • Polar performance is only available with sailing vessels
Time	<ul style="list-style-type: none"> • Sunset Time • Sunrise Time • UTC Date • UTC (Universal Time Coordinated) Time • Race Timer • Local Time • Local Date • Time to burn • Time to tack 	<ul style="list-style-type: none"> • Race timer, Time to burn, Time to tack are only available with sailing vessels • Race timer can be used to start, stop and edit the countdown timer
Wind	<ul style="list-style-type: none"> • Cardinal Wind • Beaufort • GWD (Ground Wind Direction) • GWS (Ground Wind Speed) 	

Data type	Data item	Notes
	<ul style="list-style-type: none"> • TWD (True Wind Direction) • Minimum TWA (True Wind Angle) • Maximum TWA (True Wind Angle) • TWA (CH) (Close Hauled) • TWA (True Wind Angle) • Maximum TWS (True Wind Speed) • Minimum TWS (True Wind Speed) • TWS (True Wind Speed) • Minimum AWA (Apparent Wind Angle) • Maximum AWA (Apparent Wind Angle) • AWA (CH) (Apparent Wind Angle, Close Hauled) • AWA (Apparent Wind Angle) • Minimum AWS (Apparent Wind Speed) • Maximum AWS (Apparent Wind Speed) • AWS (Apparent Wind Speed) • GWS & GWD (Ground Wind Speed & (Ground Wind Direction) • AWA & VMG to Wind (Apparent Wind Angle & Velocity Made Good) • AWA (CH) & AWS (Apparent Wind Angle, Close Hauled) & (Apparent Wind Speed) • AWA & AWS (Apparent Wind Angle, Close Hauled) & (Apparent Wind Speed) • TWA & VMG to Wind (True Wind Angle & Velocity Made Good) • TWA (CH) & TWS (True Wind Angle (Close Hauled) & True Wind Speed) • TWA & TWS (True Wind Angle & True Wind Speed) • GWD & Beaufort (Ground Wind Direction) 	

12.4 Dashboard settings menu

Pages tab

The Pages tab provides a list of all available pages.

Settings	Description	Options
Page list	<p>Pop-over options allow you to customize the Dashboard app. You can rearrange pages, add new pages, rename existing pages or reset pages to default settings.</p> <div style="border: 1px solid black; padding: 5px; margin-top: 10px;"> <p>Note: * You can only delete pages added using the Add page option.</p> </div>	<ul style="list-style-type: none"> • Hide/Show page • Move up • Move down • Add page • * Delete page • Rename • Reset all
Add page	You can add new dashboard pages that you can customize by selecting Add page .	Displays pop-over with page layouts.
Import custom pages	You can import digital switching pages . Please refer to Raymarine Product support for more details.	Displays file browser
Export custom pages	<p>You can export your digital switching pages so that they can be restored at a later date. You must use this feature if you wish to export or backup your digital switching pages, as digital switching pages are not included in the standard MFD “Backup and restore” process, which is used to backup user settings only. Please refer to Raymarine Product support for more details.</p> <p>Exporting digital switching pages must be performed on each MFD configuration.</p>	Save dialog

Circuits tab

Settings	Description	Options
List of tripped channels	In Digital Switching systems, the circuit tab provides a list of tripped channels. Tripped circuits can be acknowledged and reset from the pop-over options.	<ul style="list-style-type: none"> • Acknowledged • Reset

Units tab

Measurement	Units
Distance units	<ul style="list-style-type: none"> • Nautical Miles • NM & m • Statute Miles • Kilometers
Speed units	<ul style="list-style-type: none"> • Kts • MPH • KPH
Depth units	<ul style="list-style-type: none"> • Meters • Feet • Fathoms
Temperature units	<ul style="list-style-type: none"> • Celsius • Fahrenheit

Measurement	Units
Date format	<ul style="list-style-type: none"> • MM:DD:YYYY • DD:MM:YYYY • MM:DD:YY • DD:MM:YY
Volume units	<ul style="list-style-type: none"> • US Gallons • Imperial Gallons • Liters
Economy units	<ul style="list-style-type: none"> • Distance per Volume • Volume per Distance • Liters per 100 km
Wind speed units	<ul style="list-style-type: none"> • Knots • Meters per Second
Pressure units	<ul style="list-style-type: none"> • Bar • PSI • Kilopascals
Time format	<ul style="list-style-type: none"> • 12hr • 24hr

Settings	Description	Options
Bearing mode	Determines how bearing and heading data is displayed.	<ul style="list-style-type: none"> • True • Magnetic
System Datum	Determines the datum used by your MFD. This should be set to the same datum used by your paper charts.	List of available datums.
Variation	When set to Auto the MFD will automatically compensate for the naturally-occurring offset of the Earth's magnetic field.	<ul style="list-style-type: none"> • Auto • Manual
Manual variation	When variation is set to Manual , you can specify an offset.	<ul style="list-style-type: none"> • 30° W to 30° E

Advanced tab

Settings	Description	Options
Maximum RPM	You can select a maximum RPM for your engine dials, or allow the system to automatically configure the Maximum RPM.	<ul style="list-style-type: none"> • Auto • 3,000 RPM to 10,000 RPM
Custom RPM Red zone	You can create a custom Red zone for your RPM dials.	<ul style="list-style-type: none"> • 0 RPM to 10,000 RPM
Wind angle response	You can configure the rate at which Wind angle data is updated on the MFD. The Higher the response setting the faster the update rate will be.	<ul style="list-style-type: none"> • 1 to 15
Wind speed response	You can configure the rate at which Wind speed data is updated on the MFD. The Higher the response setting the faster the update rate will be.	<ul style="list-style-type: none"> • 1 to 15

Page settings tab

Settings	Description
Data Overlays	Enables configuration of Data overlays
Edit split ratio	Enables you to customize the position of the partitions in splitscreen app pages.

12.5 Navigation and Sailing dials

Navigation and Sailing dials are available which provide a compass dial with various data indicators.

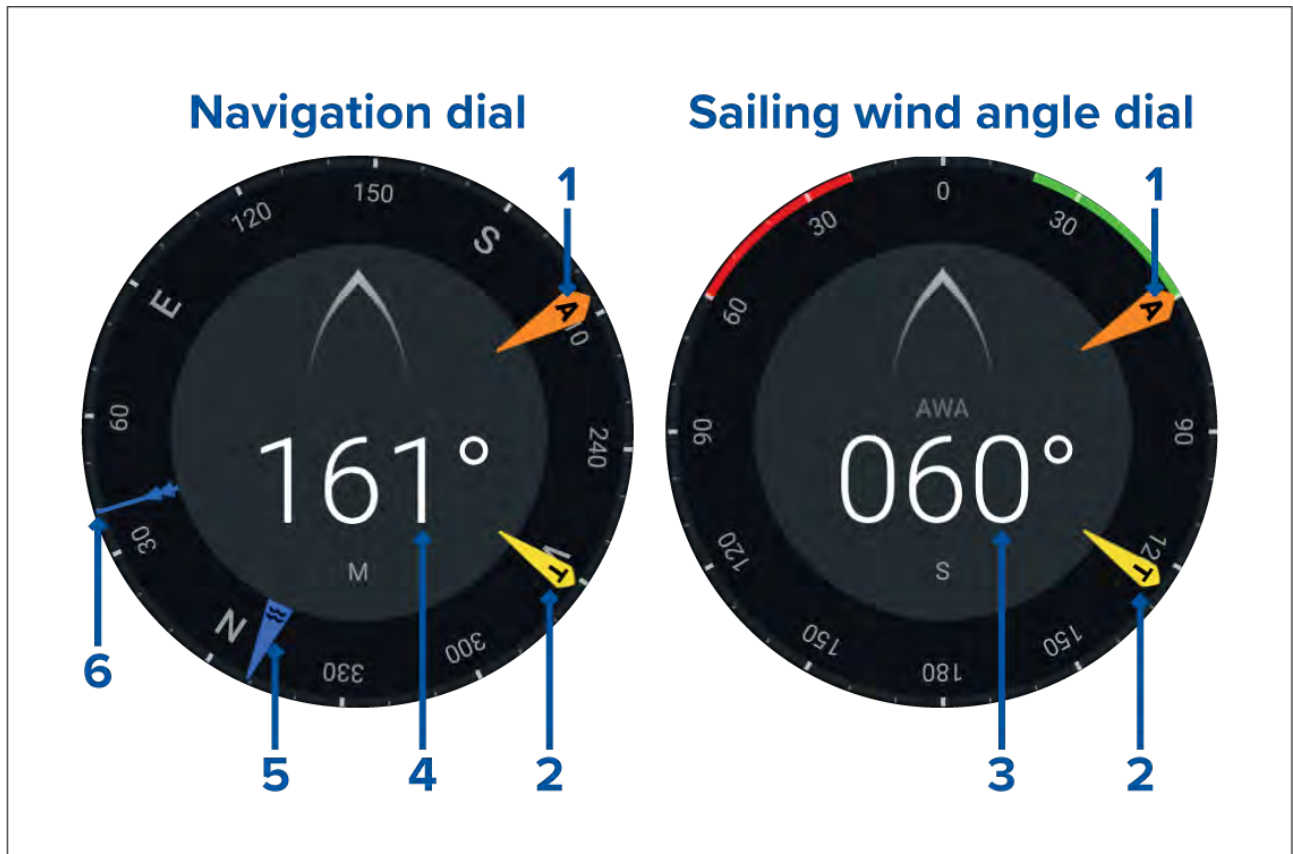

1. Apparent Wind Angle (AWA) indicator
2. True Wind Direction (TWD) indicator
3. Apparent Wind Angle (AWA)
4. Heading
5. Tide direction indicator
6. Course Over Ground (COG) indicator

Sailing dials for laylines

The Sailing page and Navigation page can display an Apparent wind or True wind dial to aid with sailing along laylines.

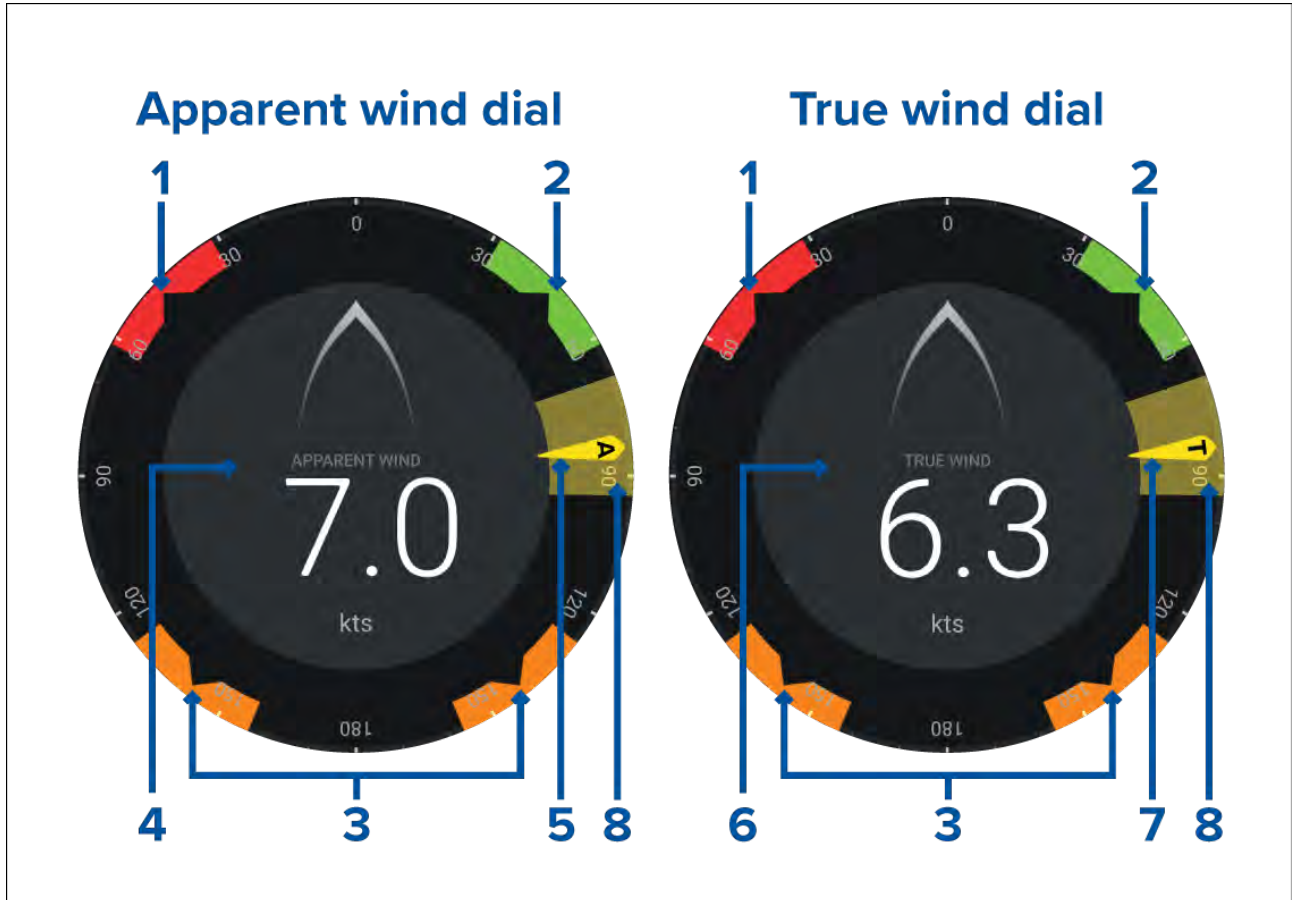

1. Port wind angle target
2. Starboard wind angle target
3. Downwind wind angle target
4. Apparent wind speed
5. Apparent wind angle
6. True wind speed
7. True wind angle
8. Historical wind angle

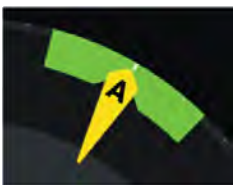

When sailing you may aim the wind angle so it aligns with the centre of the wind angle target to maximise your velocity made good (VMG) when tacking upwind or gybing downwind.

Sailing data items

The default sailing page comes with a selection of data items designed to help with sailing:

- Apparent wind sailing dial
- Distance to tack
- Time to tack
- Sailing distance to waypoint
- Waypoint sailing Time To Go
- Speed through water
- Target speed through water

- Steer to layline
- Polar performance (only active with sailing profile set to polar)
- Rudder bar

It is advised to use the Sailing data items in combination with the Laylines feature available in the **Chart app**. For more information refer to: [8.4 Laylines](#)

Race Start data items

The Race Start page comes with a selection of data items designed to help achieve a better racing start:

Note:
Lighthouse software version 3.10 is required.

- Apparent wind sailing dial
- Race Timer (can be used to start, stop and edit the countdown timer)
- Distance to line
- Line bias
- Time to burn
- Time

It is advised to use the Race Start data items in combination with the Laylines feature and the Race Start and Race Timer features available in the **Chart app**. For more information refer to:

[8.4 Laylines](#)

[8.5 Race Start Line \(SmartStart\) and Race Timer](#)

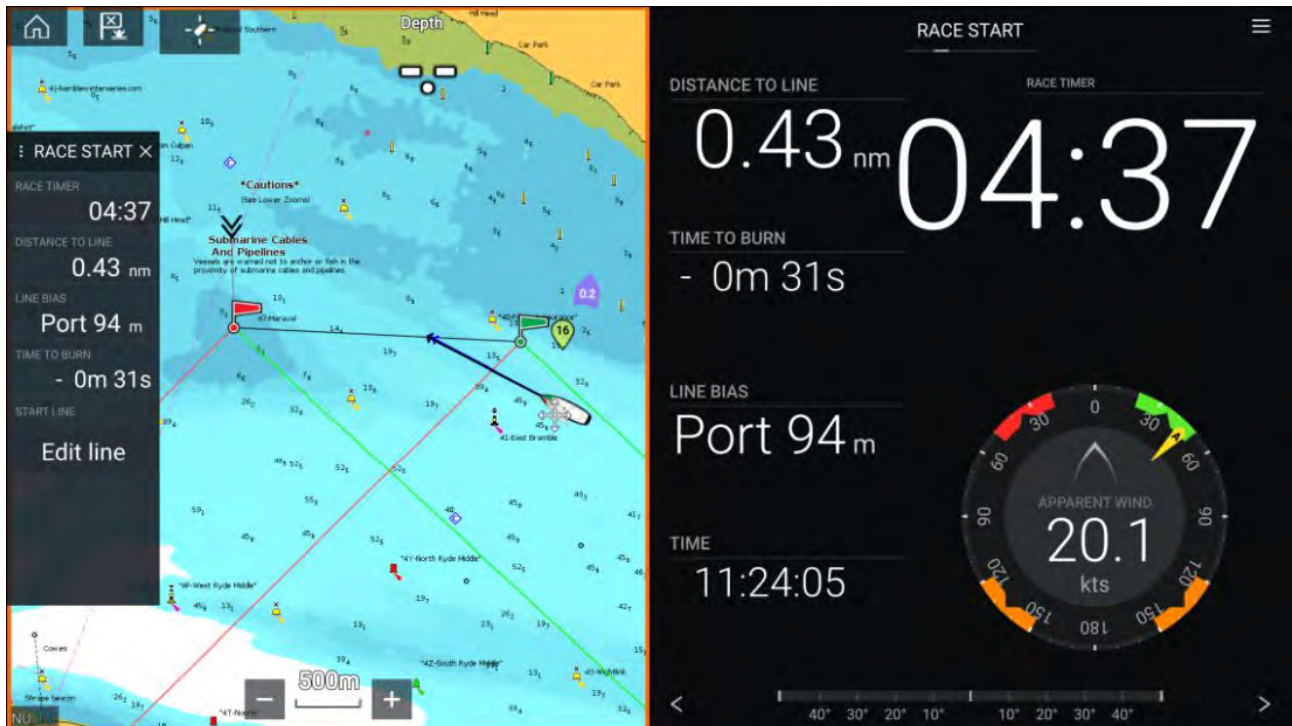

Chapter 13: Yamaha app

Chapter contents

- [13.1 Yamaha app overview on page 246](#)
- [13.2 Customizing Data pages on page 247](#)
- [13.3 Engine page on page 251](#)
- [13.4 Settings on page 256](#)

13.1 Yamaha app overview

The **Yamaha app** enables you to view engine system data from a connected Yamaha Command Link or Command Link Pro network.

Note:

- The Yamaha app will only display data when a compatible Yamaha Command Link or Command Link Pro network is connected to the MFD via a Yamaha NMEA 2000 gateway or CL7 gauge.
- The Yamaha app can only be displayed as a Fullscreen app page.
- The Yamaha app is pre-configured with a number of customizable data pages.
- For each instance of the Yamaha app you can select which Data pages you want to use; the Data page selection will persist over a power cycle.

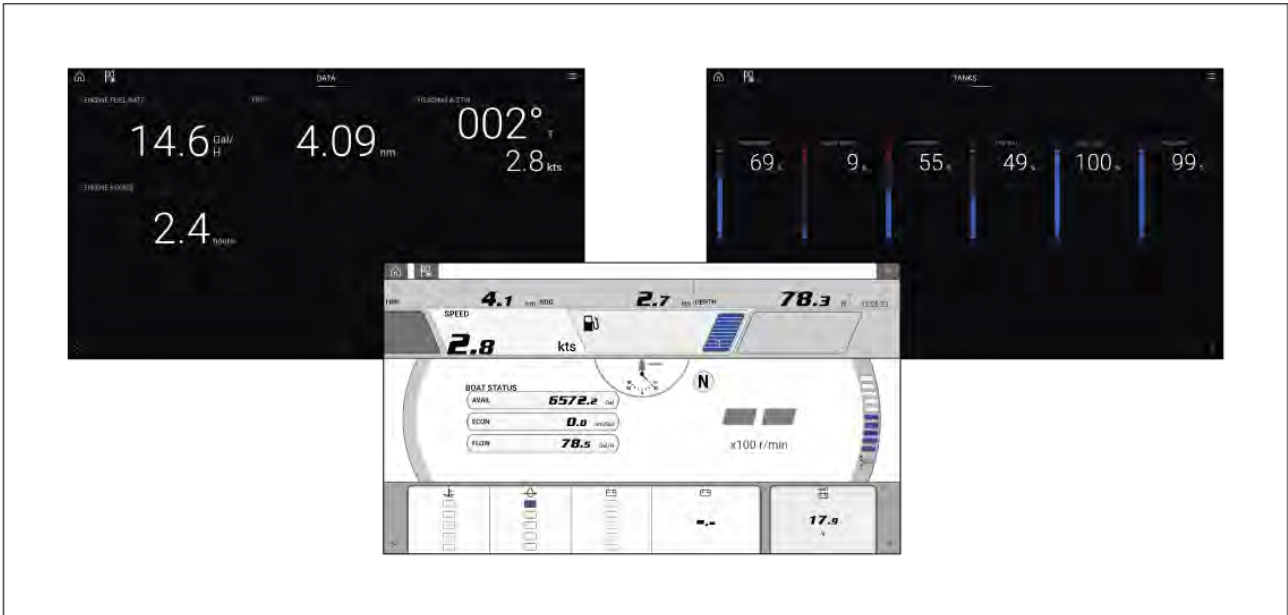

Requirements



The Yamaha app features are enabled (unlocked) when the following requirements are met:



- A compatible Yamaha Command Link or Command Link Pro network is connected to the MFD via a Yamaha NMEA 2000 gateway (6YG-8A2D0-00-00) or CL7 Gauge.
- Your MFD must be running LightHouse 3 version 3.9 or above.

Note:

Do not use a Gateway module (6YG-8A2D0-00-00) and CL7 Gauge together on the same network.

Yamaha app controls

Icon	Description	Function
	Home icon	Takes you to the Homescreen.
	Waypoint / MOB	Place waypoint / activate Man overboard (MOB) alarm.
	Pilot icon	Opens and closes the Pilot Sidebar

Icon	Description	Function
	Menu icon	Opens the app menu.
	Left arrow	Displays the previous data page.
	Right arrow	Displays the next data page.

Switching data page

1. Use the **Left arrow** and **Right arrow** buttons, located at the bottom of the screen, to cycle through the available data pages.
2. Alternatively, you can select a specific data page from the Yamaha app menu.

13.2 Customizing Data pages

The Yamaha App contains 3 default data pages: **Engines**, **Data** and **Tanks**. The data items displayed on each page can be changed, hidden or reset.

To customize each page:

1. Select and hold the relevant Data item.
 - i. Alternatively you can select **Customize page** from the app menu: **Menu > Customize page**.
2. Select **Edit**, **Hide** or **Reset** from the Data item pop-over menu.
 - i. **Edit** — you can select the new data item you want to add to the page.
 - ii. **Hide** — removes the data item from the page.
 - iii. **Reset** — reset the value of the selected data item (only available for certain data items).

Available data items

Engine page

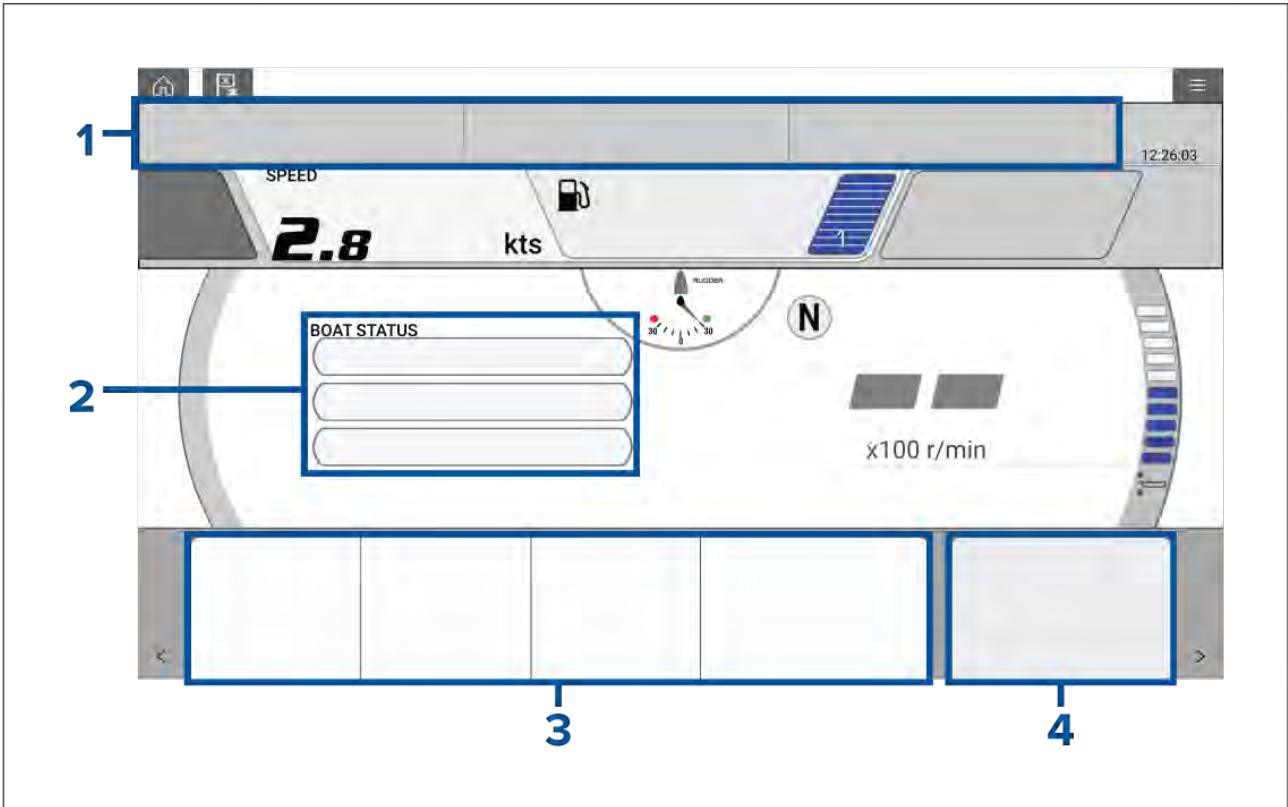

Cell 1 and Cell 2			
Data type	Data item	Data type	Data item
Depth	• Depth	Environment	• Water Temp
Distance	• Trip	GPS	• SOG
Engine	• Engine Trip Hours • Engine Hours	Pilot	• Rudder
Fuel	• Engine economy total • Fuel flow total • Fuel used (trip) • Est. fuel remaining	Speed	• STW
Cell 3		Cell 4	
Data type	Data item	Data type	Data item
Engine	• Coolant Temp • Coolant Pres • Alternator Level • Alternator • Oil Pres	Boat	• Accessory voltage level • Accessory voltage • Supply voltage level • Supply voltage

Data Page



Data type	Data item	Data type	Data item
Battery	<ul style="list-style-type: none"> • TTZ • SOC 	GPS	<ul style="list-style-type: none"> • COG • Avg SOG • Max SOG • SOG • Loran Position • Position • COG SOG
Boat	<ul style="list-style-type: none"> • Mast Rot • Roll • ROT 	Heading	<ul style="list-style-type: none"> • Lock Hdg Err • Tack Heading • Lock Hdg • Heading • Heading & STW
Depth	<ul style="list-style-type: none"> • Max Depth • Min Depth • Depth 	Navigation	<ul style="list-style-type: none"> • VMG to Wpt • BTW & DTW • CMG & VMG to WPT • Compass • BTW • XTE • DTW • CMG • DMG • Wpt ETA • TTP • Target Pos • Loran Target Pos

			<ul style="list-style-type: none"> • Wpt TTG • Wpt • Rte ETA • Next turn angle • Origin target distance • Next waypoint name • BOTW
Distance	<ul style="list-style-type: none"> • Trip season • Trip month • Trip day • Trip manual • Ground Log • Trip • Log 	Pilot	<ul style="list-style-type: none"> • Rudder
Engine	<ul style="list-style-type: none"> • RPM • Engine Trip Hours • Fuel Rate (Avg) • Inst Fuel Economy • Engine Fuel Rate • Engine Hours 	Speed	<ul style="list-style-type: none"> • VMG to Wind • Avg STW • Max STW • STW
Fuel	<ul style="list-style-type: none"> • Engine economy total • Fuel flow total • Time to empty • Distance to empty • Fuel used (season) • Total Trip Fuel • Fuel used (trip) • Est. fuel remaining 	Time	<ul style="list-style-type: none"> • Timer • Sunset Time • Sunrise Time • UTC Time • Local Time • UTC Date • Local Date • Tme and Timer
Environment	<ul style="list-style-type: none"> • Drift from ps • Wind Chill (App) • Wind Chill (True) • Dew Point • Max Air Temp • Min Water Temp • Water Temp • Set • Drift • Sunrise/Sunset • Set Drift 	Wind	<ul style="list-style-type: none"> • Max AWA • GWD + Beaufort • TWA & TWS • TWA (CH) & TWS • TWA & VMG to Wind • AWA & AWS • AWA (CH) & AWS • AWA & VMG to Wind • GWS & GWD • AWS • Max AWS • Min AWS • AWA • AWA (CH)

		<ul style="list-style-type: none"> • Cardinal Wind • Min AWA • TWS • Min TWS • Max TWS • TWA • TWA (CH) • Max TWA • Min TWA • TWD • GWS • GWD • Beaufort (wind force scale)
--	--	--

Tanks Page



Data type	Data item	Data type	Data item
Boat	<ul style="list-style-type: none"> • Fresh Water • Live Well • Gray Water • Black Water 	Fuel	<ul style="list-style-type: none"> • Total Fuel (vol) • Total Fuel • Fuel level

13.3 Engine page

In addition to the customizable data cells available, the Engine page also displays the following engine and tank data for your vessel:

- Rudder position (single engine only)
- Transmission
- Speed

- Revolutions Per Minute (r/min)
- Engine trim
- Number of fuel tanks and fill level

Troll mode can also be enabled from this page.

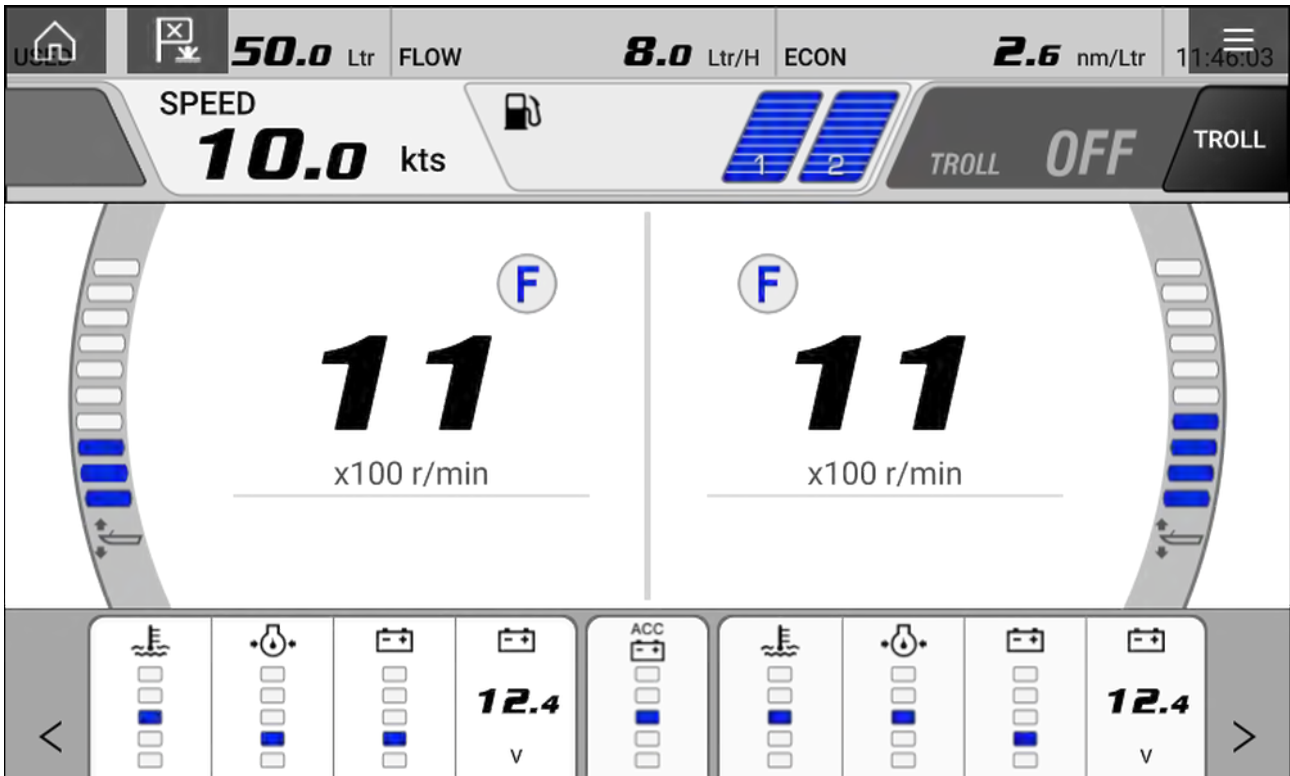

Engines

The number of Yamaha engines connected to your MFD's network determines how the engine page is displayed.

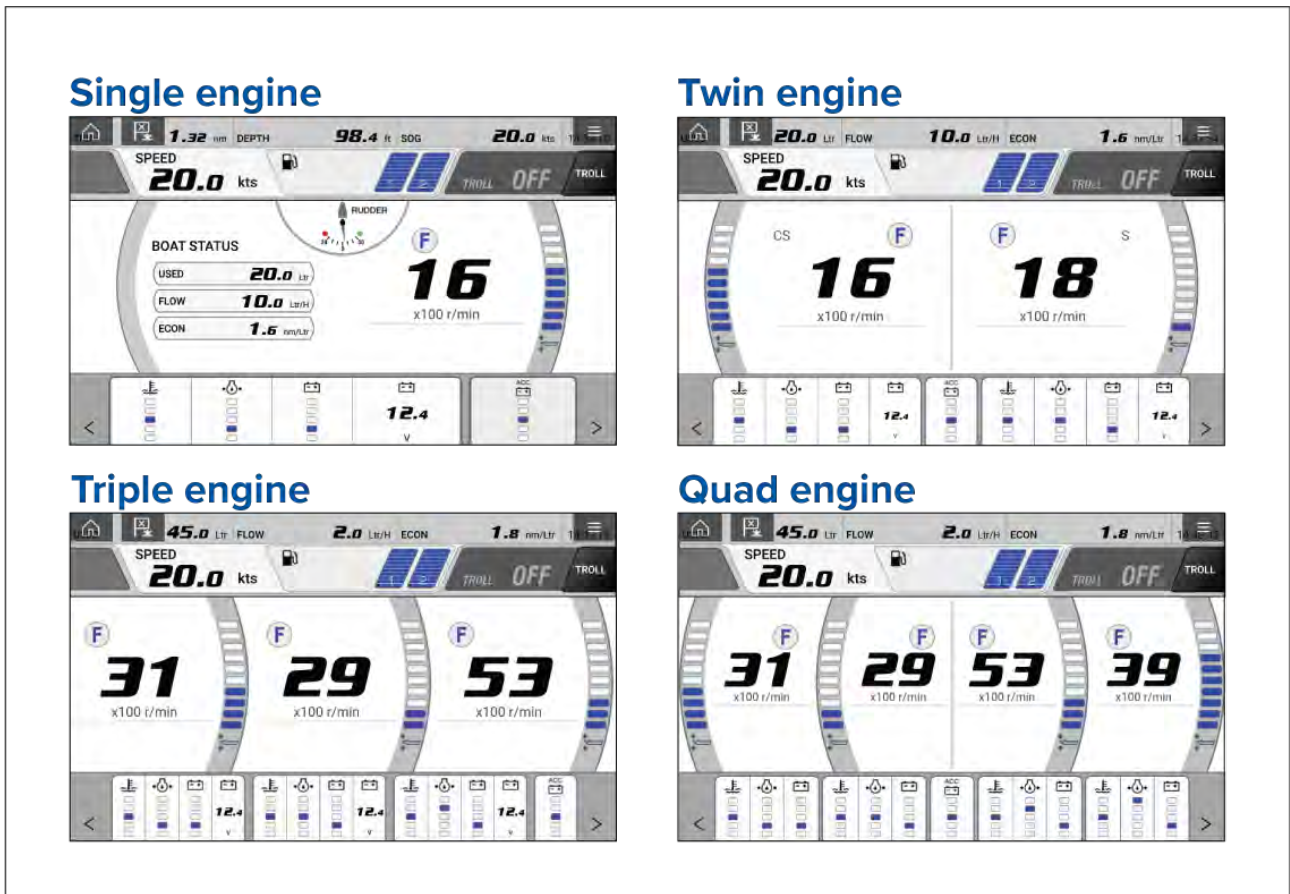

The number of engines and their manufacturer can be set on the **Boat details** page.

Homescreen > Settings > Boat details

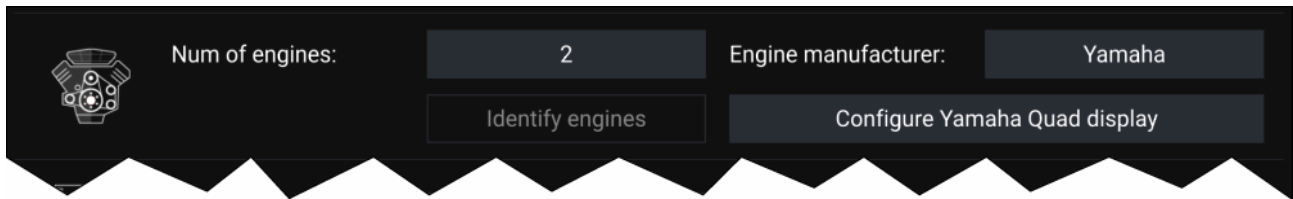

If your vessel is setup using the old quad engine system (2 MFDs for Port and Starboard Engines), you can select which engines are displayed per MFD by selecting **Configure Yamaha Quad display** and choosing **Port side** or **Starboard side**.

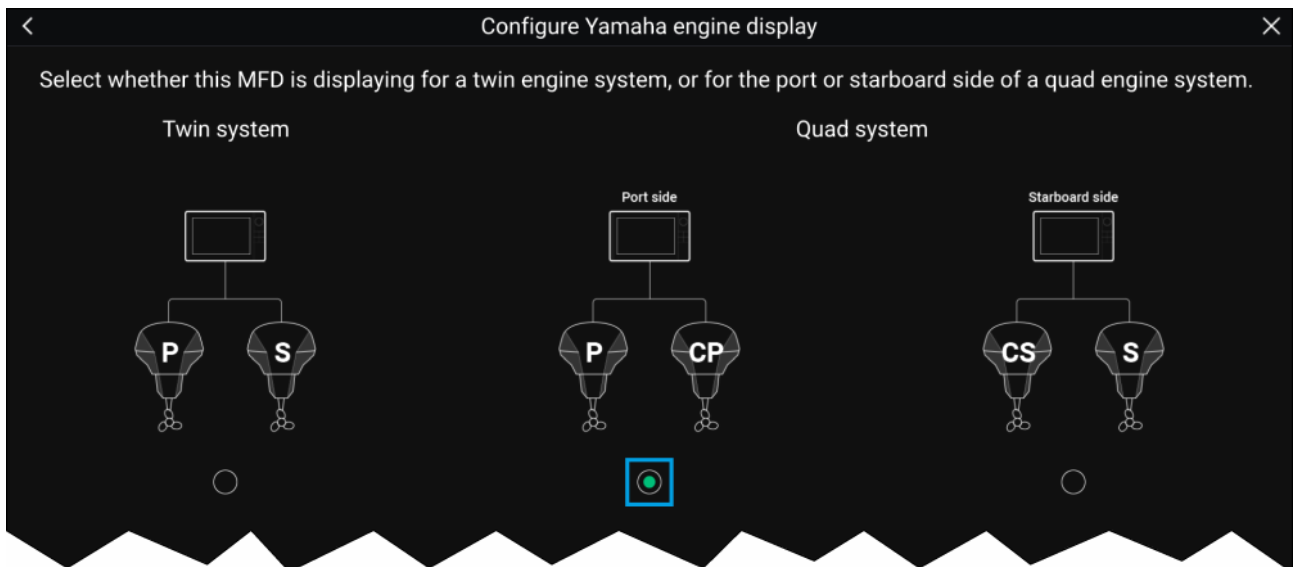

The engine page will update to reflect which engines your MFD is networked to, with Port and Central Port symbols or Starboard and Central Starboard symbols.

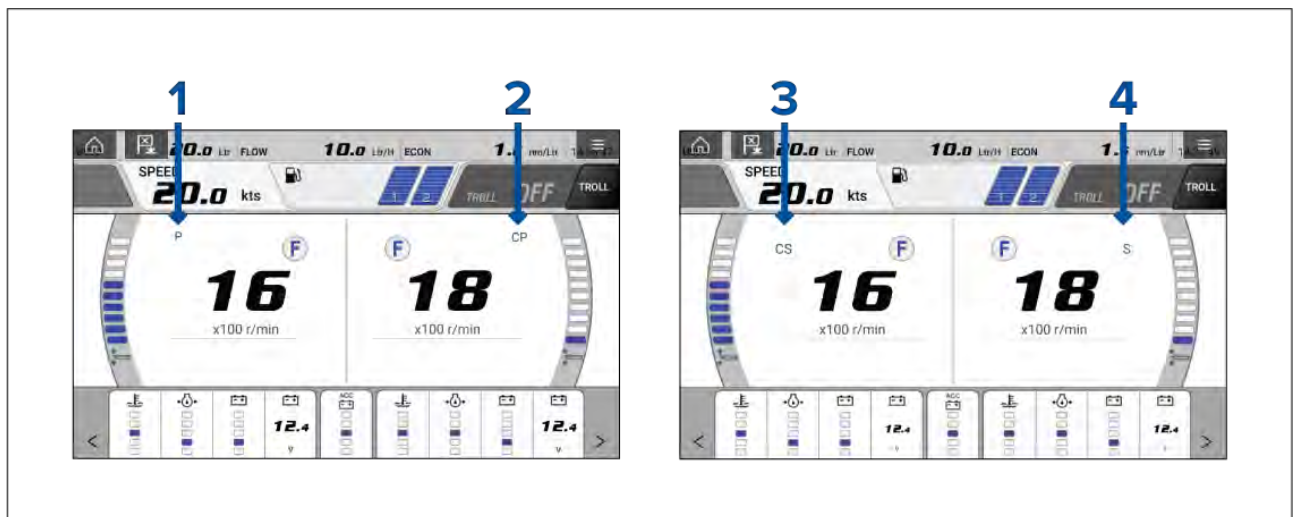

1. Port engine
2. Central Port engine
3. Central Starboard engine
4. Starboard engine

Transmission

The transmission icons indicate which transmission mode your vessel's engine is currently in:

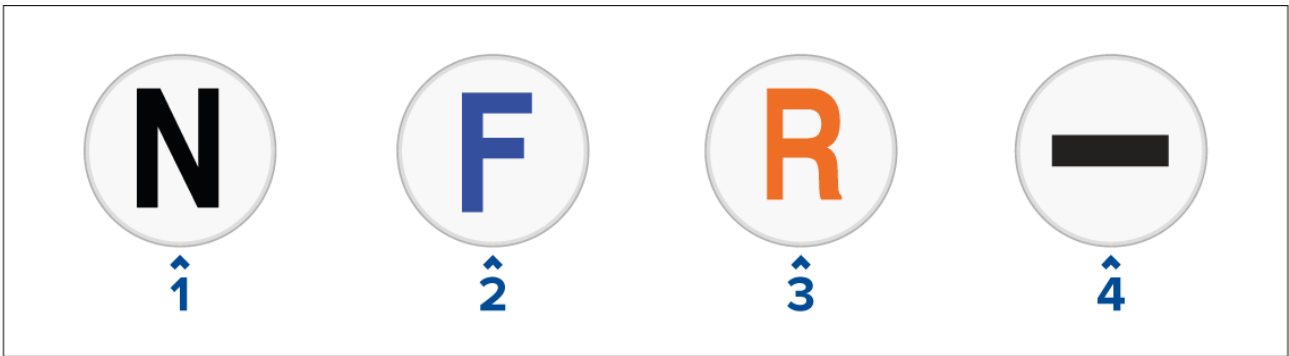

1. Neutral
2. Forward
3. Reverse
4. No transmission data detected

Note:

If no transmission information is detected from the CAN bus after 3 seconds, it will timeout. Ensure that your engine(s) are compatible and have been connected to your MFD network correctly.

Status and warning indicators

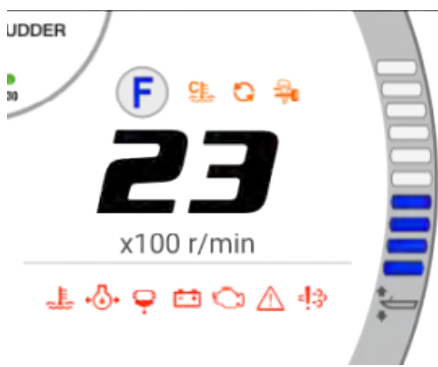

The engine page will display indicators for engine status and warnings.

These status and warning symbols are described below:



1. **Engine warming up status**
2. **Synchronization status**
3. **Immobilizer lock status**

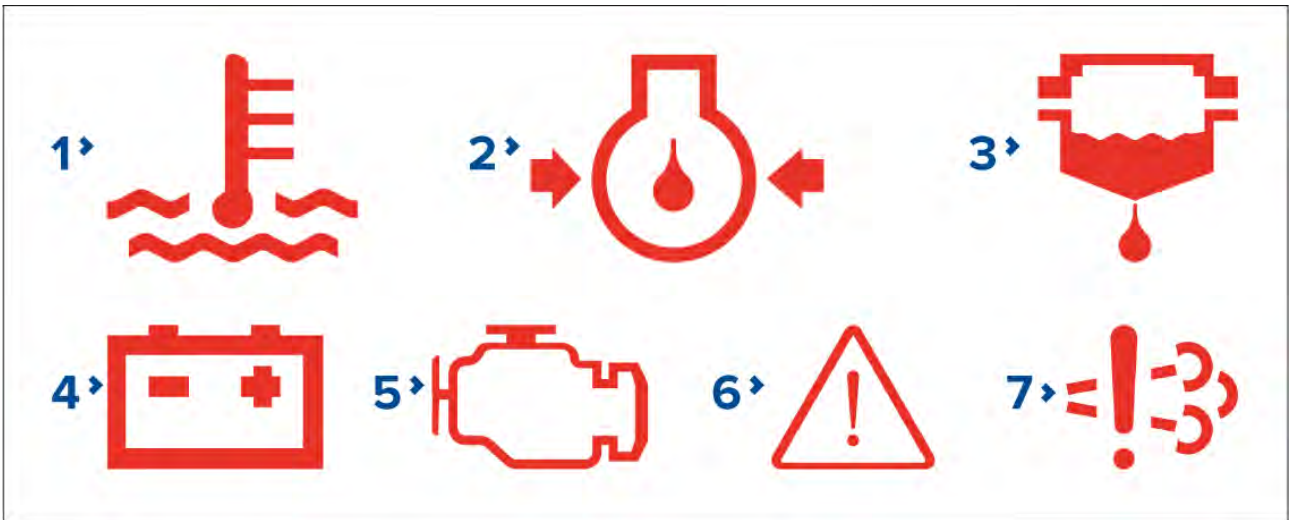

1. **Overheat warning**
2. **Low oil pressure warning**
3. **Water in fuel warning**
4. **Low voltage warning**
5. **Check engine warning**
6. **Steering system warning**
7. **Catalyst warning**

Tanks



The engine page displays the number of tanks aboard your vessel, their type, instance number and fill level.

Note:

- The number of tanks and their type is determined during the installation wizard.
- Tanks require calibration, for more information refer to [Calibrating tanks](#)
- No more than 6 tanks can be displayed on the engine page.
- If there are more than 6 tanks detected on your vessel's network the engine page will display them using the following hierarchy: fuel, fresh water, waste water, gasoline, followed by prioritizing the lowest instance numbers first.

Engine trim



The trim bar displays the trim level of your engine(s), a higher blue bar equates to a higher trim percent. The trim bar will begin to flash if you attempt to set the engine trim beyond 100%.

Troll mode



If your engine supports Troll mode it can be enabled from the engine page. Troll mode is enabled by pressing the Troll mode toggle or by selecting it from the menu.

Note:

- Lower engine RPM and go into idle mode before attempting to activate Troll mode.
- When Troll mode is enabled your RPM gauge will change from x100 r/min to r/min, allowing for more precise control.

13.4 Settings

The settings page can be used to view fault codes, schedule maintenance, and calibrate your engine(s).

Fault codes

The fault codes tab displays all live engine faults detected on the network.

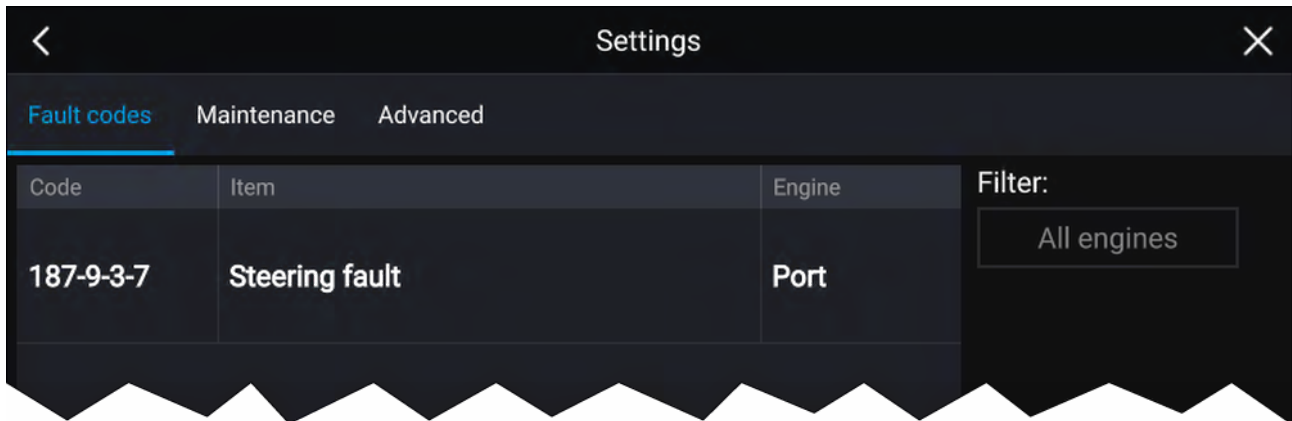

Note:

- The fault codes tab default setting is to display fault codes from all engines.
- You can use the filter option to display fault codes for a specific engine and hide codes for all other engines.

Maintenance

The Maintenance tab displays the amount of time since your Yamaha engine(s) have been serviced.

The amount of hours since last service will automatically accumulate when your Yamaha engine(s) are running. When your engine(s) have been serviced you can long hold the row and select **Reset** from the pop up to return the amount of hours back to 0.

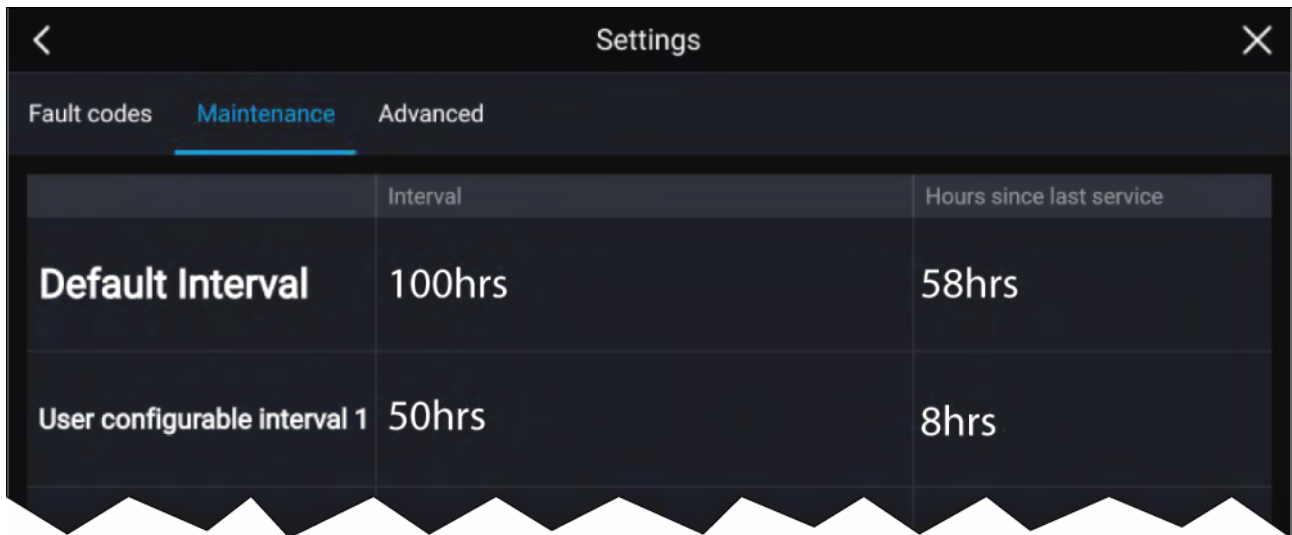

Note:

- A default interval of 100 hours is displayed at the top, this is the recommended maximum amount of time you can use your engine(s) before a service is required.
- Additional user configurable intervals can be customized by long holding each row and choosing the interval length.

Advanced

The Advanced tab is used during the installation and calibration of your Yamaha engine(s). For more information on how to install and calibrate your Yamaha engine(s) refer to Yamaha engine installation manual or Yamaha dealer.

Options:

Gateway reset — System protocol information reset.

Engine instances reset — Engine instances reset. Engine(s) will be reordered based on engine position:

Engine	Port	Central or Central Port	Central Starboard	Starboard
Single Engine	0	-	-	-
Twin Engine	0	-	-	1
Triple Engine	0	1	-	2
Quad Engine	0	1	2	3

All pages reset — All data items on each data page are reset to default.

Fuel flow offset — Set the Fuel flow offset value in accordance with your Fuel flow gauge reading.

Trim Calibration — Calibrate your engine trim by pressing **Set to zero** if any number other than 0 is showing on the Trim Position when engine(s) have stopped.

Chapter 14: Video app

Chapter contents

- [14.1 Video app overview on page 260](#)
- [14.2 Opening the Video app on page 262](#)
- [14.3 Video app settings on page 264](#)
- [14.4 Maritime \(M-Series\) camera compatibility on page 267](#)

14.1 Video app overview

Analog video feeds (Axiom™ Pro only) and IP (Internet Protocol) digital video feeds can be viewed, recorded and played back on the MFD using the Video app. Examples of video feeds include: CCTV cameras and Thermal imaging cameras, DVD player etc. It may also be possible to view analog video feeds from other sources using a suitable third party analog-to-IP video converter.

Up to 4 video feeds can be displayed simultaneously when using a splitscreen app page.

Axiom™ Pro MFDs will transmit a connected analog video feed over RayNet to enable the feed to be viewed on networked MFDs.

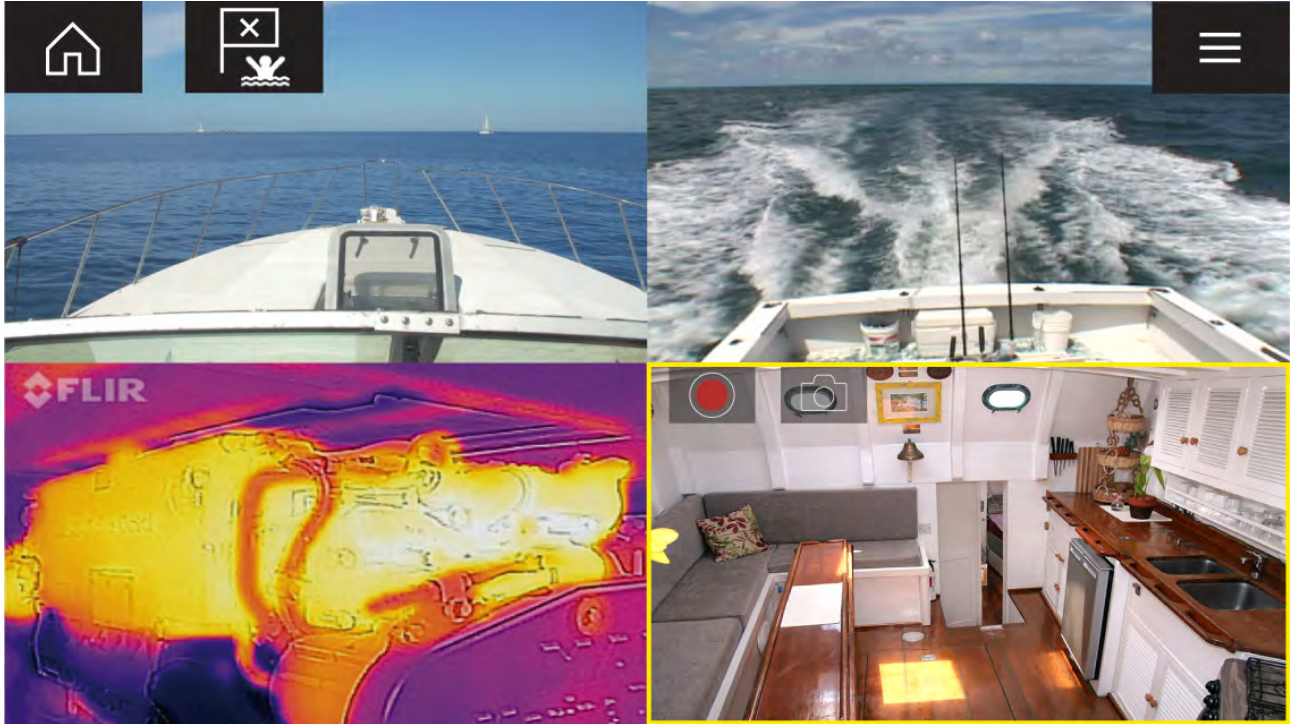

Video app pages

Each Video app instance is unique, this means that once you have selected a feed to display in a Video app page then your feed selection is saved and the same feed will be displayed whenever that app page icon is opened from the Homescreen. If you open the same Video app page from a networked MFD, the same feed will be displayed on each MFD.

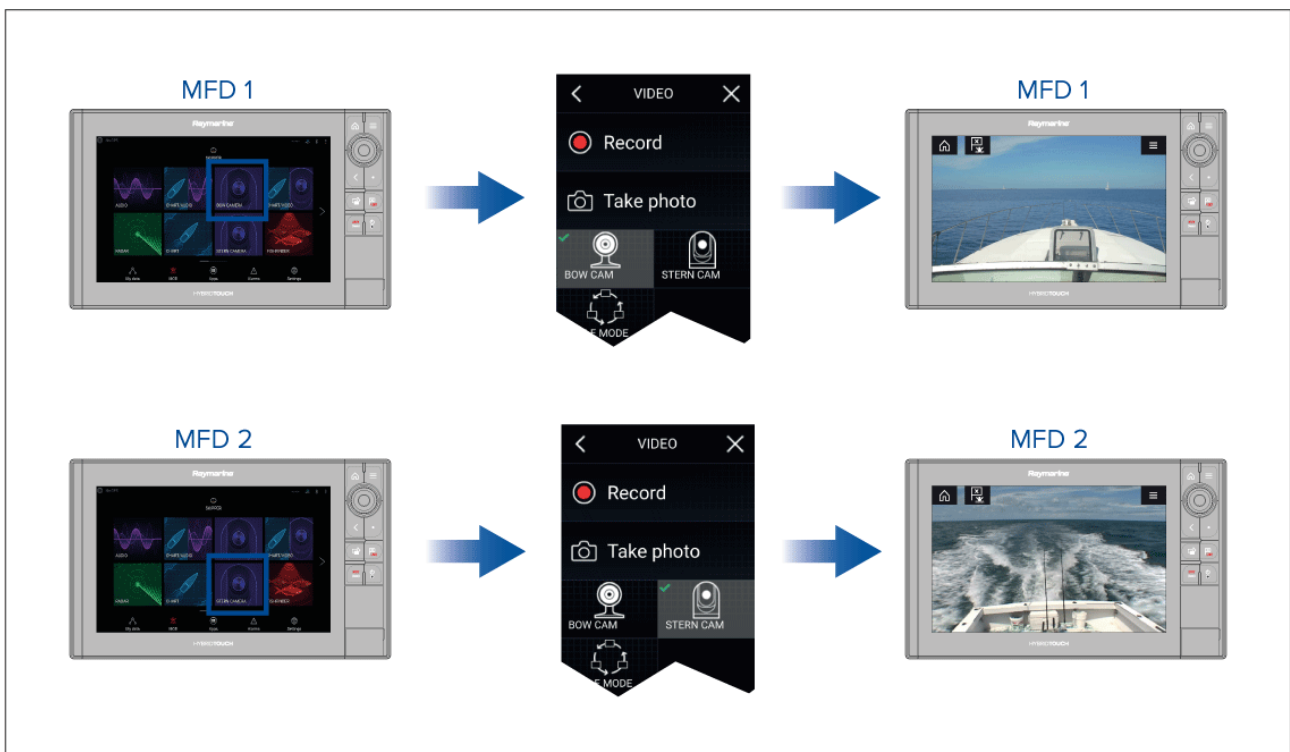

You can create additional Video app pages and assign a different feed to each. This will allow you to view multiple feeds on multiple networked MFDs simultaneously.

For example, if you want to display a different video feed on different networked MFDs, you must first create additional Video app pages.

Note:

When you have multiple Video app page icons on your Homescreen, you may wish to rename each icon to help you easily identify the feeds(s) assigned to each app page. For information on how to rename Homescreen icons, refer to:

[5.4 Creating / Customizing an App page](#)

Renaming video feeds







In multi camera installations you can rename your feed from within the Video app.

From the Video app menu:

1. Select the icon for the camera you want to rename so that its feed is displayed.
2. Goto the Video app's **Settings** menu: **Menu > Settings**.
3. Select the **Camera setup** tab.
4. Select the Camera name field.
5. Use the onscreen keyboard to rename your feed and then select **Save**.

Repeat the above steps for each video feed you want to rename. You can also associate a different icon to your video feed by selecting on the **Icon** field.

Video app controls

Icon	Description	Function
	Home icon	Takes you to the Homescreen
	Waypoint / MOB	Place waypoint / activate Man overboard (MOB) alarm
	Pilot icon	Opens and closes the Pilot Sidebar
	Menu icon	Opens the app menu
	Record	Start recording (Replaced by Stop icon whilst recording.)
	Stop	Stop recording (Replaced Record icon when not recording.)
	Take photo	Take a photo of what is currently displayed in the active feed.

Pan, Tilt, Zoom (PTZ) camera controls

Extra controls are available for cameras that can pan, tilt or zoom.

Swiping your finger across the screen to pan or tilt the camera.

Use Pinch-to-Zoom to zoom in and out.

When not in use place the camera in the Parked position by selecting **Park camera** from the menu:
Menu > Park camera

Select **Home** from the menu: **Menu > Home** to move the camera to its Home position.

14.2 Opening the Video app

The Video app is opened by selecting an app page icon from the Homescreen which includes the Video app.

Pre-requisites:

1. Ensure your video feed is compatible by checking the latest details available on the Raymarine website against your device's specification. If in doubt please contact an authorized Raymarine dealer for advice.
2. Ensure you have installed your video device in accordance with the documentation that was supplied with your device.

The Video app will open in 1 of 3 states:

Note: If the Video app is opened soon after powering on your system, you may have to wait for the device(s) to finish booting before the video feed is displayed.

Video feed displayed

If your device is powered up and operational then the Device's video feed is displayed.



Camera not yet available

The '**Camera not yet available**' message is displayed if:

- a Video app page is opened before the camera has finished booting up.
- connection to the camera is lost.



CAM200 not yet available. Camera may be booting, or may have connection issues.

If the **'Camera not yet available'** message is displayed for more than 2 minutes, then your MFD cannot connect to your camera. Ensure network and power connections to your camera and MFD are correct and free from damage and then power cycle your system. If the camera feed is still not displayed, refer to your equipment's installation documentation for further troubleshooting information.

No camera detected

The **'No camera detected'** message is displayed if:

- a Video app page is opened for the first time and no compatible camera is connected.
- a Video app page is opened for the first time before the camera has finished booting up.



No camera detected

If the **'No camera detected'** message is displayed for more than 2 minutes, then your MFD cannot connect to your camera. Ensure network and power connections to your camera and MFD are correct and free from damage and then power cycle your system. If the camera feed is still not displayed, refer to your equipment's installation documentation for further troubleshooting information.

Selecting a video feed

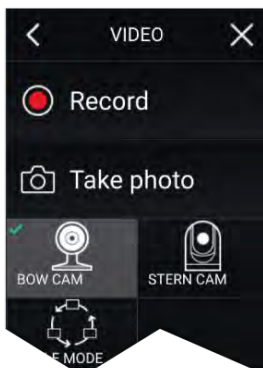

You can change the feed that is displayed in the Video app. From the Video app main menu, select the icon for the camera that you want to display.

Dual streaming

M-Series cameras with dual payloads (visible and thermal camera lens) can stream a visible feed and thermal feed simultaneously.



Note:

Dual streaming requires:

- A dual payload M-Series camera: M300, M400 and M500.
- Lighthouse software version 3.11 or later.

Single MFD

Activate dual video streaming on a single MFD.

1. From the **Homescreen**, create a custom combo app that comprises of at least 2 **Video apps**. For more information on creating and customizing LightHouse apps, refer to: [p.55 – Creating / Customizing an App page](#)
2. Open the combo app and select one of the Video app sections.
3. Select the dual payload camera and select the stream you want to display (visible or thermal):

Combo app > Menu > Settings > Image Tab > Active feed > Visible / Thermal

4. Repeat steps 2 and 3 for the other section and video stream.

Dual MFDs

Activate dual video streaming on at least 2 MFDs connected on the same network.

Note:

Make sure your MFDs are both correctly connected on the same network as the dual payload camera.

1. Open the **Video app** on one of the MFDs.
2. Select the dual payload camera and select the stream you want to display (visible or thermal):

Video app > Menu > Settings > Image Tab > Active feed > Visible / Thermal

3. Repeat steps 1 and 2 for the other MFD and video stream.

14.3 Video app settings

The Settings menu provides access to the Video app's features and functions. The options available in the Settings menu are dependent on your system configuration and connected devices.

Image tab

Settings	Description	Options
Active feed	On cameras with more than 1 payload you can select which feed to display in the Video app.	<ul style="list-style-type: none"> • Thermal • Visible
Blending Mode	<p>On cameras with more than 1 payload you can blend the two feeds together, displaying an overlap of daylight stream on top of thermal image, providing enhanced detail.</p> <ul style="list-style-type: none"> • CTV - Coloured daylight image blended with the thermal feed. • MSX - Black and white daylight image detects and sharpens the edges of objects shown on the thermal feed. 	<ul style="list-style-type: none"> • Off • CTV • MSX
Blending Level	Set the percentage of the blend between both camera feeds for CTV or MSX blending.	<ul style="list-style-type: none"> • 0% to 100%
Light	For cameras that include a light this setting switches the camera's light on and off as well as flashing mode and SOS mode.	<ul style="list-style-type: none"> • On • Off • Flash • SOS

Settings	Description	Options
Palette	Various color palettes are available to suit different conditions or your personal preference.	<ul style="list-style-type: none"> • WhiteHot • BlackHot • RedHot • RedHot Inverse • Fusion • Firelce • Firelce Inverse
Scene	Scene presets that have been optimized for different running conditions.	<ul style="list-style-type: none"> • Day • Night • Docking • High contrast
Auto focus	The camera will focus the image.	<ul style="list-style-type: none"> • Activate
Low light mode	Visible cameras supporting low light mode can set this during low light conditions.	<ul style="list-style-type: none"> • On • Off • Auto
Wide Dynamic Range	Improves the viewable range of darkness to lightness of the image.	<ul style="list-style-type: none"> • Disable • Enable
Contrast Enhancement	Adjusts the brightness and contrast of the image to make dark and bright sections more distinguishable.	<ul style="list-style-type: none"> • Disable • Enable
Electronic stabilization	Stabilizes the image to reduce blurring caused by camera shake.	<ul style="list-style-type: none"> • Disable • Enable
Digital Zoom	Zooms the camera feed to maximum.	<ul style="list-style-type: none"> • Disable • Enable
Roll correction <i>(Requires AR200)</i>	Accounts for boat tilting and will adjust video feed accordingly. Video feed horizon will be parallel with the actual horizon.	<ul style="list-style-type: none"> • Disable • Enable

Camera setup tab

Settings	Description	Options
Heater	Enables and disables the camera's built-in heater used to de-mist the camera lens.	<ul style="list-style-type: none"> • Disable • Enable
Zoom Lock	Synchronise zoom level between visible and thermal camera feeds.	<ul style="list-style-type: none"> • Disable • Enable
Mirrored view	Flips the camera image to provide a mirror image, suitable for rear view installations.	<ul style="list-style-type: none"> • Disable • Enable
Camera name	Change your camera name.	<ul style="list-style-type: none"> • Displays the onscreen keyboard.
Icon	Select the icon to be used for the camera.	<ul style="list-style-type: none"> • List of icons.
Flip image vertical	Flips the camera image upside down, suitable for Ball-down installations.	<ul style="list-style-type: none"> • Disable • Enable
UI language	Select the language of the user interface.	<ul style="list-style-type: none"> • List of languages.

Settings	Description	Options
On-screen icons	Sets the level for the camera's built-in onscreen icons	<ul style="list-style-type: none"> • None • Minimal • All
Save default settings	Save the current camera settings as the default.	<ul style="list-style-type: none"> • Save
Restore default settings	Restore the camera settings to default.	<ul style="list-style-type: none"> • Run default restore
Self-tests and calibration	Offers a series of tests and calibration options for your camera.	<ul style="list-style-type: none"> • Pan/tilt test • Reset IR lens • Flat Field Correction • Set elevation reference • Set forward position
Restore factory settings	Restore camera settings to factory default.	<ul style="list-style-type: none"> • Run factory restore

Photo & Video recording tab

Settings	Description	Options
Save files to:	Determines the save location for photos and video recordings. <div style="border: 1px solid black; padding: 5px; margin-top: 10px;"> <p>Note: External SD 1 and USB Media are available when using the RCR-SDUSB Accessory.</p> </div>	<ul style="list-style-type: none"> • SD 1 • External SD 1 USB Media

ClearCruise tab (Augmented Reality) *(Requires AR200)*

Settings	Description	Options
Augmented Reality	Enables / disables Augmented Reality and Augmented reality settings.	<ul style="list-style-type: none"> • Disable • Enable
AIS labels	Display other vessels as flags (requires AIS).	<ul style="list-style-type: none"> • Disable • Enable
Hide static targets	Hide AIS targets travelling under 2 knots (requires AIS).	<ul style="list-style-type: none"> • Disable • Enable
Waypoints	Display Waypoints as flags.	<ul style="list-style-type: none"> • Disable • Enable
Chart objects	Display Chart objects as flags (requires compatible charts).	<ul style="list-style-type: none"> • Disable • Enable
Cartography source	Select the cartography ClearCruise displays data from (requires compatible charts).	<ul style="list-style-type: none"> • Cartography source options
Compass	Display the Compass bar.	<ul style="list-style-type: none"> • Disable • Enable
Range limit	Set the maximum range flags will automatically be displayed from.	<ul style="list-style-type: none"> • 1/8nm to 13nm

ClearCruise tab (Object Detection)

Settings	Description	Options
Highlight detected objects	Uses proprietary ClearCruise™ technology to highlight and track objects detected in the water.	<ul style="list-style-type: none"> • Disable • Enable
Beep on detection	When enabled the MFD will beep when an object is detected.	<ul style="list-style-type: none"> • Disable • Enable
Display estimated range	When enabled the MFD will display an estimated range for highlighted objects (objects must be closer than 300ft)	<ul style="list-style-type: none"> • Disable • Enable

Camera motion tab

Settings	Description	Options
Camera height above the waterline	To ensure correct alignment of the camera for tracking purposes the height the camera has been installed at, above the waterline, must be set.	<ul style="list-style-type: none"> • 0ft to 99ft
Set forward position	Adjust the Forward position of your camera	Displays the forward alignment picture
Man overboard	Enables and disables automatic tracking of a MOB alarm. The most recent target is tracked.	<ul style="list-style-type: none"> • Disable • Enable
Dangerous AIS targets	Enables and disables automatic tracking of Dangerous AIS targets. The most recent target is tracked.	<ul style="list-style-type: none"> • Disable • Enable
Dangerous MARPA targets	Enables and disables automatic tracking of Dangerous Radar targets. The most recent target is tracked.	<ul style="list-style-type: none"> • Disable • Enable
Enable scan	Enables and disables Surveillance mode. Surveillance mode pans the camera left to right continuously to the specified speed	<ul style="list-style-type: none"> • Disable • Enable
Scan width	Determines how far the camera pans from left to right when in Surveillance mode.	<ul style="list-style-type: none"> • Narrow • Medium • Wide
Scan speed	Determines the speed at which the camera pans from left to right when in Surveillance mode.	<ul style="list-style-type: none"> • Slow • Medium • Fast

Page settings

Settings	Description	Options
Edit data overlays	Add data overlays to video feed.	<ul style="list-style-type: none"> • List of data overlays

14.4 Maritime (M-Series) camera compatibility

Support for the various video features and settings, as per each M-Series camera variant.

For an explanation of the settings listed in the following table, refer to: [p.264 – Video app settings](#)

Not applicable to product	—
Applicable to product	

Applicable to product (M200 only)	(M200 only)			
Applicable to dual payload M300 variants only	***			
IMAGE TAB				
Setting	M100/M200	M300***	M400	M500
Active feed <ul style="list-style-type: none"> • Thermal • Visible 	—			
Blending mode <ul style="list-style-type: none"> • Off • CTV • MSX 	—		—	—
Blending level <ul style="list-style-type: none"> • 0% to 100% 			—	—
Light <ul style="list-style-type: none"> • Off • On • Flash • SOS 	—	—		
Palette (Thermal feed) <ul style="list-style-type: none"> • WhiteHot • BlackHot • RedHot • RedHot Inverse • Fusion • Fusion Inverse • Firelce • Firelce Inverse 				
Scene (Thermal feed) <ul style="list-style-type: none"> • Day • Night • Docking • High Contrast 				
Auto focus (Visible feed) <ul style="list-style-type: none"> • Activate 	—	—		
Low light mode (Visible feed) <ul style="list-style-type: none"> • Off • On • Auto 	—			
Wide dynamic range (Visible feed) <ul style="list-style-type: none"> • Disable • Enable 	—			

IMAGE TAB				
Contrast enhancement <i>(Visible feed)</i> <ul style="list-style-type: none"> • Disable • Enable 	—			
Electronic stabilisation <i>(Visible feed)</i> <ul style="list-style-type: none"> • Disable • Enable 	—	—	—	
Digital Zoom <ul style="list-style-type: none"> • Disable • Enable 				
Roll correction <i>(Requires AR200)</i> <ul style="list-style-type: none"> • Disable • Enable 			—	—

CAMERA SETUP TAB				
Setting	M100/M200	M300***	M400	M500
Heater <ul style="list-style-type: none"> • Disable • Enable 				
Zoom lock <ul style="list-style-type: none"> • Disable • Enable 	—			
Mirrored view <ul style="list-style-type: none"> • Disable • Enable 				
Camera name <ul style="list-style-type: none"> • Onscreen keyboard 				
Icon <ul style="list-style-type: none"> • List of camera icons 				
Flip image vertical <ul style="list-style-type: none"> • Disable • Enable 				
UI language <ul style="list-style-type: none"> • List of available languages 	—			
On-screen icons <ul style="list-style-type: none"> • None • Minimal • All 	—			
Save default settings <ul style="list-style-type: none"> • Save 	—			
Restore default settings <ul style="list-style-type: none"> • Run default restore 	—			

CAMERA SETUP TAB				
Self-tests and calibration				
Pan/tilt test		—		
Set elevation reference				
Set forward position				
Spotlight test	—	—		
Self-tests and calibration (<i>Thermal feed</i>)				
IR test pattern	—	—		
Reset IR lens		—		
Flat field correction				
Restore factory settings				
• Run factory restore				

PHOTO & VIDEO RECORDING				
Setting	M100/M200	M300***	M400	M500
Save files to				
• List of connected SD cards				

CLEARCRUISE™				
Setting	M100/M200	M300***	M400	M500
ClearCruise™ Augmented Reality (<i>Requires AR200</i>)			—	—
Augmented Reality			—	—
• Disable				
• Enable				
AIS targets			—	—
• Disable				
• Enable				
Hide static targets			—	—
• Disable				
• Enable				
Waypoints			—	—
• Disable				
• Enable				
Chart objects			—	—
• Disable				
• Enable				
Cartography source			—	—
• Disable				
• Enable				
Compass			—	—
• Disable				
• Enable				

CLEARCRUISE™				
Range limit <ul style="list-style-type: none"> • Disable • Enable 			—	—
ClearCruise™ Object Detection		—	—	—
Highlight detected objects <ul style="list-style-type: none"> • Disable • Enable 		—	—	—
Beep on detection <ul style="list-style-type: none"> • Disable • Enable 		—	—	—
Display estimated range <ul style="list-style-type: none"> • Disable • Enable 		—	—	—

CAMERA MOTION				
Setting	M100/M200	M300***	M400	M500
Camera height above waterline <ul style="list-style-type: none"> • Adjust value 				
Forward position <ul style="list-style-type: none"> • Adjust position and Save 	<i>(M200 only)</i>			
Man overboard <ul style="list-style-type: none"> • Disable • Enable 	<i>(M200 only)</i>			
Dangerous AIS target <ul style="list-style-type: none"> • Disable • Enable 	<i>(M200 only)</i>			
Dangerous MARPA target <ul style="list-style-type: none"> • Disable • Enable 	<i>(M200 only)</i>			
Vertical stabilization <ul style="list-style-type: none"> • Disable • Enable 	<i>(M200 only)</i>			
Horizontal stabilization <ul style="list-style-type: none"> • Disable • Enable 	<i>(M200 only)</i>			
Enable scan <ul style="list-style-type: none"> • Disable • Enable 	<i>(M200 only)</i>			

CAMERA MOTION				
Scan width • Disable • Enable	<i>(M200 only)</i>			
Scan speed • Disable • Enable	<i>(M200 only)</i>			
PAGE SETTINGS				
Setting	M100/M200	M300***	M400	M500
Edit data overlays • List of data overlays				

Chapter 15: ClearCruise (Object Detection and Augmented Reality)

Chapter contents

- [15.1 ClearCruise™ features on page 274](#)
- [15.2 Camera setup on page 275](#)
- [15.3 AR200 setup for Augmented Reality on page 279](#)
- [15.4 ClearCruise™ object detection overview on page 279](#)
- [15.5 Augmented Reality \(AR\) overview on page 281](#)
- [15.6 Augmented Reality flags on page 282](#)
- [15.7 ClearCruise settings \(Augmented Reality\) on page 286](#)
- [15.8 Roll correction on page 288](#)
- [15.9 AR200 Calibration \(Linearization\) on page 290](#)

15.1 ClearCruise™ features

ClearCruise™ features are designed for enhancing situational awareness and aiding navigation.

ClearCruise™ technology provides 2 separate features:

- Object Detection
- Augmented Reality (AR)

Object Detection

Object Detection is a feature available for M100 and M200 Series thermal cameras. Intelligent thermal analytics technology provides audible and visual alerts when “non-water” objects are identified in the scene. Vessels, obstacles, and navigation markers can all be automatically identified by the camera without the need for Chart or Radar data.

Required components for Object Detection

- MFD: Axiom / Axiom Pro / Axiom XL, or eS Series / gS Series running LightHouse 3.
- Thermal Camera (M100 or M200 Series)
- LightHouse™ software (v3.0 or later)

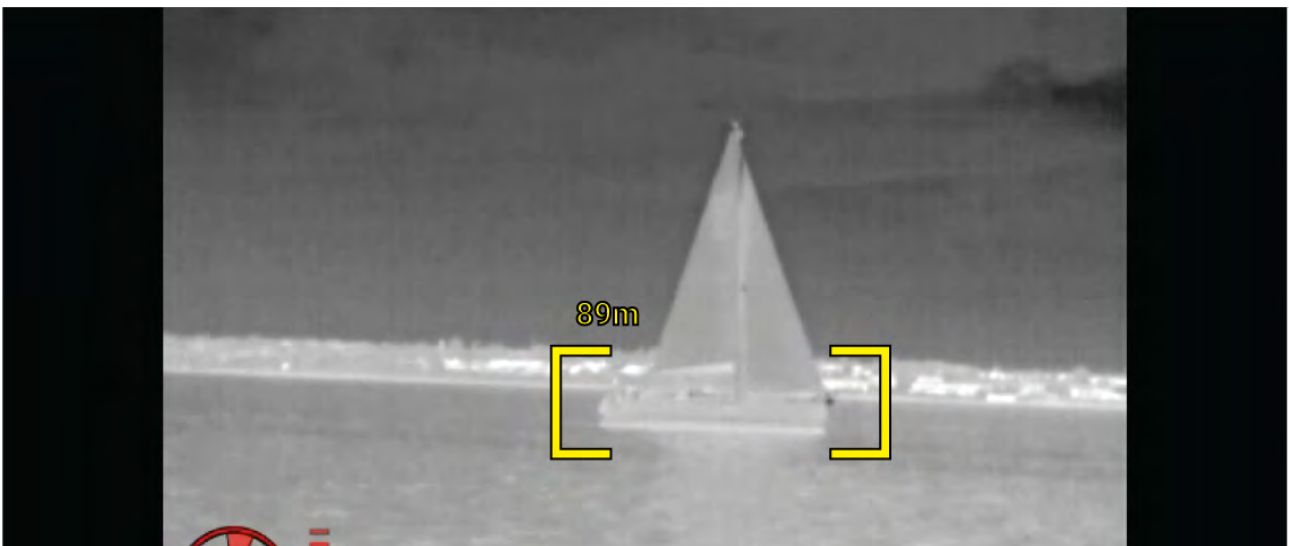

Augmented Reality

The **Augmented Reality** feature places layers of digital information directly over the top of the Video app's video feed. Data from the Chart app is used to generate informative text and images (flags) on the Video app. When calibrated correctly, ClearCruise™ Augmented Reality accurately overlays automatically-updating flags on the Video app so they overlap real-life objects.

Required components for Augmented Reality (IP cameras)

- MFD (Axiom, Axiom Pro or Axiom XL)
- AR200 Augmented Reality Sensor
- IP camera (CAM210IP or CAM220IP)
- LightHouse™ software (v3.7 or later)

Required components for Augmented Reality (M-Series cameras)

- MFD (Axiom, Axiom Pro or Axiom XL)
- AR200 Augmented Reality Sensor
- M-Series camera (M100, M200 and M300 Series)
- M100 / M200-Series cameras require LightHouse™ software version 3.9 or later.
- M300-Series cameras require LightHouse™ software version 3.10.71 or later.

Important:

Cameras utilizing ClearCruise™ Augmented Reality are subject to an unstable image on rough waters.



Note: ClearCruise's performance is dependent on environmental conditions and is not a replacement for maintaining a visual watch.

15.2 Camera setup

Before using the Augmented Reality features, it's important to correctly install and setup your compatible camera.

Refer to your camera's installation manual to determine the correct physical installation and connections for using the camera as part of an Augmented Reality system.

A number of additional camera-related settings and calibrations must be completed in the Video app before Augmented Reality features can be used:

- Camera height above the waterline.
- Camera direction.
- Camera horizontal field of view [not required for cameras which auto assign their field of view].
- Horizon calibration.

Note:

- The camera's height above the waterline and camera's view direction need to be physically measured for accurate camera installation.
- The camera's horizontal field of view can be found in your camera's installation manual specification.

Fixed camera calibration

Fixed mount cameras require calibration for Augmented Reality to function correctly.

1. For first time setup, either:
 - i. Select the **Enter Details** prompt in the Video app.
 - ii. Select the **ClearCruise** tab in the Video app's Settings, **Video app > Settings > ClearCruise**. There will be a prompt to **Enter Details** using the **Camera Installation** page.
2. Go directly to the **Camera Installation** page in the Video app (**Settings > Camera Setup > Camera Installation**).

3. The **Camera Installation** page will offer a series of camera installation options which all need to be completed correctly.

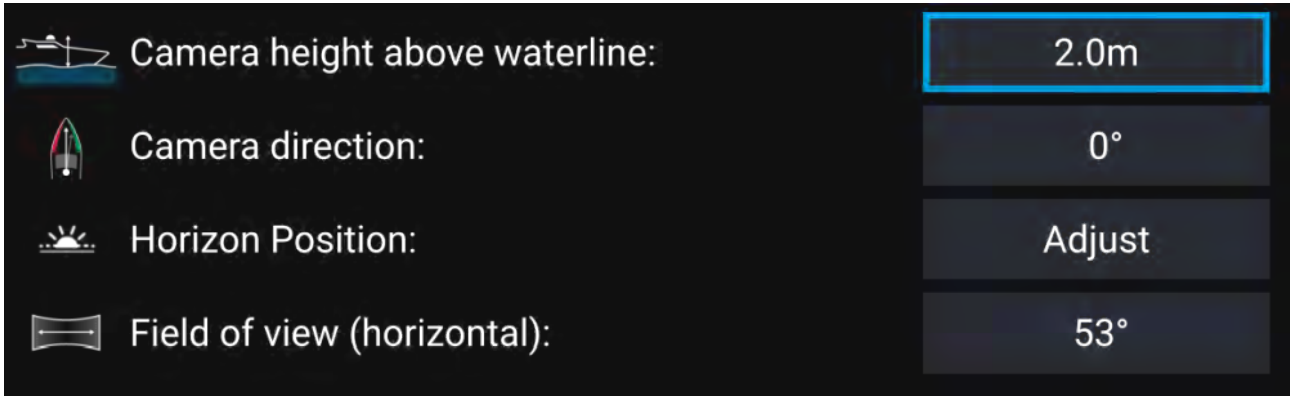

Note:

Incorrect physical camera installation and incorrect settings provided in the camera setup page could result in an inaccurate Augmented Reality overlay.

- To adjust the values of **Camera height above waterline**, **Camera direction** and **Field of view**, select the value boxes of each option and adjust using the arrows.

Menu item	Options
Camera height above waterline	<ul style="list-style-type: none"> • 0m to 50m • 0ft to 165ft
Camera direction	<ul style="list-style-type: none"> • 0° (Forward) (default) • 0° to 180°p (Port) • 0° to 180°s (Starboard)
Field of view	<ul style="list-style-type: none"> • 30° to 120° • [CAM210IP – 53°] • [CAM220IP – 93°]

- To Calibrate horizon, use the **up**, **down**, **rotate left** and **rotate right** arrow keys until the red line is placed on the horizon. When the line is in position, select **Save**.

Important:

Calibrating the horizon correctly is essential for accurate Augmented Reality overlay. Calibrating on calm water and in clear sight of the horizon is recommended.

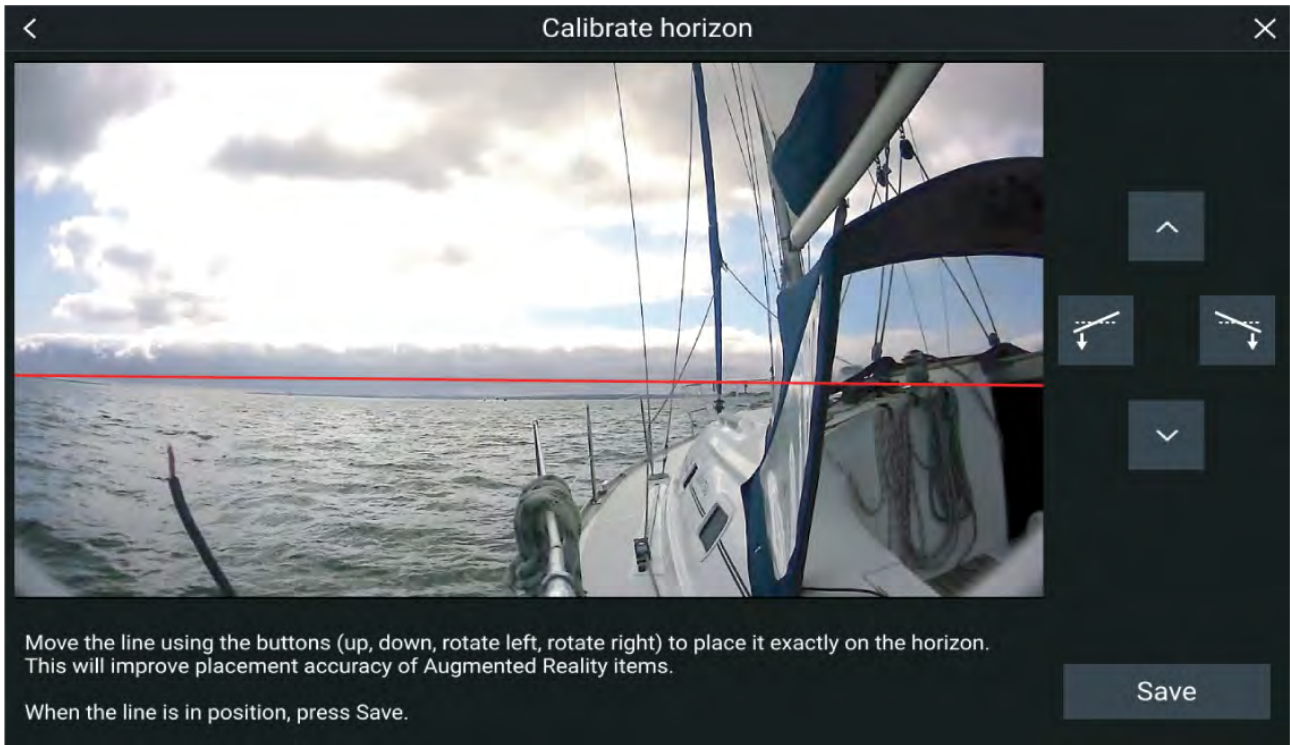

Pan and Tilt camera calibration

Pan and Tilt cameras require calibration for Augmented Reality to function correctly.

1. For first time setup, either:
 - i. Select the **Enter Details** prompt in the Video app.
 - ii. Select the **ClearCruise** tab in the Video app's Settings, **Video app > Settings > ClearCruise**. There will be a prompt to **Enter Details** using the **Camera Installation** page.
2. Go directly to the **Camera Installation** page in the Video app (**Settings > Camera Setup > Camera Installation**).
3. The **Camera Installation** page will offer a series of camera installation options which all need to be completed correctly.

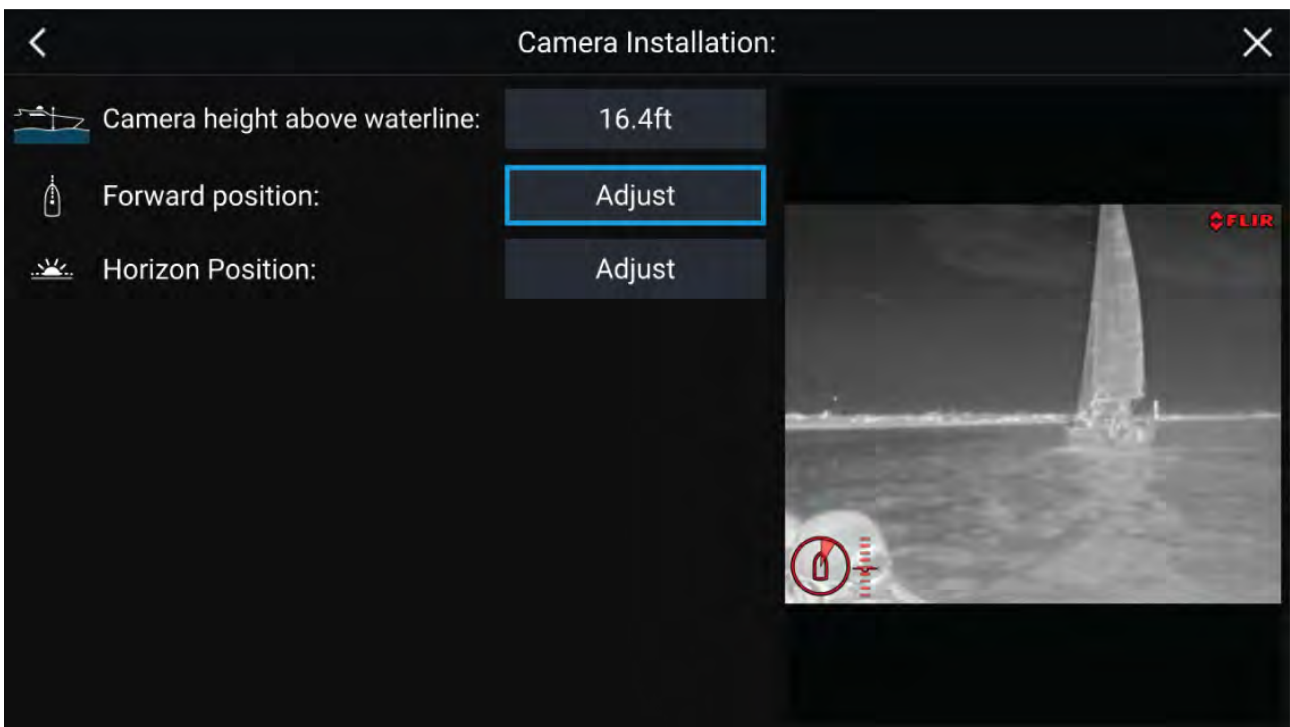

Note:

Incorrect physical camera installation and incorrect settings provided in the camera setup page could result in an inaccurate Augmented Reality overlay.

- To adjust the values of **Camera height above waterline** select the value box and adjust using the arrows.

Menu item	Options
Camera height above waterline	<ul style="list-style-type: none">• 0m to 50m• 0ft to 165ft

- To Calibrate the camera's **Forward Position** adjust the camera direction so the vertical black line is positioned directly forward, parallel to your vessels forward position.

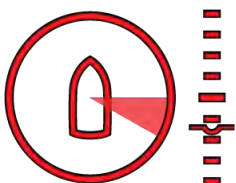
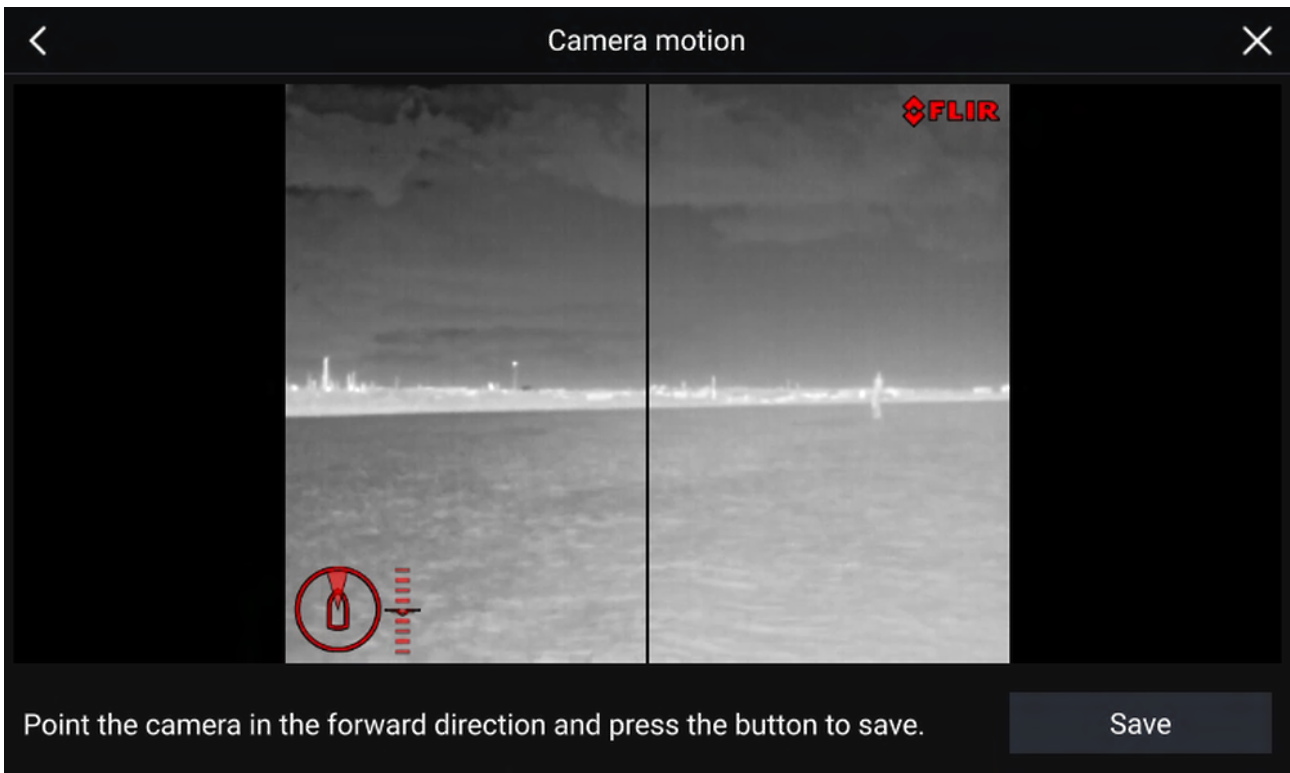

Important:

- Calibrating the cameras forward position is essential for accurate Augmented Reality overlay when the camera pans and tilts. Calibrating on calm water and with a clear view of the front of your vessel is recommended.
- Certain cameras display a camera direction indicator which can help identify when the camera is facing directly forward.

- To Calibrate the camera's **Horizon position** use the arrow keys to align the horizontal red line so it is level with the horizon.
- Pan and tilt the camera 360° during calibration to ensure the horizon line has been positioned correctly.

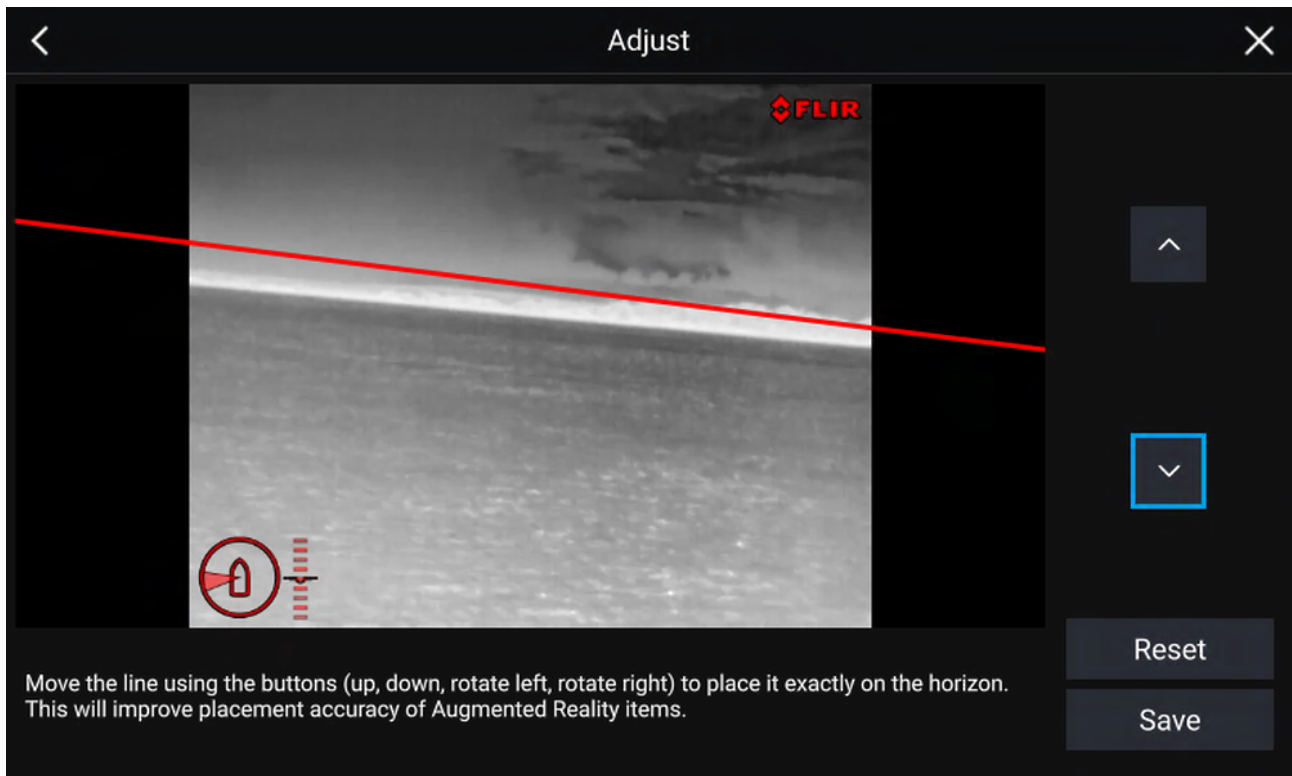

Important:
 Calibrating the horizon correctly is essential for accurate Augmented Reality overlay. Calibrating on calm water and in clear sight of the horizon is recommended.

15.3 AR200 setup for Augmented Reality

Before using the Augmented Reality features, it's important to correctly install and setup the AR200 Augmented Reality sensor.

Refer to the AR200 Installation manual (87372) to determine the correct physical installation and connections for using the AR200 as part of an Augmented Reality system.

15.4 ClearCruise™ object detection overview

Object detection provides audible and visual alerts when “non-water” objects are identified by connected M100/M200 Series cameras.

Objects that visually differ from the water will be identified by the camera as a “non-water” object.

The following features are available with Object detection:

- **Highlight detected objects** — Enables/disables object highlighting, which automatically identifies and highlights “non-water” objects.
- **Beep on detection** — Enables/disables a beep when an object is detected (**Highlight detected objects** must be enabled)
- **Display estimated range** — Enables/disables display of an object’s estimated range from your vessel (**Highlight detected objects** must be enabled, and object must be closer than approximately 100 m (~300 ft)).

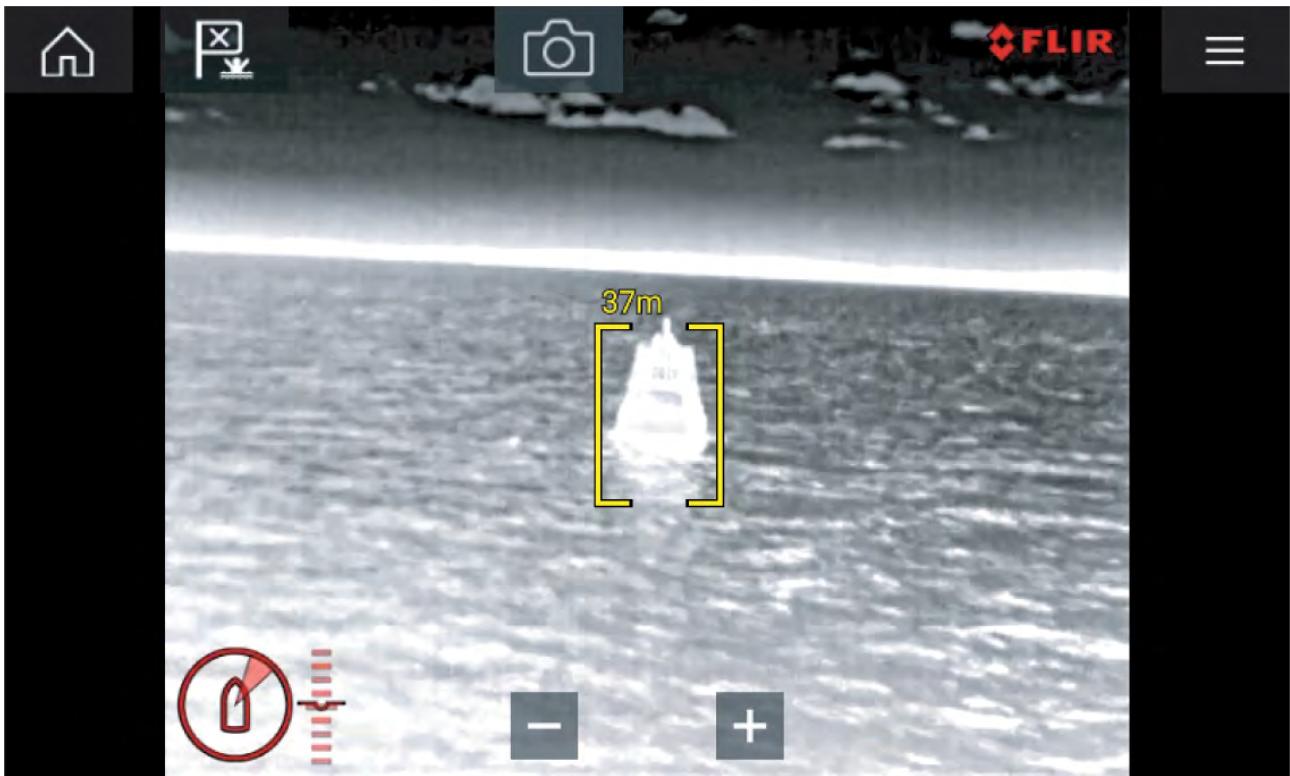

- Object detection can be particularly useful at night or visually limiting environments such as storms or fog.
- In the event of an emergency, such as man overboard, Object detection could be a useful aid that helps to identify and predict the distance from the MOB.

Note: ClearCruise's performance is dependent on conditions and is not a replacement for maintaining a visual watch.

ClearCruise settings (Object Detection)

Object Detection features and settings can be enabled and disabled in the **ClearCruise** tab in the Video app.

Video app > Settings > ClearCruise

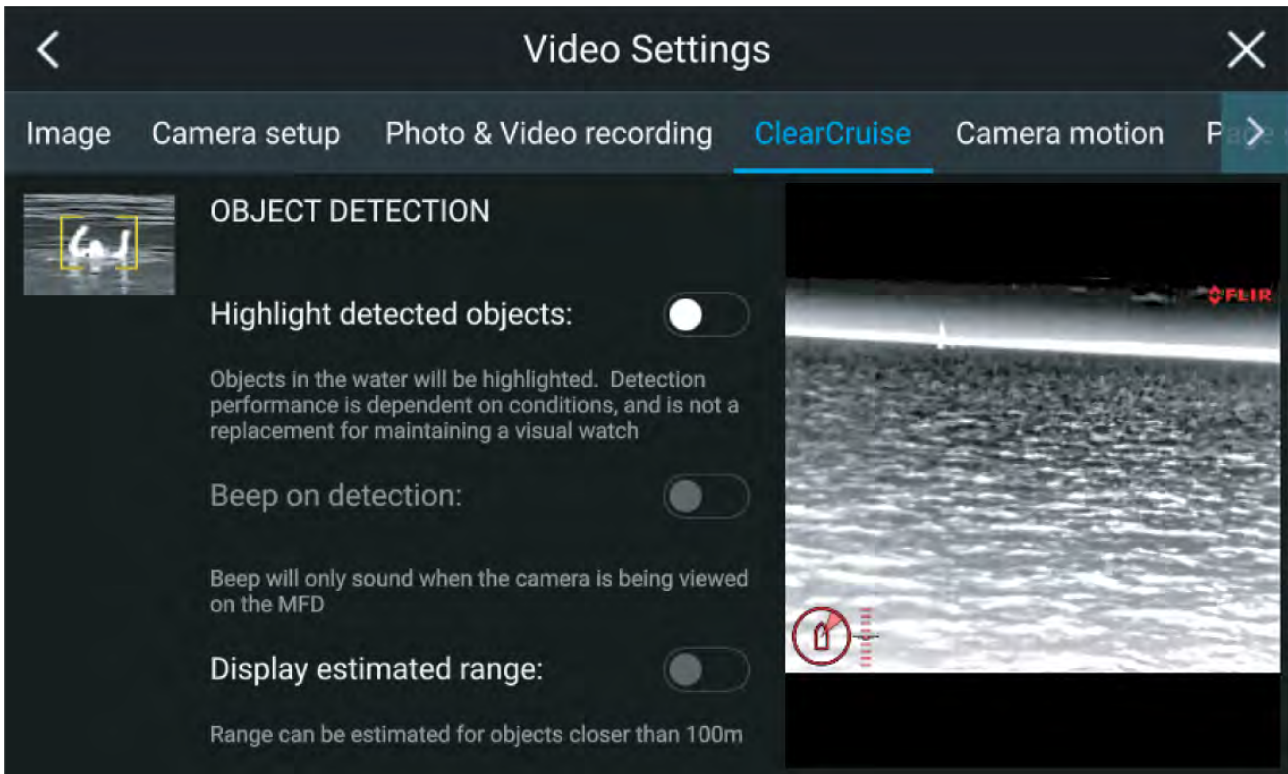

Setting	Description
Highlight detected objects	Enables/disables object highlighting.
Beep on detection	Enables/disables an audible beep when an object is detected (Highlight detected objects must be enabled).
Display estimated range	Enables/disables display of an object's estimated range from your vessel (Highlight detected objects must be enabled, and the object must be closer than approximately 100 m (~300 ft).

Important: ClearCruise Object Detection is only compatible with cameras that are positioned upright. ClearCruise Object Detection will not function with cameras that are upside down and have vertical flip enabled.

15.5 Augmented Reality (AR) overview

ClearCruise™ Augmented Reality uses data from the Chart app and displays this data in realtime as an overlay in the Video app.

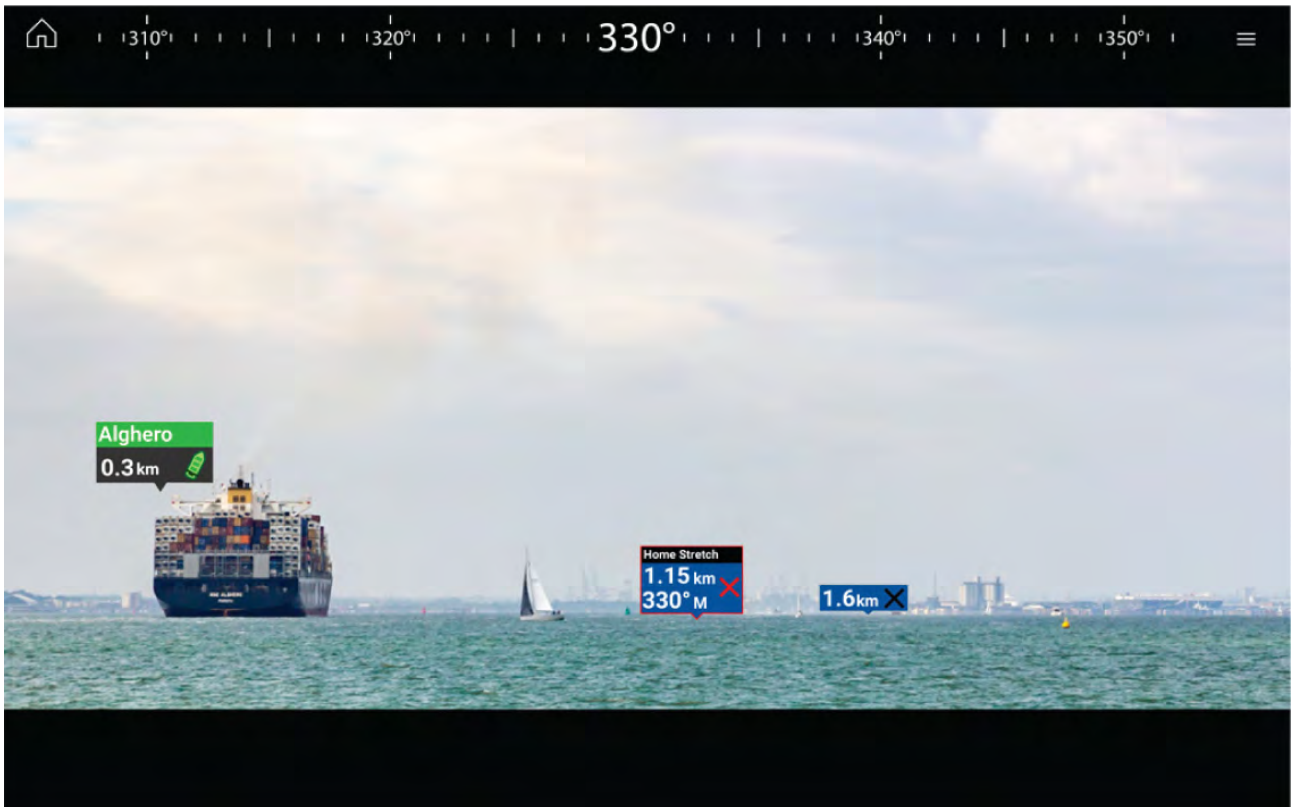

The **Augmented Reality** feature places layers of digital information directly over the top of the Video app's video feed. Data from the Chart app is used to generate informative text and images (flags) on the Video app. When calibrated correctly, ClearCruise™ Augmented Reality accurately overlays automatically-updating flags on the Video app so they overlap real-life objects.

The Augmented Reality feature requires an Axiom, Axiom Pro or Axiom XL MFD, an AR200 sensor and a compatible camera.

For more information, refer to: [p.274 — ClearCruise™ features](#)

Note:

- The Augmented Reality feature requires correct camera calibration for accurate image overlay.
- The Augmented Reality feature serves as an aid to navigation and situational awareness only, and should not be solely relied on for precise navigation. Always maintain a visual watch.

Important: Rear-facing cameras with a flipped or mirrored image may not place Augmented Reality content as accurately as a forward-facing camera.

15.6 Augmented Reality flags

ClearCruise™ Augmented Reality displays AIS Targets, Waypoints and Chart Objects as individual Augmented Reality **Flags** in the Video app.

All flags display an icon and your vessel's distance from the target's location.

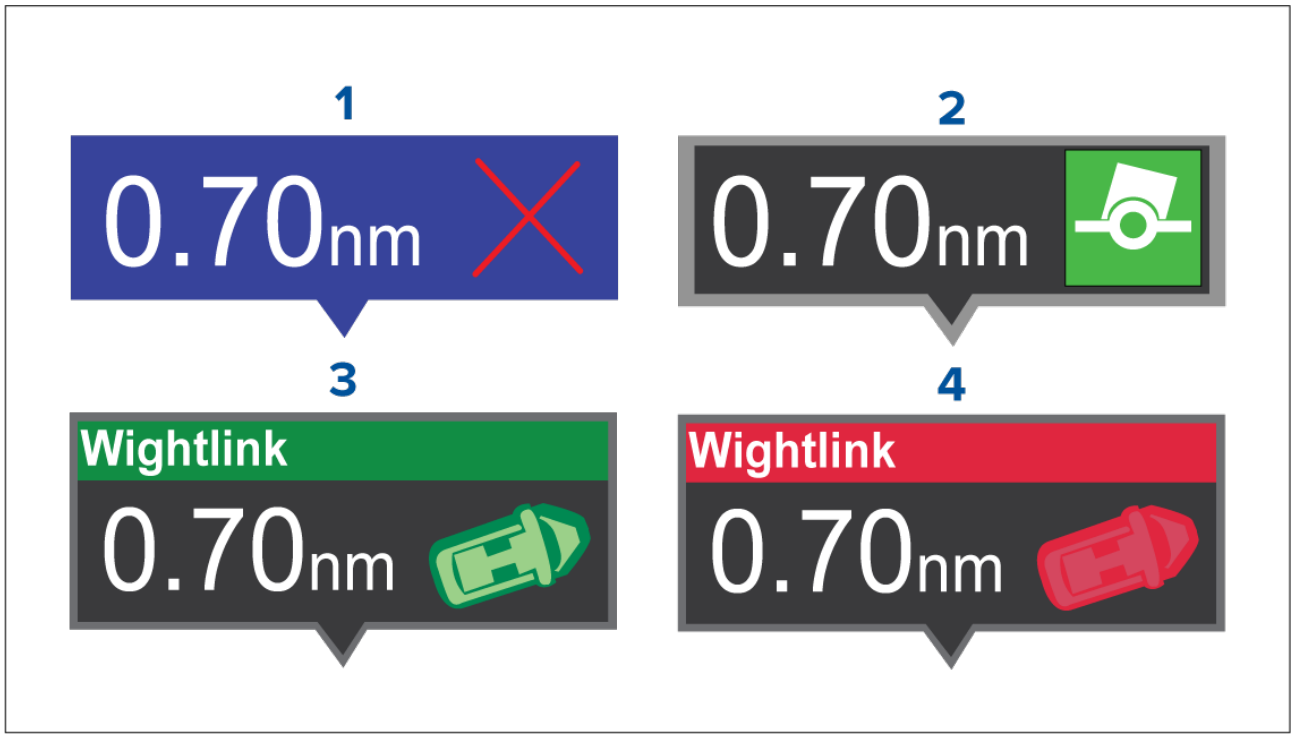

1	Waypoint flag
2	Chart Object flag (buoy)
3	AIS Target flag (passenger ferry; icon points in the direction of travel relative to the camera feed)
4	Dangerous AIS Target flag (passenger ferry; icon points in the direction of travel, relative to the camera feed)

Note: AIS flags update periodically; however, accurate placement is not guaranteed.

- AIS Targets, Waypoints and Chart Object flags can be quickly enabled / disabled via buttons in the Video app.
- The maximum range within which flags are automatically shown can also be adjusted in the Video app.
- For more information on adjusting flag settings, refer to: [15.1 ClearCruise™ features](#)



Selected flags

Augmented Reality flags in the Video app can be selected (highlighted), providing access to more information about the object and additional features.

A flag is an onscreen visual overlay element displayed in the Video app when the Augmented Reality features are enabled. A flag represents an object from the Chart application: e.g. AIS target, Waypoint, or other chart object.

When a flag is selected, the corresponding object is also highlighted in the Chart app. Conversely, selecting an object in the Chart app highlights the corresponding flag in the Video app.

Only one flag may be selected at a time.

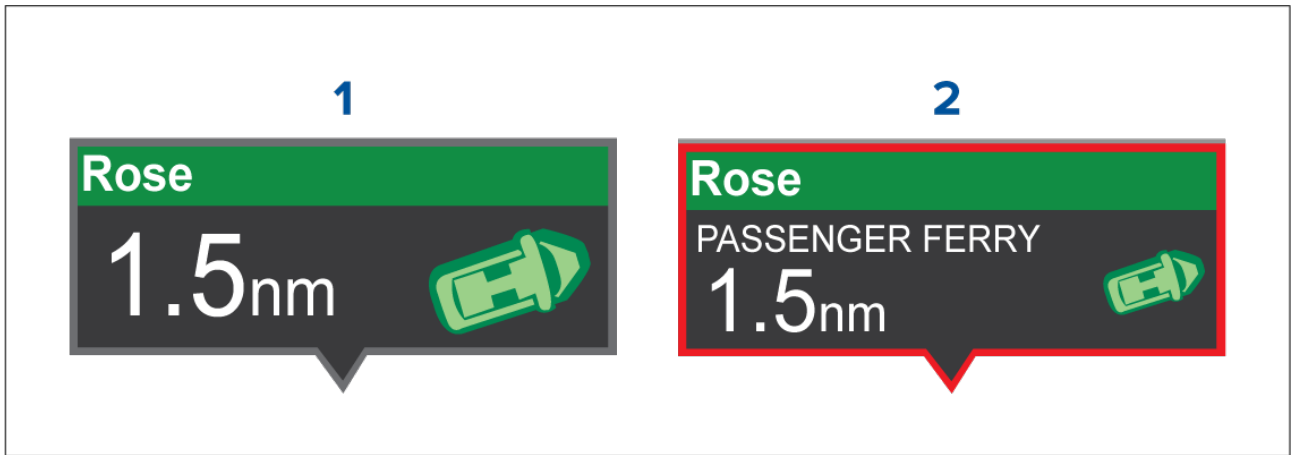

1	AIS Flag
2	Selected AIS Flag



Selecting a flag highlights it in red and provides additional information about the object in a context menu. The menu also provides additional features. The range of features available in the context menu depends on the type of object selected:

AIS Target Flag

Option	Description
AIS Target name	The name of the target vessel.
Target data	Vessel (name), CPA, TCPA, COG, SOG.
View AIS data	Displays the AIS data transmitted by the target vessel.

Option	Description
Buddy (toggle ON/OFF)	Add the vessel to your “Buddy List”, with the option to rename it. The Buddy feature enables you to add AIS-equipped friends and regular contacts to a “Buddy List” on your MFD. As soon as a vessel on your Buddy List comes within range of your AIS receiver, the onscreen vessel icon changes to indicate this.
Goto	The Chart app will plot a direct route to the last known location of the target.
Place waypoint	The Chart app will place a waypoint at the last known location of the target.

Waypoint Flag

Option	Description
Waypoint name	The name of the waypoint.
Target data	Lat, Lon, Rng, Brg.
Goto	The Chart app will plot a direct route to the last known location of the target.
Delete	Delete the waypoint.
Edit	Edit the waypoint’s Name, Symbol, Group, Position, and add a Comment.

Chart Object Flag

Option	Description
Chart Object name	The name of the chart object.
Target data	Lat, Lon, Rng, Brg.
Goto	The Chart app will plot a direct route to the last known location of the target.

Goto flag

Selecting **Goto** on a selected Augmented Reality flag will plot a direct course to the flag’s last known location.

A **Goto** flag will appear in the last known location of the selected flag in both the Video and Chart apps, and in the Video app’s **Compass bar**. The flag is displayed with a Goto icon, as a blue copy of the original flag.

Selecting the **Goto** flag makes it a selected flag, and also displays a context menu providing more information about the location of the flag, and the option to stop a goto action.

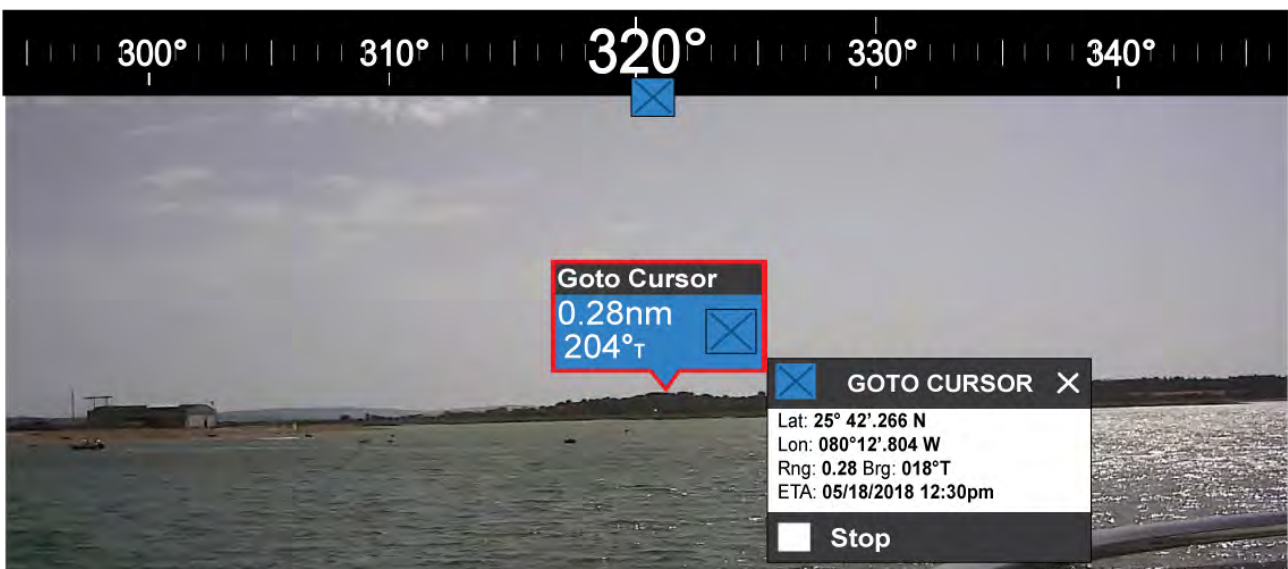

- Selecting **Stop** removes the Goto flag from the Video app and Chart app.
- If the camera loses sight of the **Goto** flag, it will display red and green navigational arrows on the **Compass bar**, indicating whether you need to turn port or starboard to regain sight of the flag. However, this only works if the camera is forward-facing.

15.7 ClearCruise settings (Augmented Reality)

Augmented Reality settings can be edited in the **ClearCruise** tab in the Video app.

Setting	Description
AIS labels	Enables/disables the display of other vessels as Augmented Reality flags (requires AIS).
Hide static targets	Enables/disables the display of AIS targets travelling under 2 knots (requires AIS).
Waypoints	Enables/disables the display of Waypoint Augmented Reality flags.
Chart objects	Enables/disables the display of Chart objects (requires compatible charts).
Cartography source	Select the cartography source that the ClearCruise™ features will use for the display of chart objects in the Video app Augmented Reality features. (Requires compatible charts).
Compass	Enables/disables the display of the Compass bar in the Video app.
Range limit	Sets the maximum range at which the camera will detect and display Augmented Reality flags. This range is displayed visually in the Chart app with the “FOV cone”. Refer to: Field of View . For the maximum range supported by your camera, refer to: Range limit

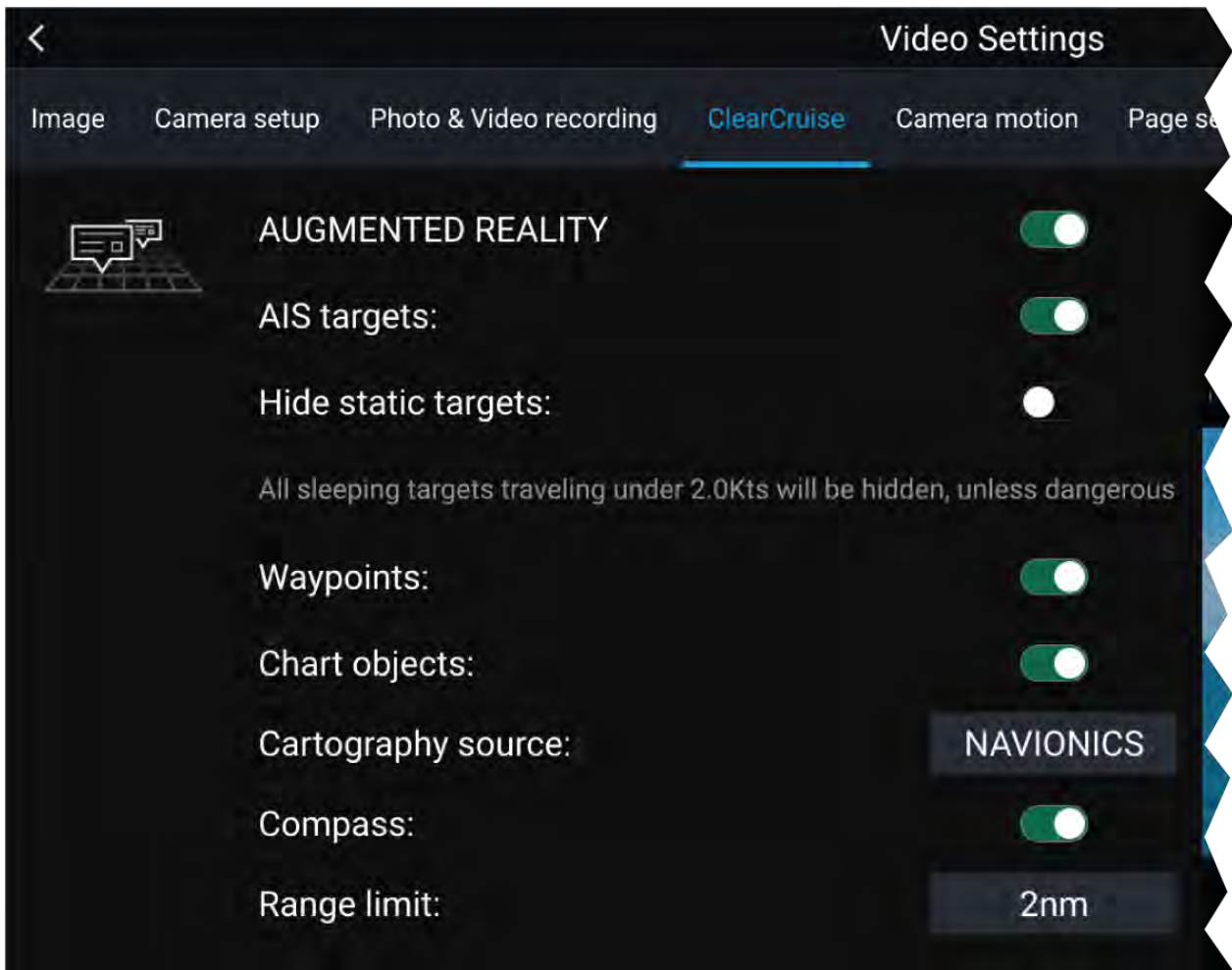

Note:

The variety of chart objects is dependent on the selected cartography source. For more information on different cartography sources, refer to: [8.11 Find nearest](#)

Range limit

The Range Limit is the maximum range at which ClearCruise™ can display AIS targets, Waypoints and Chart Object flags in the Video app.

The range limit can be checked using the Field of View (FOV) cone in the Chart app. All AIS targets, Waypoints and Chart Objects within the area of coverage of the FOV cone can be displayed as Augmented Reality flags in the Video app. For more information, refer to: [Field of View](#)

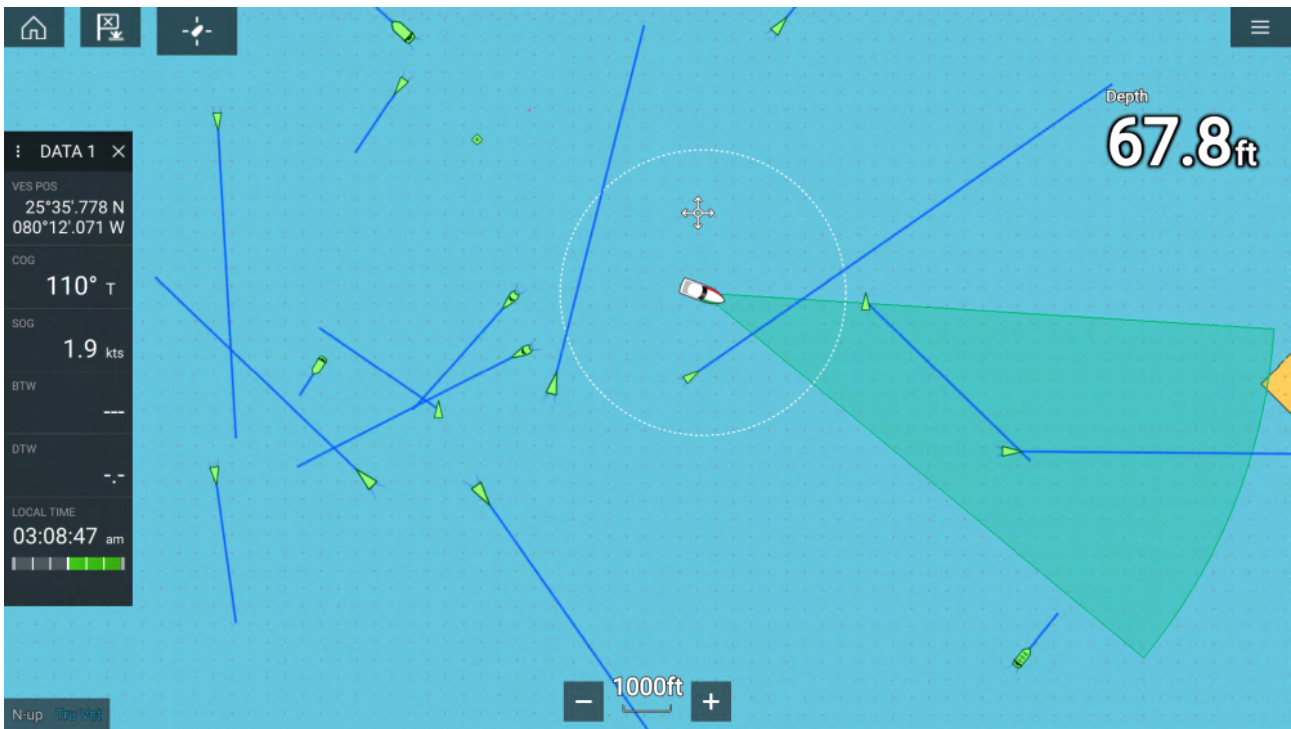

Note:
Some chart objects just outside of the FOV cone might still display in the Video app as flags.

You can specify this range limit manually in the Video app: **Video Settings > ClearCruise tab**. Any adjustments you make will be reflected in the FOV cone display in the Chart app.

15.8 Roll correction

Roll Correction automatically adjusts the Video app image when the vessel tilts (rolls) to port or starboard.

Note: Roll correction is only available with IP cameras.

Roll Correction can be enabled/disabled in the Video app: **Settings > Image**.

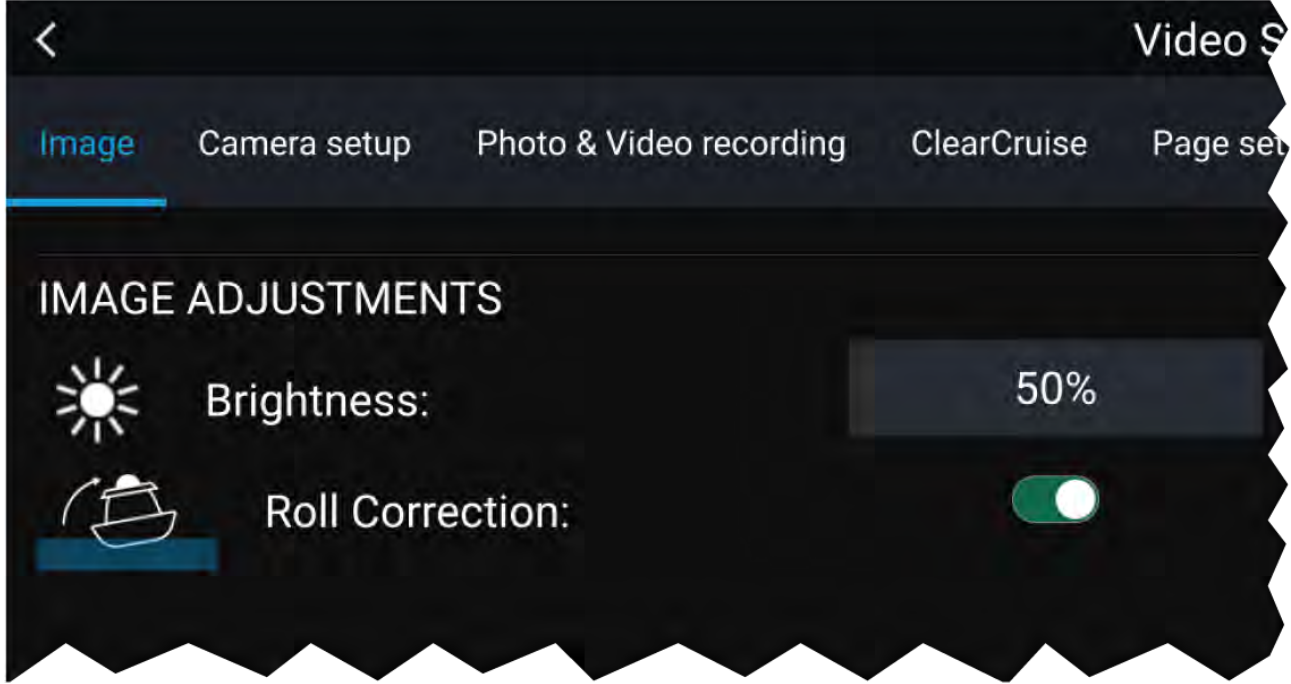

When enabled, the Roll Correction feature accounts for the boat tilting and stabilizes the video feed accordingly. This means that the video feed's horizon will be parallel with the actual horizon. When disabled, the video feed will tilt with the boat and the MFD screen.



1	Roll correction disabled
2	Roll correction enabled

15.9 AR200 Calibration (Linearization)

To enable accurate placement of Augmented Reality (AR) flags on the camera's video feed, the AR200's AHRS sensors need to compensate for local magnetic fields, as well as the Earth's magnetic fields.

Calibration is achieved using an automatic linearization process. The linearization process starts automatically after your vessel has turned approximately 100°, when travelling at a speed of between 3 to 15 knots. The linearization process requires no user input, however at least a 270° turn is required before linearization can be completed. The duration of the linearization process can be decreased by completing a full 360° turn, when travelling at a speed of between 3 to 15 knots. The linearization process can also be restarted at anytime.

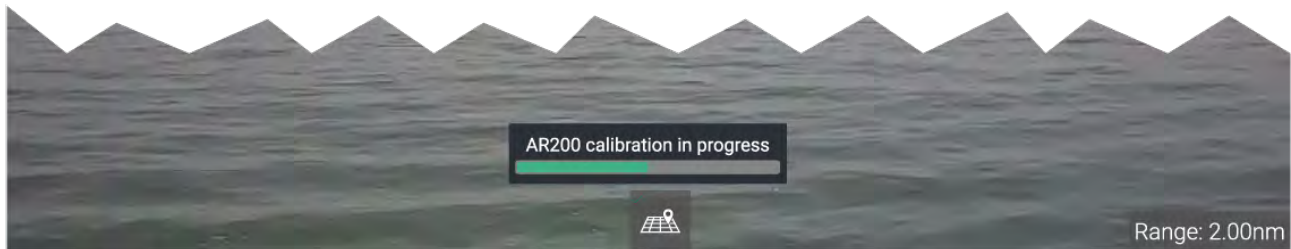

In the Video app the Linearization progress bar is displayed when linearization is in progress. The bar is filled to indicate completeness, and will turn Red if the process is paused or otherwise interrupted.

The time taken to complete the linearization process will vary according to the characteristics of the vessel, the AR200's installation location, and the levels of magnetic interference present at the time linearization is performed.

Magnetic interference can be caused by objects onboard your vessel, such as:

- Speakers
- Electronic equipment
- Electrical cabling
- Metal bulkhead or hull

Magnetic interference can also be caused by external objects in close proximity to your vessel, such as:

- Metal hulled vessels
- Underwater electrical cables
- Marine pontoons

Magnetic deviation

Magnetic deviation is the error induced in a compass caused by interference from local magnetic fields.

The automatic linearization process results in a deviation value being set for your AR200. If Augmented Reality flags in the Video app are not aligned with their onscreen objects, or the compass is out of alignment, you should check the AR200's current calibration settings. For instructions on how to do this, refer to: [AR200 calibration settings](#)

AR200 calibration settings

The calibration settings page provides access to the AR200's compass calibration options.

The AR200 calibration page can be accessed using your Data master MFD; from the Homescreen select: **Settings > Network > Data sources > Heading > AR200 > Calibrate.**

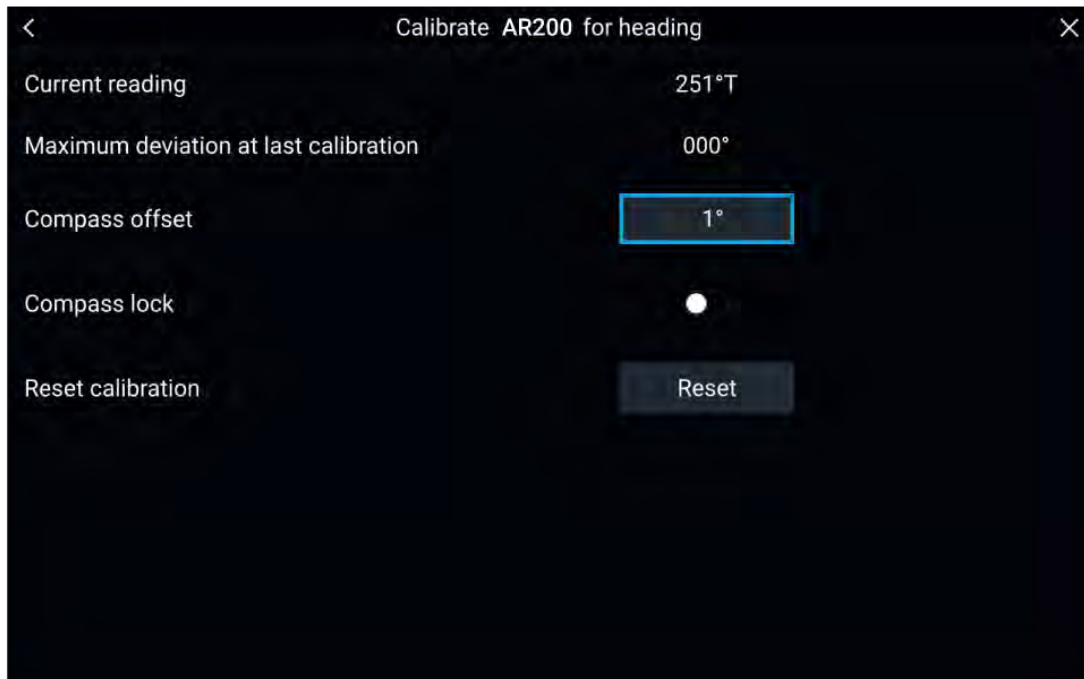

1	<p>Current reading: The current heading reported by the AR200.</p>
2	<p>Maximum deviation at last calibration: The maximum deviation reported during the last linearization process.</p> <div style="border: 1px solid black; padding: 5px;"> <p>Important:</p> <ul style="list-style-type: none"> • If the Maximum deviation at last calibration is 45° or above, it is recommended that the AR200 unit is moved and re-installed in a location which is subject to less magnetic interference. </div> <p>Calibration in progress: While linearization is in progress the progress percentage is displayed.</p>
3	<p>Compass offset Once the linearization process has completed, it is possible that the heading value may be slightly out of alignment. This is common where installation space is limited and the AR200 is not properly aligned with your vessel's longitudinal axis. In this case, it is possible to manually adjust the Compass offset.</p>
4	<p>Compass lock When enabled, the Compass lock prevents the continual monitoring and adaptation of the compass linearization process. For more information, refer to: Compass lock.</p>
5	<p>Reset calibration You can reset your AR200's current linearization settings by selecting Reset calibration</p>

Continual monitoring and adaptation

To ensure optimum performance, after the initial linearization process is complete the unit continues to monitor and adapt the compass linearization to suit current conditions.

If the conditions for linearization are less than ideal, the automatic linearization process temporarily pauses until conditions improve again. The following conditions can cause the linearization process to temporarily pause:

- significant magnetic interference is present
- vessel speed too slow or too fast
- rate-of-turn too slow or too fast

Compass lock

Once you are satisfied with the compass accuracy, you can lock the setting to prevent the autopilot system from completing a further automatic linearization in the future.

This feature is particularly useful for vessels in environments that are exposed to strong magnetic disturbances on a regular basis (such as offshore wind farms or very busy rivers, for example). In these situations it may be desirable to use the Compass lock feature to disable the continuous linearization process, as the magnetic interference may build a heading error over time.

Note: The compass lock may be released at any time, to allow the compass continual monitoring and adaptation to re-commence. This is particularly useful if planning a long voyage. The earth's magnetic field will change significantly from one geographical location to another, and the compass can continually compensate for the changes, ensuring you maintain accurate heading data throughout the voyage.

Chapter 16: Audio app

Chapter contents

- [16.1 Audio app overview on page 294](#)
- [16.2 Opening the Audio app on page 298](#)
- [16.3 Getting started on page 300](#)
- [16.4 Audio app menu options on page 302](#)

16.1 Audio app overview

The Audio app can be used to control compatible entertainment systems that are connected to the same network as your MFD.

The Audio app can be displayed in Fullscreen and half screen portrait app pages.

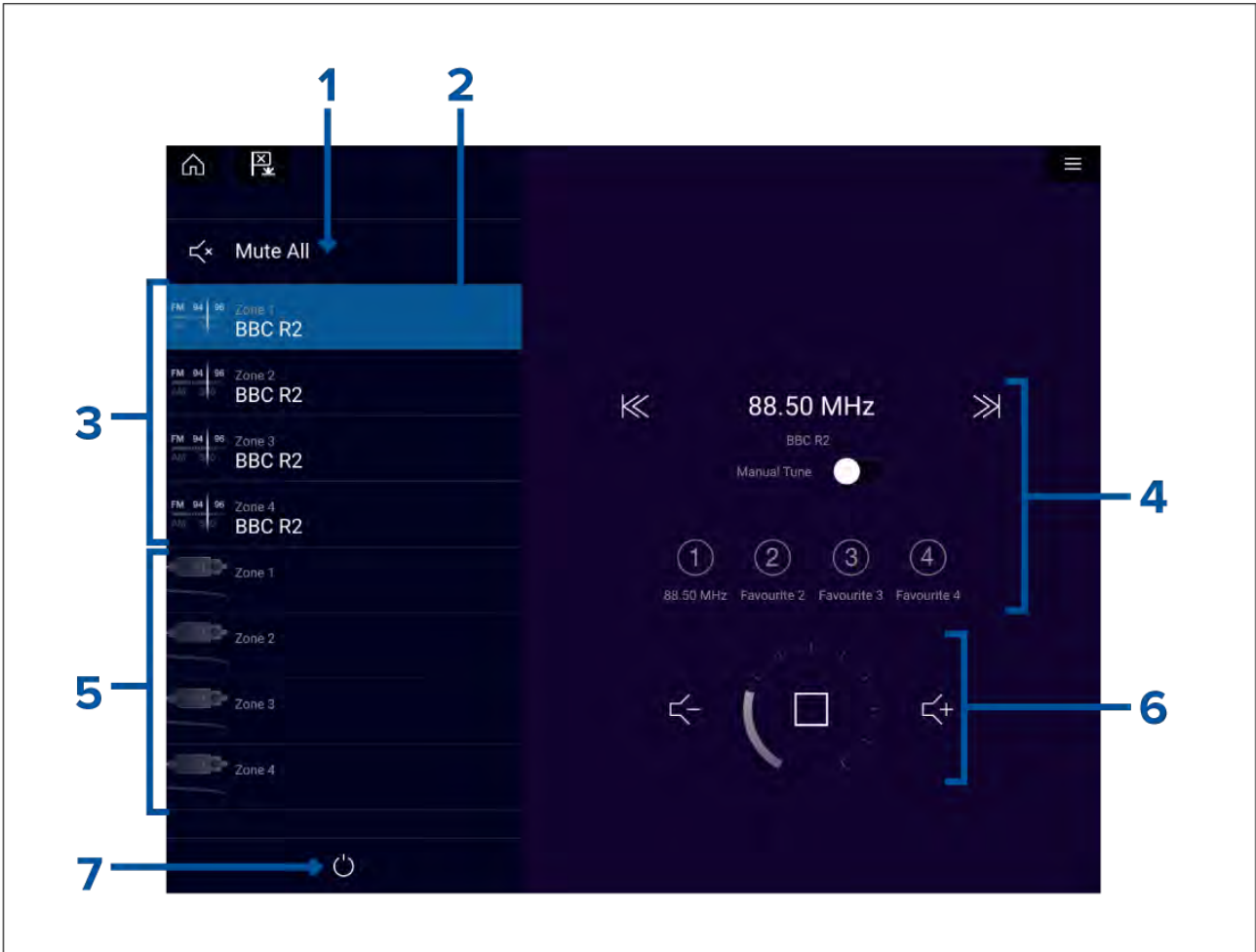

1. **Mute All** — Mutes all zones on the currently selected system.
2. Currently selected zone.
3. System 1 available zones.
4. Audio source and controls for currently selected zone.
5. System 2 available zones.
6. Zone volume and player controls for currently selected zone.
7. **Power** — Power on or off connected entertainment systems.

Compatible entertainment systems

The table below lists compatible entertainment systems which have been approved for use with the MFD Audio app. The Audio app can be used to control up to 3 entertainment systems from the same manufacturer. However, connecting entertainment systems from Fusion and Rockford Fosgate at the same time is NOT supported.

SiriusXM receivers

Model number	Raymarine part number	Supported Network connection
SR150	E70161	Ethernet / RayNet
SR200	E70499	Ethernet / RayNet

Rockford Fosgate entertainment systems

Model number	Raymarine part number	Supported Network connection
RMX-2	E70397	NMEA 2000
RMX8DH	E70394	NMEA 2000
RMX8BB	E70395	NMEA 2000
RMX5CAN	E70396	NMEA 2000

Fusion entertainment systems

Model number	Supported Network connection
AV750	NMEA 2000 Ethernet
AV755	NMEA 2000 Ethernet
BB100	NMEA 2000
BB300	NMEA 2000
RA70	NMEA 2000
RA70N	NMEA 2000
RA205	NMEA 2000
RA670	NMEA 2000 Ethernet
RA770	NMEA 2000 Ethernet
SRX400	Ethernet
UD750	NMEA 2000 Ethernet
UD755	NMEA 2000 Ethernet

JL Audio









Model number	Supported Network connection
MM50	NMEA 2000
MM100s-BE	NMEA 2000
MMR-40	NMEA 2000







Note:

Connecting entertainment systems from Fusion and Rockford Fosgate at the same time is not supported.



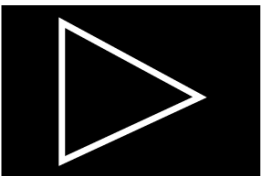

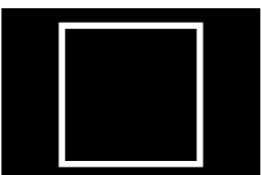
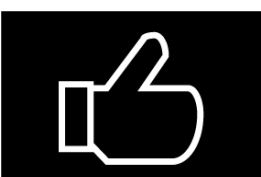
Audio app controls

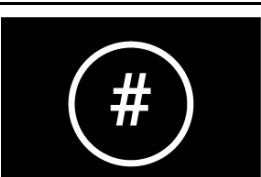
Audio player controls

Icon	Description	Function
	Power Off	Powers off the Entertainment system.
	Mute All	Mutes all audio zones.
	Volume Down	Decreases volume for current zone.
	Volume Up	Increases volume for current zone.
	Forwards	<ul style="list-style-type: none"> • Skip to the next track (USB and Bluetooth) • Seek/Search Forward (Radio) <div style="border: 1px solid black; padding: 2px;">Note: For SiriusXM, channel control is not available from an external audio head unit.</div>
	Backwards	<ul style="list-style-type: none"> • Skip back to beginning of current track (USB and Bluetooth) • Seek/Search Backward (Radio) <div style="border: 1px solid black; padding: 2px;">Note: For SiriusXM, channel control is not available from an external audio head unit.</div>
	Manual Tune	<ul style="list-style-type: none"> • On (switches Forwards and Backwards icons with Manual Tune icons) • Off
	Tune Up	Manually searches up for radio stations/channels. <div style="border: 1px solid black; padding: 2px;">Note: For SiriusXM, channel control is not available from an external audio head unit.</div>
	Tune Down	Manually searches down for radio stations/channels. <div style="border: 1px solid black; padding: 2px;">Note: For SiriusXM, channel control is not available from an external audio head unit.</div>

Icon	Description	Function
	Repeat	<ul style="list-style-type: none"> • Off • Repeat Track • Repeat All
	Shuffle	<ul style="list-style-type: none"> • On • Off
	Play	Select to commence playback.
	Pause	Select to Pause playback.
	Stop	Select to Stop (Mute) Radio devices.
	Like	Like a track (Pandora only).
	Dislike	Dislike a track (Pandora only).
	Radio presets	<p>Save your favorite radio stations/channels to 4 preset buttons. Press and hold to save, press once to change to saved station/channel.</p> <div style="border: 1px solid black; padding: 5px;"> <p>Note: For SiriusXM, channel control is not available from an external audio head unit.</p> </div>

Standard app controls

Icon	Description	Function
	Menu icon	Opens the app menu.
	Home icon	Takes you to the Homescreen.
	Waypoint / MOB	Place waypoint / activate Man overboard (MOB) alarm.
	Pilot icon	Opens and closes the Pilot Sidebar

16.2 Opening the Audio app

The Audio app is opened by selecting an app page from the Homescreen that includes the Audio app.

Pre-requisites:

1. Ensure your Entertainment system(s) are compatible by checking the latest details available on the Raymarine website. If in doubt please contact an authorized Raymarine dealer for advice.
2. Ensure you have installed your Entertainment system(s) in accordance with the documentation that was supplied with the system.

The Audio app will open in 1 of 3 states:

Audio app displayed

If your Entertainment system is powered up and operational then the player controls are displayed and can be used to control your system.

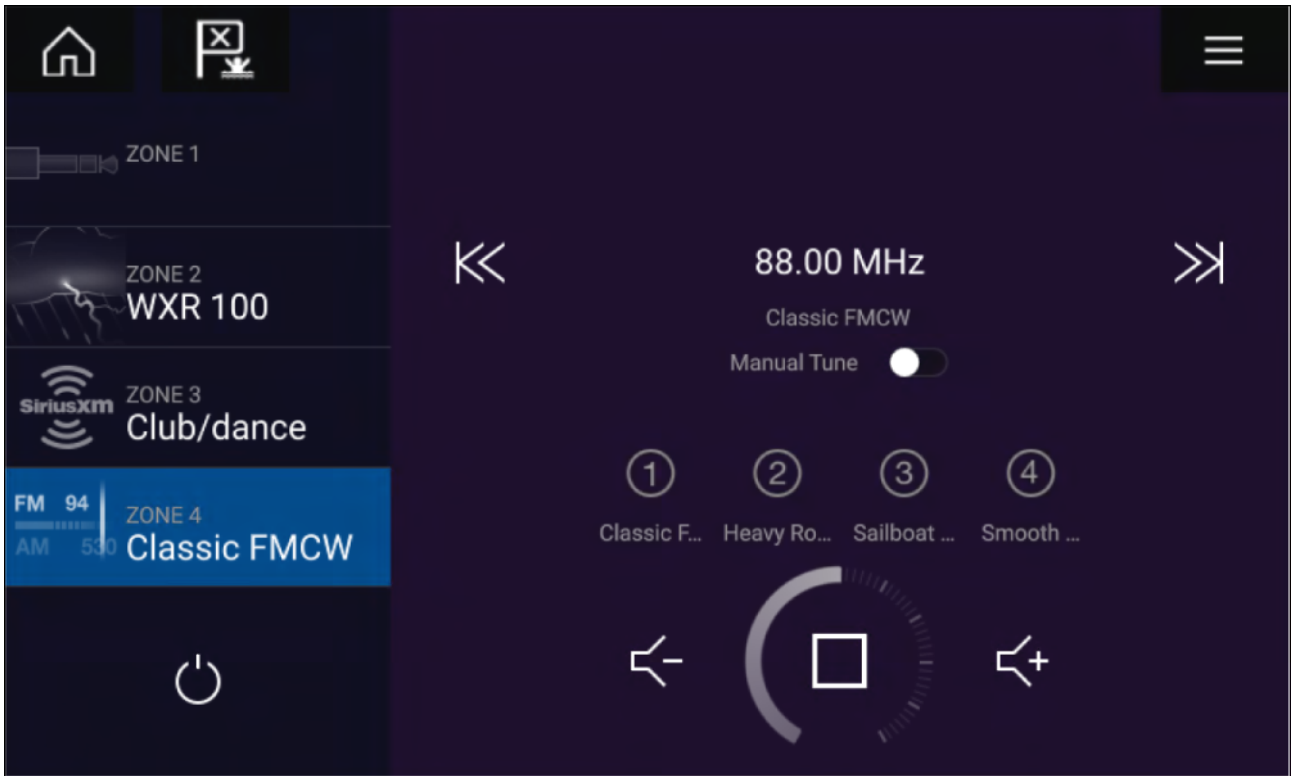

Entertainment system powered off

If all Entertainment systems are powered off then a Power icon is displayed for each connected system. An icon is also displayed to power on All systems. Selecting the **Power icon** will switch your Entertainment system on. Selecting the All icon will power on all connected systems.

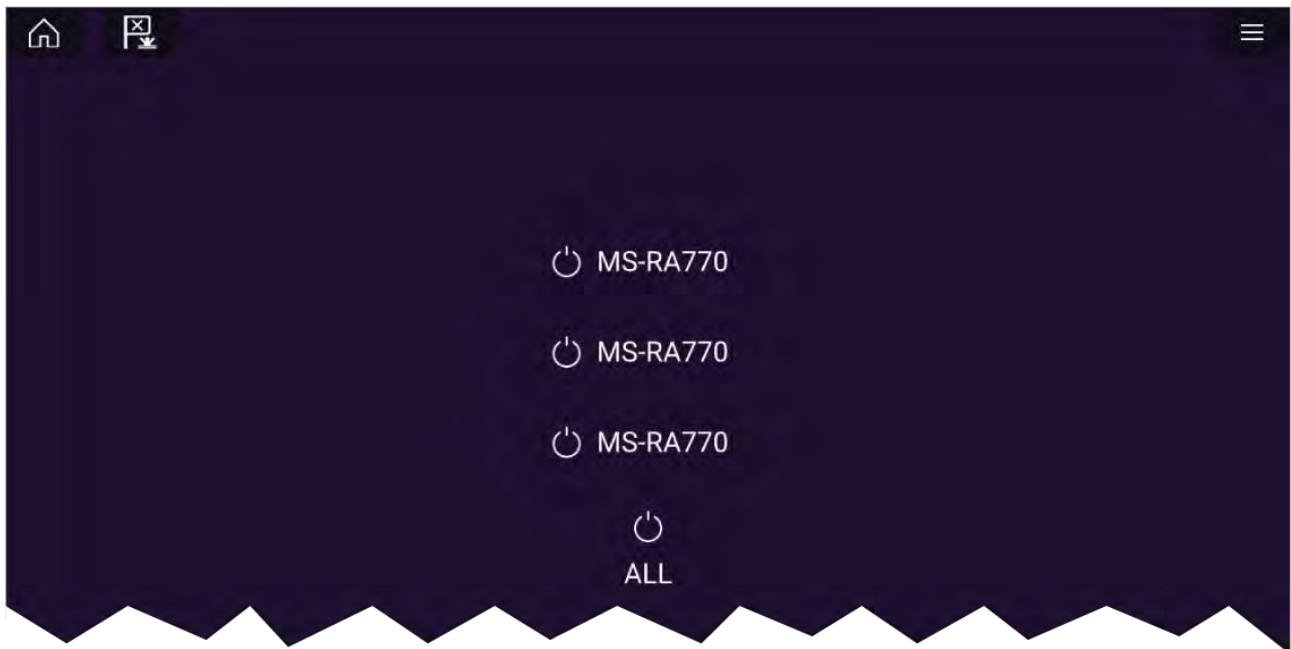

No audio devices found

If the Audio app is opened soon after powering on your MFD, the ‘**No audio device found**’ message may be displayed whilst the network is being established. If the message is displayed for more than 10 seconds, your MFD cannot connect to your Entertainment system(s). Ensure network and power connections to your Entertainment system(s) and MFD are correct and free from damage and then power cycle your system. If the Entertainment system(s) are still not displayed then refer to your equipment’s installation documentation for further troubleshooting information.

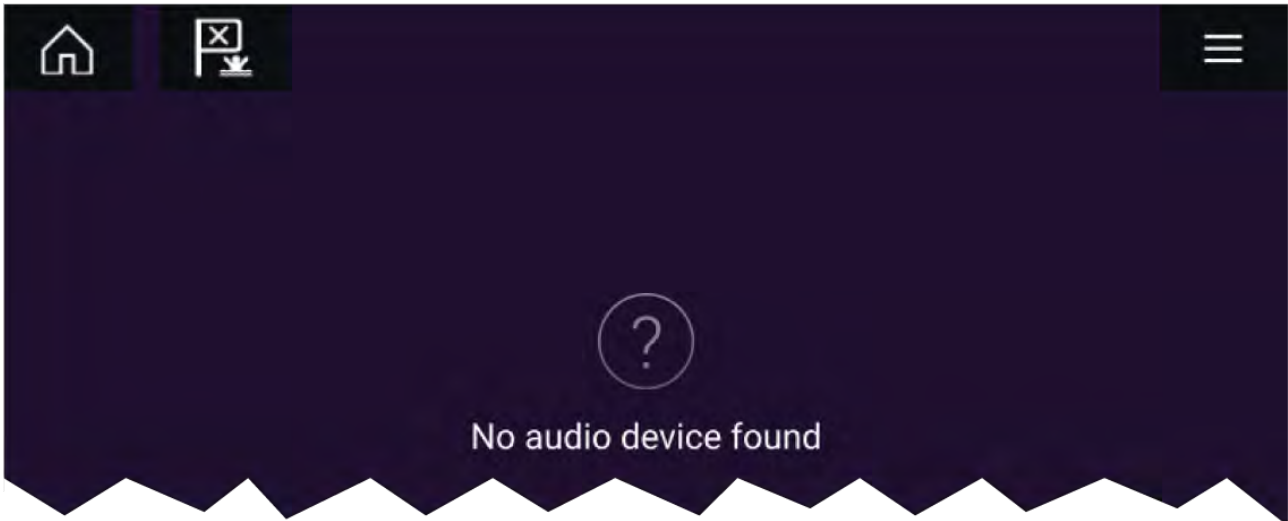

16.3 Getting started

Selecting an audio zone

If you have more than 1 zone configured, audio zones will be displayed on the left side of the screen. All zones for all connected systems will be displayed, grouped by entertainment system.

1. Select the required zone.

Details of the audio source playing in that zone are displayed along with audio controls.

Tip

Refer to the instructions provided with your entertainment system for details on naming your zones. This aids device and zone identification when multiple systems each with multiple zones are connected.

Selecting an audio source

Before you can select an audio source from your MFD, the source must already be available to your Entertainment system's main control unit ("head unit").

1. Select an audio source (mode) icon from the app **Menu**.

The currently selected zone will switch to the selected audio source. Depending on your entertainment system all zones will change and play the same audio source, or you may be able to play a different source on each zone. Check the instructions provided with your system for details.

Muting and unmuting

1. To mute the audio for all zones on all connected systems, select **Mute All**, located above the zones on the top left of the screen.

*When multiple systems are connected selecting **Mute all** will mute all zones on all connected entertainment systems.*

2. To Unmute a device select a zone for that device and then select **Unmute**.

*Selecting **Unmute** will unmute all the zones for the selected entertainment system.*

Browsing for tracks

You can browse USB and Bluetooth devices for tracks.

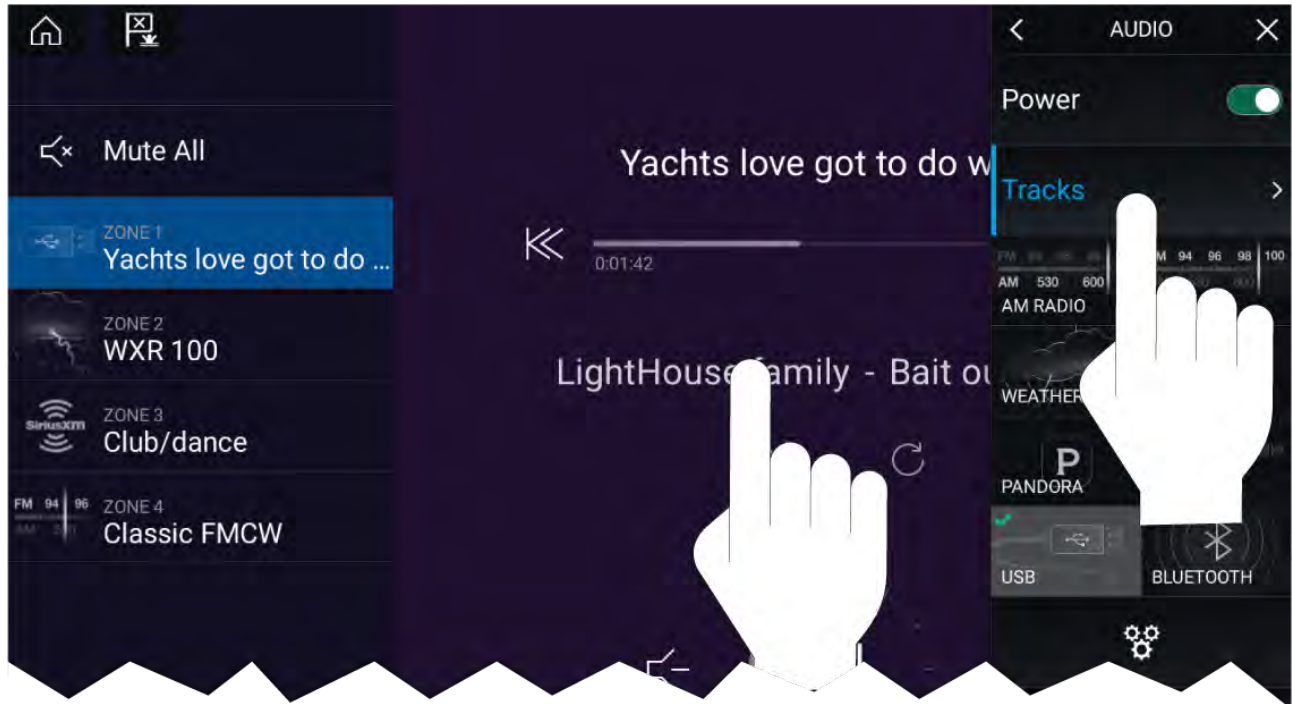

With the relevant USB or Bluetooth device selected as the audio source:

1. Select **Tracks** from the Menu.
The file browser is displayed.
2. Alternatively, you can select the current track's details to open the file browser.
3. Browse to the file you want to play.

Wait for the file list to finish loading before selecting a track.

4. Select the track you want to play.

Browsing for stations / channels

You can browse available Radio stations/channels.

With the relevant Radio device selected as the audio source:

1. Select **Stations** or **Channels** from the Menu.
The station or channel browser is displayed.
2. Browse to and select the station or channel you want to listen to.

Note: For SiriusXM, channel control is not available from an external audio head unit.

Saving presets

Up to 4 presets can be saved for each Radio audio source (i.e.: AM Radio, FM Radio, Weather, SiriusXM and Pandora).

1. Whilst listening to the station you want to save, press and hold the relevant Preset button for approximately 3 seconds.

Powering off entertainment systems

Connected entertainment systems can be powered off using the Audio app.

With the Audio app displayed and the entertainment system powered on:

1. Select the **Power** icon located on the bottom left of the screen.
If only 1 entertainment system is connected then the entertainment system will power off. If more than 1 entertainment system is connected then pop-over options are displayed allowing you to choose the entertainment system to turn off, or you can select **Power down all** to power off all connected systems.

Tip

Refer to the instructions provided with your entertainment system for details on naming your device. This aids device identification when multiple systems are connected.

16.4 Audio app menu options

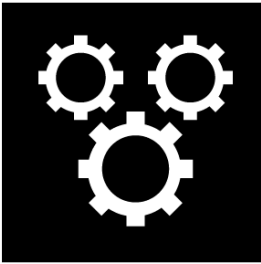
Menu item	Description	Options
Tracks	Enables you to browse for tracks on USB/Bluetooth devices connected to your Entertainment system	<ul style="list-style-type: none"> • Folder • Play Queue
Channels	Provides a list of available SiriusXM channels <div style="border: 1px solid black; padding: 2px; margin-top: 5px;"> Note: For SiriusXM, channel control is not available from an external audio head unit. </div>	Channel list
Stations	Provides a list of available Pandora stations	Station list
Audio sources	Enables you to select an audio source connected to your Entertainment system	<ul style="list-style-type: none"> • AM Radio • FM Radio • Weather • Sirius XM • Pandora • Auxiliary • USB • Bluetooth • Airplay • S/PDIF
Power	Enables you to Power your Entertainment system on and off	<ul style="list-style-type: none"> • On • Off
	Displays the Settings page	<ul style="list-style-type: none"> • Audio setting • Page settings

Audio app settings menu

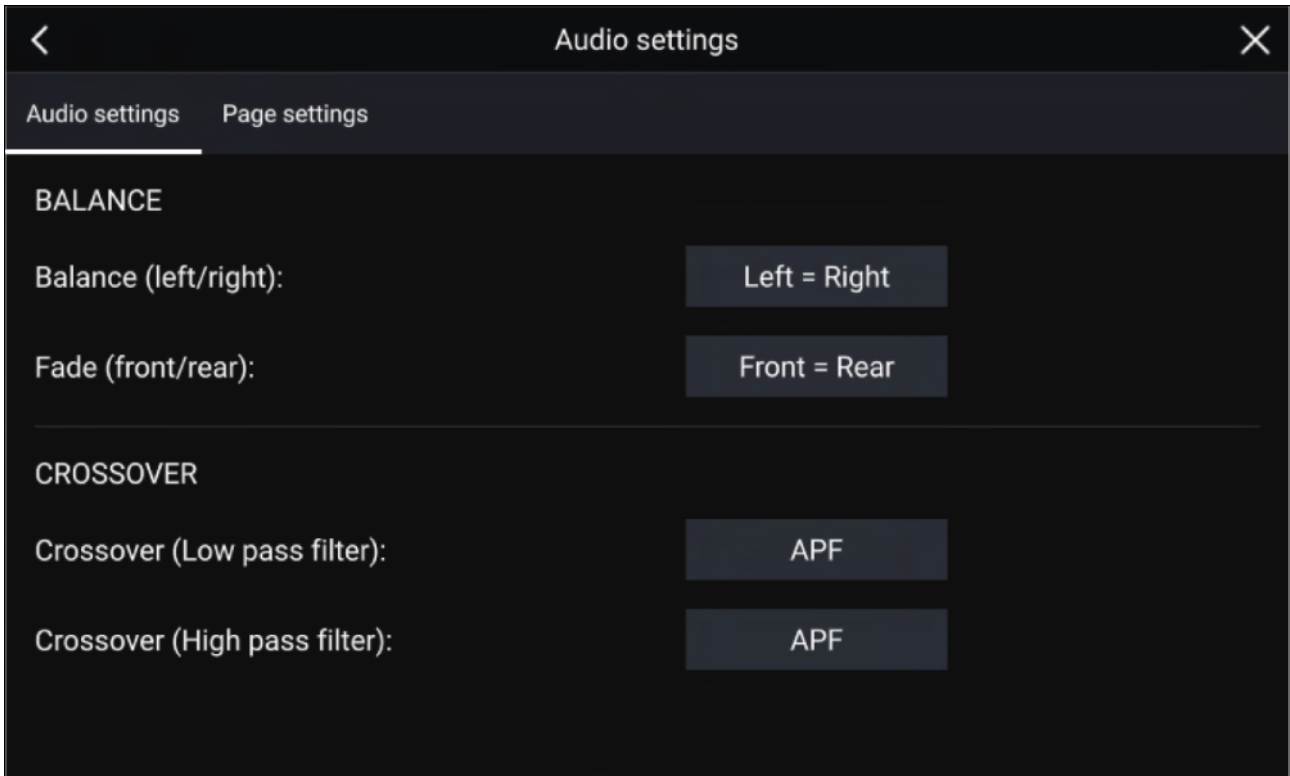

Audio settings tab

Menu item	Description	Options
Balance	Allows you to control the left / right speaker balance of your entertainment system speakers.	<ul style="list-style-type: none"> • L = Left speakers up to 100% • Left = Right (Balance centered) • R = Right speakers up to 100%
Fade	Allows you to control the front / back speaker fade of your entertainment system speakers. <div style="border: 1px solid black; padding: 5px; margin-top: 10px;"> <p>Note: Only available on Rockford Fosgate entertainment systems.</p> </div>	<ul style="list-style-type: none"> • F = Front speakers up to 100% • Front = Back (Fade centered) • R = Rear speakers up to 100%
Crossover (Low pass filter):	Allows you to select the crossover frequency. The Low Pass Filter (LPF) will block all audio frequencies above the threshold you specify. Selecting APF (All Pass Filter) will allow all frequencies.	<ul style="list-style-type: none"> • 60 Hz • 80 Hz • 120 Hz • APF
Crossover (High pass filter):	Allows you to select the crossover frequency. The High Pass Filter (HPF) will block all audio frequencies below the threshold you specify. Selecting APF (All Pass Filter) will allow all frequencies.	<ul style="list-style-type: none"> • 60 Hz • 80 Hz • 120 Hz • APF

Menu item	Description	Options
Multi-zone volume control:	Allows you to select independent audio zones that are controlled by multi-zone volume control. Note: Only available on Fusion audio devices with multi-zone control.	<ul style="list-style-type: none"> • Audio zones 1–12
Reset:	Performs a factory reset and power cycle of the SR200. Note: Only available on Sirius SR200 devices.	<ul style="list-style-type: none"> • Reset
Diagnostics mode:	Displays the SR200's diagnostic information. Note: Only available on Sirius SR200 devices.	<ul style="list-style-type: none"> • Display diagnostics

Page settings tab

Settings	Description
Data Overlays	Enables configuration of Data overlays
Edit split ratio	Enables you to customize the position of the partitions in splitscreen app pages.

Adjusting balance and fade controls

From the **Audio settings** menu: **Menu > Audio settings**

1. Select the **Balance** setting field or the **Fade** setting field.
The Adjustment slider control is displayed.
2. Place your finger on the White marker and then slide it left or right to adjust the setting the required value, alternatively use a **Rotary controller** to adjust the setting the required value.

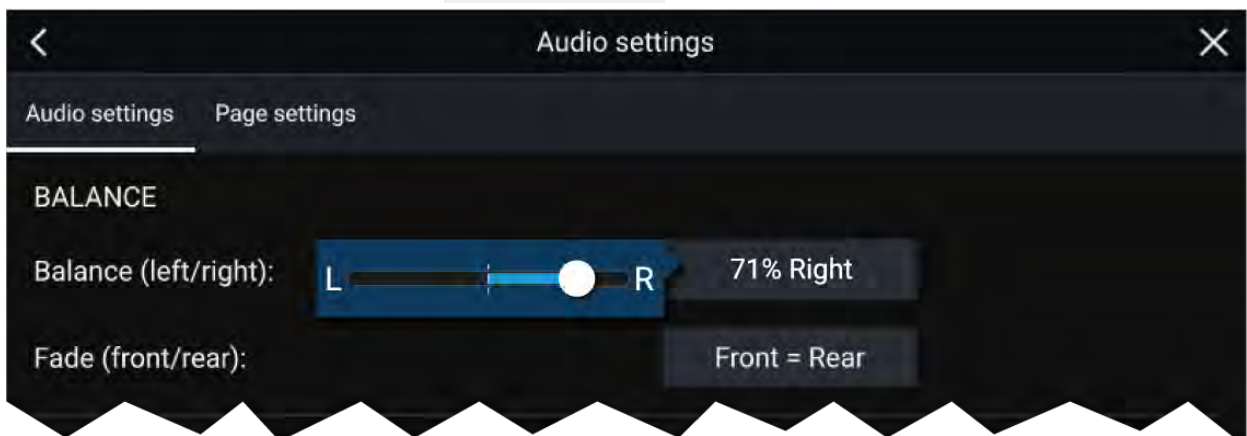

Note:
Fade controls are only available on Rockford Fosgate entertainment systems.

Adjusting multi-zone controls

From the **Audio settings** menu: **Menu > Audio settings**

1. You can choose which **audio zones** you want to change the volume of with **multi-zone control** by selecting them from the list.



2. **Multi-zone volume** is adjusted from the Audio app home screen. Multi-zone volume control is enabled by pressing the multi-zone button (the volume dial will turn purple), all volume changes will affect audio zones selected from the **Audio settings**.

Note:

Multi-zone controls are only available on Fusion entertainment systems.

SR200 diagnostics mode

The SR200 diagnostic mode can be accessed from the audio settings menu from the master MFD on the network. The diagnostics mode should be referred to when liaising with Sirius product support.

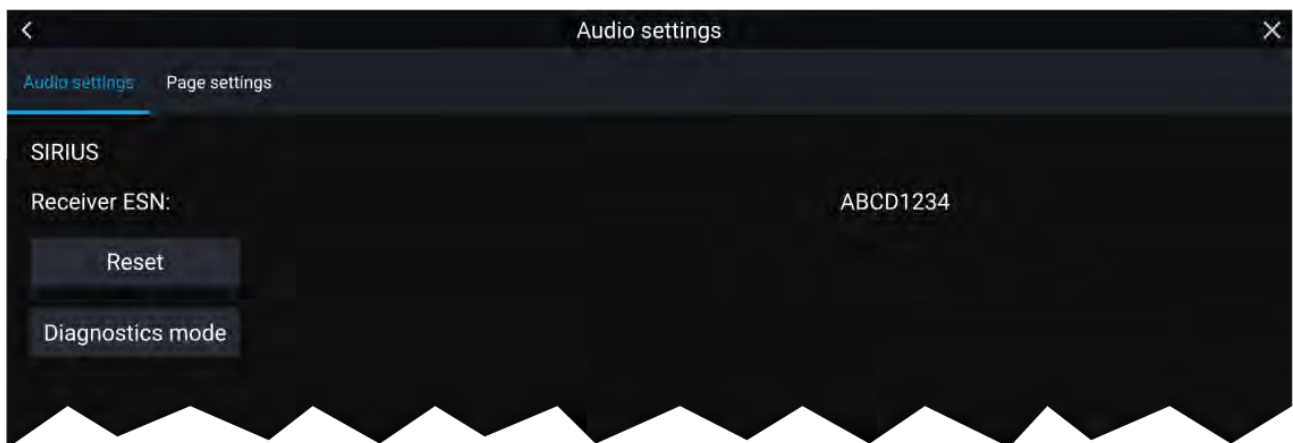

1. Reset — Performs a factory reset and power cycle of the SR200.
2. Diagnostics mode — Displays the SR200's diagnostic information.

Chapter 17: PDF Viewer app

Chapter contents

- [17.1 PDF Viewer app overview on page 308](#)
- [17.2 Opening PDF files on page 308](#)
- [17.3 PDF Viewer controls on page 308](#)
- [17.4 Searching a PDF on page 310](#)

17.1 PDF Viewer app overview

The PDF Viewer app can be used to browse and open PDF files located on your external storage device(s).

A typical use for the PDF viewer is to display Raymarine product handbooks that you have downloaded from the Raymarine website (www.raymarine.com/manuals). PDF files must first be copied to a MicroSD card using an external device (such as a PC or tablet). You can then insert the MicroSD card into your MFD's card slot, and access the PDF file(s) via the PDF Viewer app.

Note:

- The PDF Viewer app requires Lighthouse software version 3.10 or later.
- Secured PDF documents (encrypted with certificate or password) are not supported.

17.2 Opening PDF files

When opened, the PDF Viewer app allows you to browse PDF files available on your external storage device(s).

Select **Browse** to open a PDF file.

Recently-viewed files are displayed on the right-hand side of the initial app start screen, for quick access. These files can be opened, pinned to the top of the list, or removed from the list.

To access these options, long-hold touch on a filename to display the context menu.

Note:

- Recent files cannot be opened if the files are deleted or the external storage device is removed.
- A maximum of 15 of the most recent files can be shown in the pinned and unpinned recent files list.

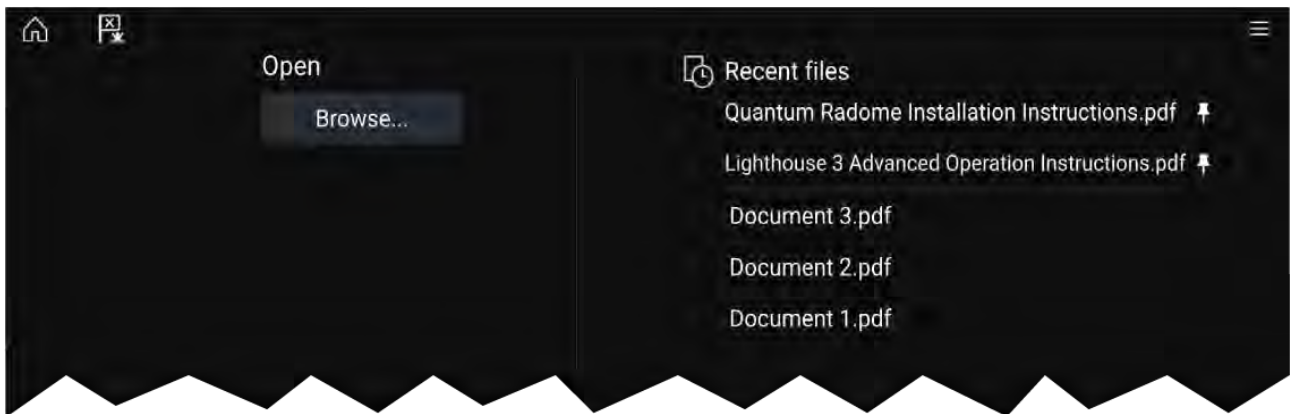

17.3 PDF Viewer controls

When a PDF file is displayed in the PDF Viewer app, the following options are available.

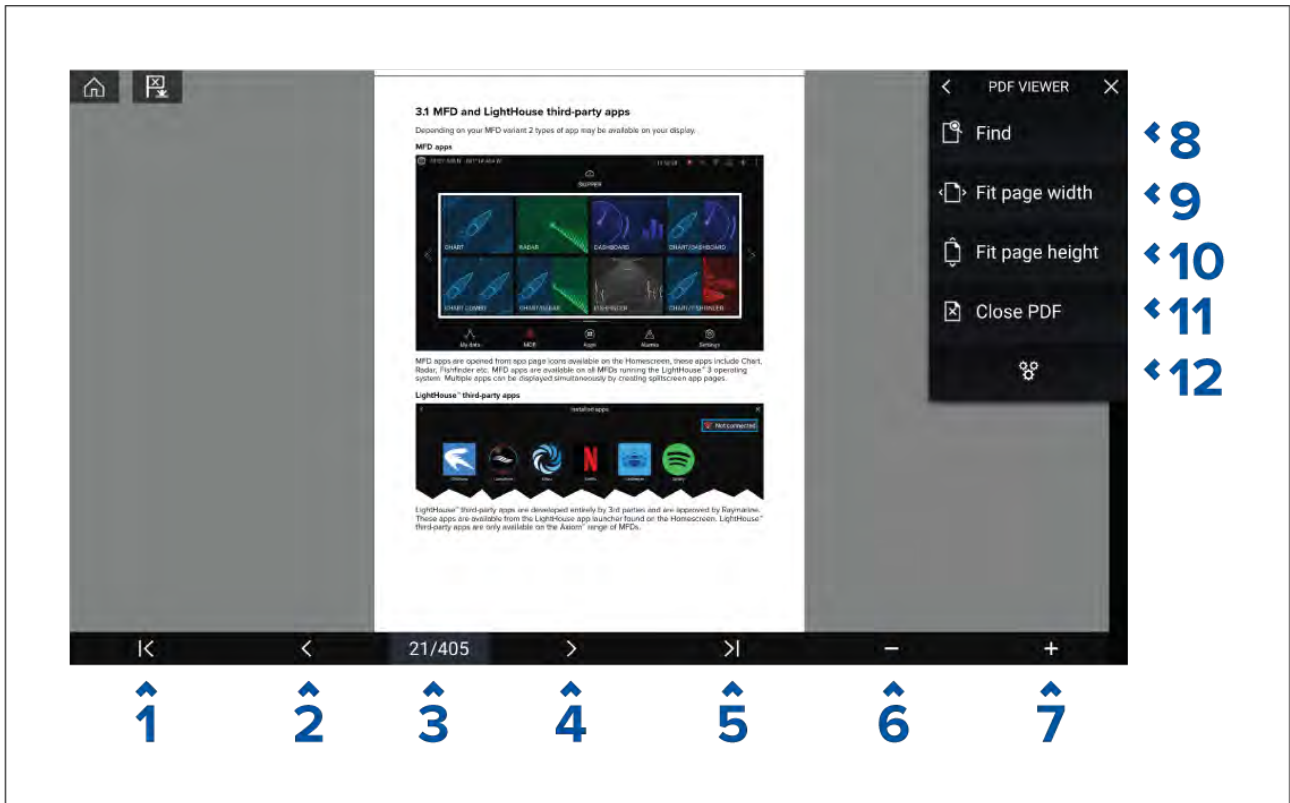

1. **First page** — Select to display the first page of the PDF document.
2. **Page back** — Select to display the previous page.
3. **Pages** — Indicates current page and total number of pages. You can also tap this element and enter a specific page number.
4. **Page forward** — Select to display the next page.
5. **Last page** — Select to display the last page of the PDF document.
6. **Zoom out** — Select to zoom out, in 10% increments.
7. **Zoom in** — Select to zoom in, in 10% increments.
8. **Find** — Select to display the onscreen keyboard and enter a search word or phrase.
9. **Fit page width** — Zoom the document display to fit the width of the PDF page.
10. **Fit page height** — Zoom the document display to fit the height of the PDF page.
11. **Close PDF** — Closes the PDF and displays the initial PDF Viewer app start screen.
12. **Settings** — Displays the Settings menu, which allows you to add data overlays to the PDF Viewer app.

17.4 Searching a PDF

You can search a PDF document for a word or phrase using the Find function.

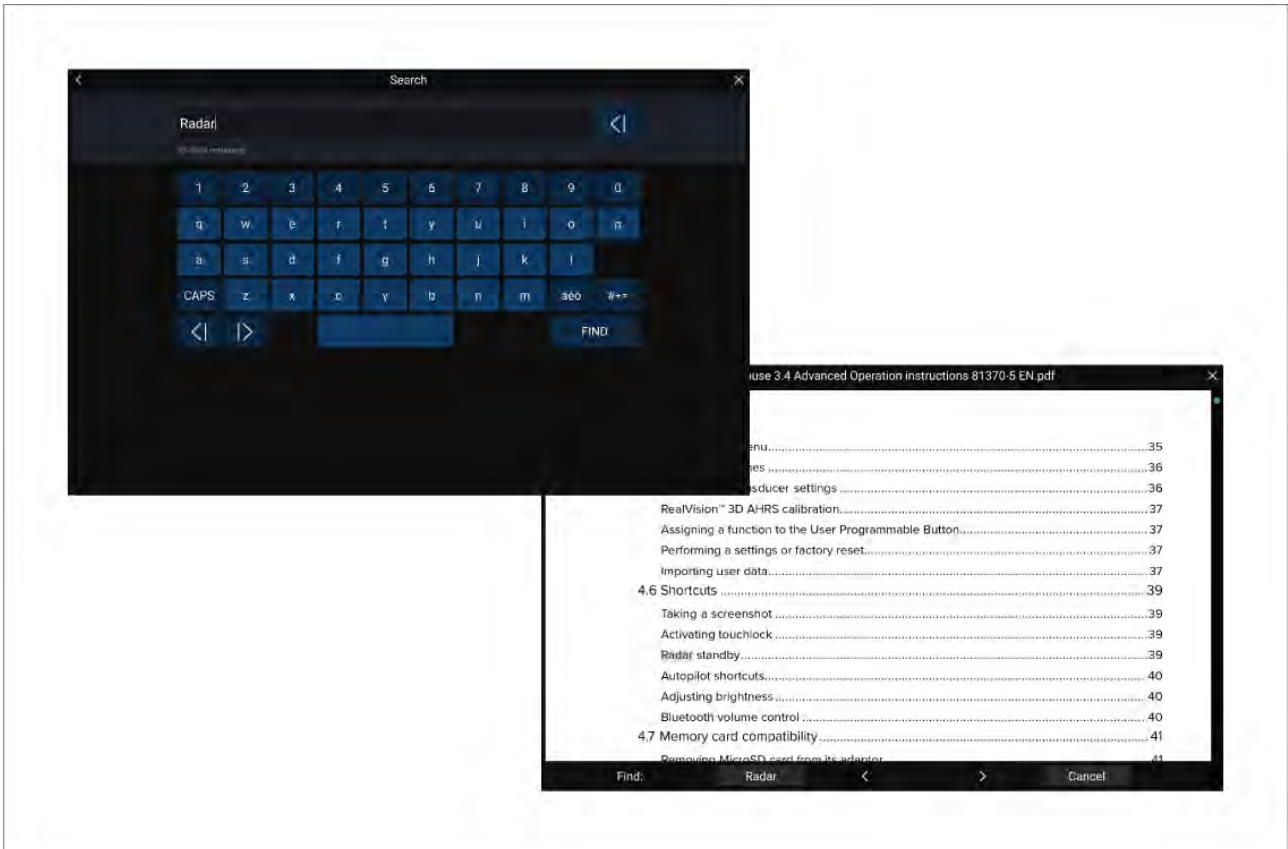

With the PDF displayed in the viewer:

1. Select **Find**.
2. Enter the word or search term.
3. Select **FIND**.

The document will scroll to the first occurrence of the searched term, which will be highlighted. Use the **Right arrow** and **Left arrow** controls to cycle to the previous or next occurrence of the search term. You can also search for another term by selecting **Find** and entering a new term, or you can cancel the find function by selecting **Cancel**.

Chapter 18: UAV (Unmanned Aerial Vehicle) app

Chapter contents

- 18.1 UAV disclaimer on page 312
- 18.2 UAV app overview on page 312
- 18.3 UAV pre-requisites on page 314
- 18.4 UAV precautions on page 316
- 18.5 Getting started on page 317
- 18.6 UAV app page on page 317
- 18.7 Opening the UAV app on page 318
- 18.8 Launching the UAV on page 320
- 18.9 Controlling the UAV in flight on page 320
- 18.10 Retrieving your UAV on page 321
- 18.11 Disconnect UAV remote controller from MFD on page 321
- 18.12 Fish on / Circle me mode on page 321
- 18.13 UAV Chart integration on page 322
- 18.14 UAV Emergency procedures on page 323

18.1 UAV disclaimer

The UAV app allows the FLIR multifunction display (“MFD”) to serve as an auxiliary controller for approved unmanned aerial vehicle (UAV) models. You are responsible for your own conduct while using the UAV and for any consequences thereof. You must use the UAV in accordance with all applicable legal regulations and safety recommendations of the UAV manufacturer. The primary controller should be readily accessible at all times while using the MFD as an auxiliary controller. FLIR accepts no liability for any damage, loss or injury caused by the UAV, whether caused by the use of the MFD or any other FLIR product. Particular attention must be paid to landing the UAV which must be done by the primary controller and not the MFD. By selecting continue, you confirm that you understand and accept these conditions.

18.2 UAV app overview

Axiom (Axiom™, Axiom™ Pro and Axiom™ XL) MFDs include the UAV (Unmanned Aerial Vehicle) app, which enables you to control a DJI Mavic Pro or Mavic Pro Platinum UAV using your MFD. The UAV app provides auxiliary remote controls, settings, video display and flight data for your connected UAV.

UAVs and MFDs have a one-to-one relationship, meaning that you can only control a UAV from the MFD that it is physically connected to. On an MFD network, each MFD can be connected to a different UAV, if required.

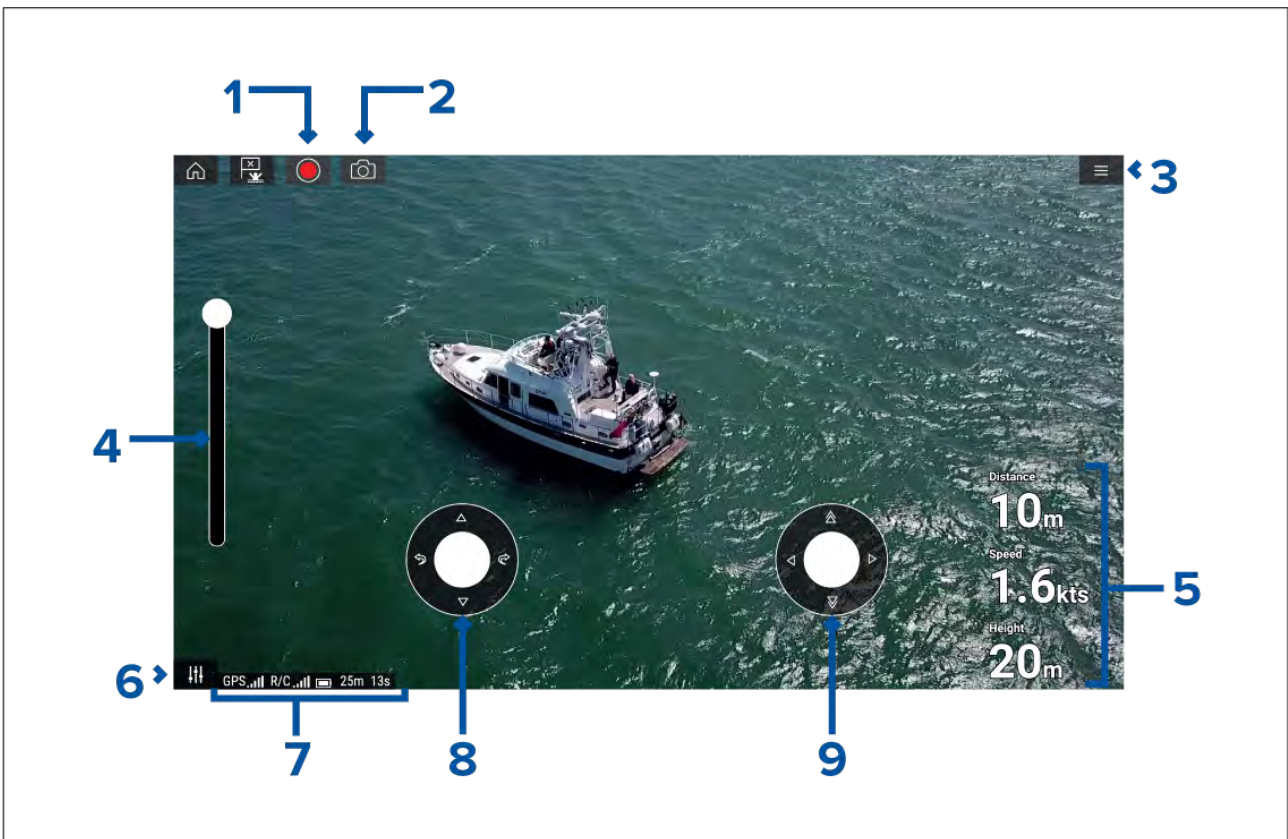

1	<p>Record Start recording your UAV’s video feed to a memory card inserted into the UAV’s memory card slot. While recording, the Record icon is replaced with a Stop icon and a time counter is displayed.</p>
2	<p>Take photo Take a screenshot of what is currently displayed in the UAV’s video feed. The image is saved to a memory card inserted into the UAV’s memory card slot.</p>
3	<p>Menu Opens the UAV app menu.</p>
4	<p>Gimbal pitch control Adjusts the pitch of the UAV’s camera gimbal, from pointing forwards (control at top of slider) to pointing straight down (control at bottom of slider).</p>

5	<p>Flight data Distance, Speed and Height data is displayed onscreen.</p> <div style="border: 1px solid black; padding: 5px;"> <p>Note: Displayed Flight data is specific to the UAV app and cannot be edited.</p> </div>
6	<p>Controls Provides access to the onscreen virtual joystick controls.</p>
7	<p>Status area The status area provides the:</p> <ul style="list-style-type: none"> • signal strength of the UAV's GNSS (GPS) position fix. • signal strength from remote controller to UAV. • battery charge state. • flight time remaining. • identification of restricted no fly zones.
8	<p>Virtual joystick Provides Up, Down, Turn left and Turn right controls.</p>
9	<p>Virtual joystick Provides Forward, Backward, Move left and Move right controls.</p>

<p>Note:</p> <ul style="list-style-type: none"> • The UAV app is not available on eS Series and gS Series MFDs. • On an Axiom XL MFD the UAV connects to the same connection as a remote card reader. Therefore, on a standalone Axiom XL MFD installation, electronic cartography, via a chart card, will NOT be available at the same time as a connection to your UAV. Only pre-loaded world basemaps will be available in the Chart application.

Compatible UAVs

Currently the UAVs listed below are supported:

- Mavic Pro by DJI
- Mavic Pro Platinum by DJI
- Mavic 2 Pro by DJI
- Mavic 2 Zoom by DJI

Connection to any other UAV is not approved and is performed at your own risk.

UAV sport mode

When your UAV is in Sport mode (S-Mode), control via your MFD is limited.

In Sport mode the following MFD controls are disabled **virtual joystick, Gimbal pitch control, Take off, Return to boat** and **Fish on / Circle me**.

UAV app settings menu

You should check and configure the settings listed in the Advanced settings menu before attempting to operate your UAV.

Advanced

Settings	Description
Initial height after take-off:	Specifies the height at which the UAV will hover once it has taken off.
Minimum safe height during UAV goto:	Specifies the minimum safe height of the UAV when performing a Goto.

Settings	Description
Action if remote control signal is lost:	If your UAV loses connection to the remote controller then you can select whether your UAV Hovers in its current location or performs a Return to boat .
Minimum height:	Specifies the minimum height of the UAV when performing a Return to boat.
Return distance:	Specifies the distance from your vessel the UAV will reach when performing a Return to boat.
Height:	Specifies the initial height of the UAV when performing a Fish on / Circle me.
Distance:	Specifies the initial distance from your vessel when performing a Fish on / Circle me.

Page settings

Settings	Description
Data Overlays	Enables configuration of Data overlays
Edit split ratio	Enables you to customize the position of the partitions in splitscreen app pages.

Data overlays in the UAV app are separate from the Flight data information.

18.3 UAV pre-requisites

Before you can use the MFD's UAV app with your UAV you must have:

- set up your UAV in accordance with the instructions provided with the device.
- registered your UAV using the applicable DJI app (e.g.: **DJI GO 4**) on your mobile device.
- gained experience of launching, flying and retrieving your UAV.
- removed the RC cable from the side of your UAV's remote controller.
- ensured the remote controller is not in Sport mode.
- Created a UAV app page icon on the MFD's Homescreen.

Removing the RC cable

The RC cable used for connecting the UAV's primary controller to a mobile device must be removed, before connecting the controller to your MFD.

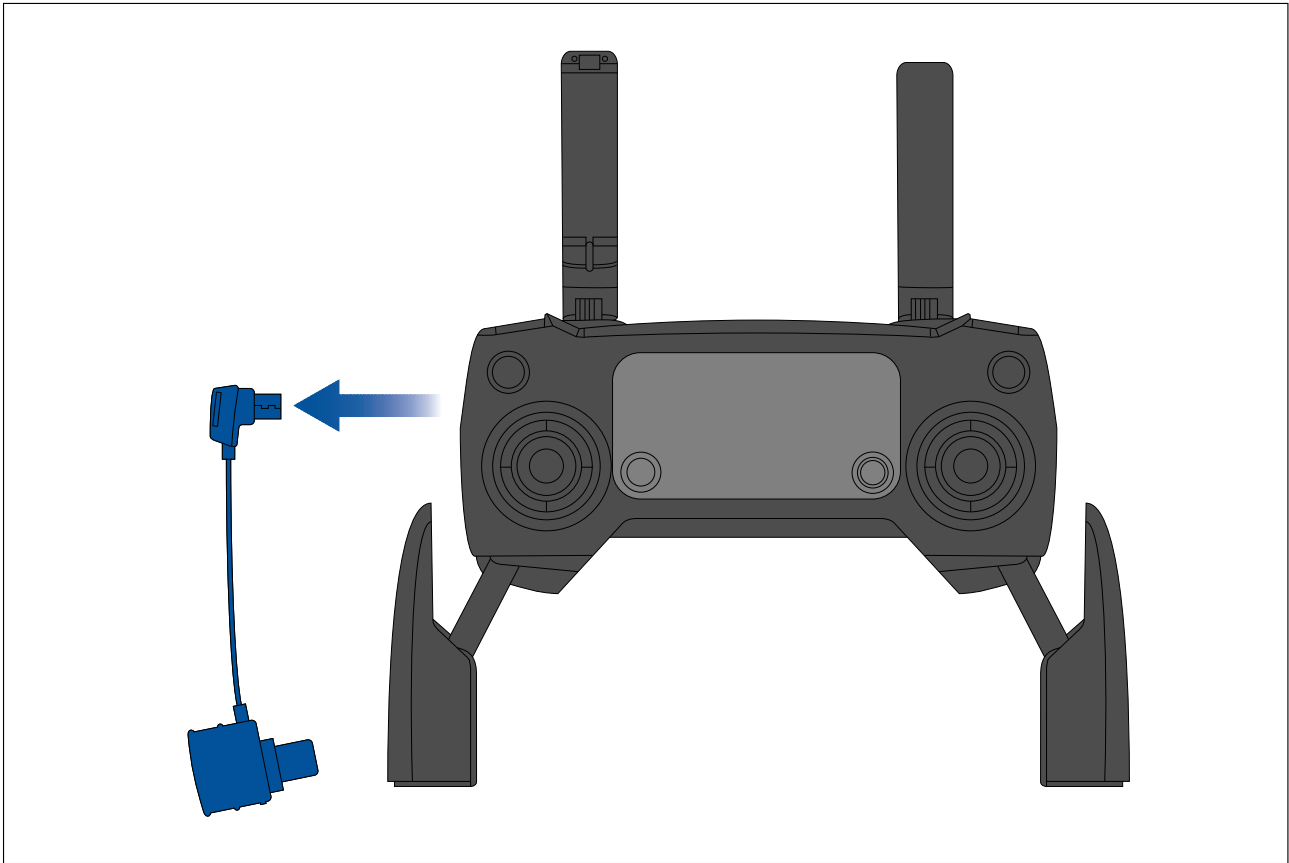

UAV controller connection

Your MFD's accessory connection must be connected to your UAV's primary remote controller using a USB "Micro B" to USB "A" cable.

Note:

- The UAV can NOT be connected to your MFD via the RCR-SDUSB. The card reader must be disconnected to enable connection to a UAV.
- The UAV can only be controlled by the MFD that the controller is connected to.

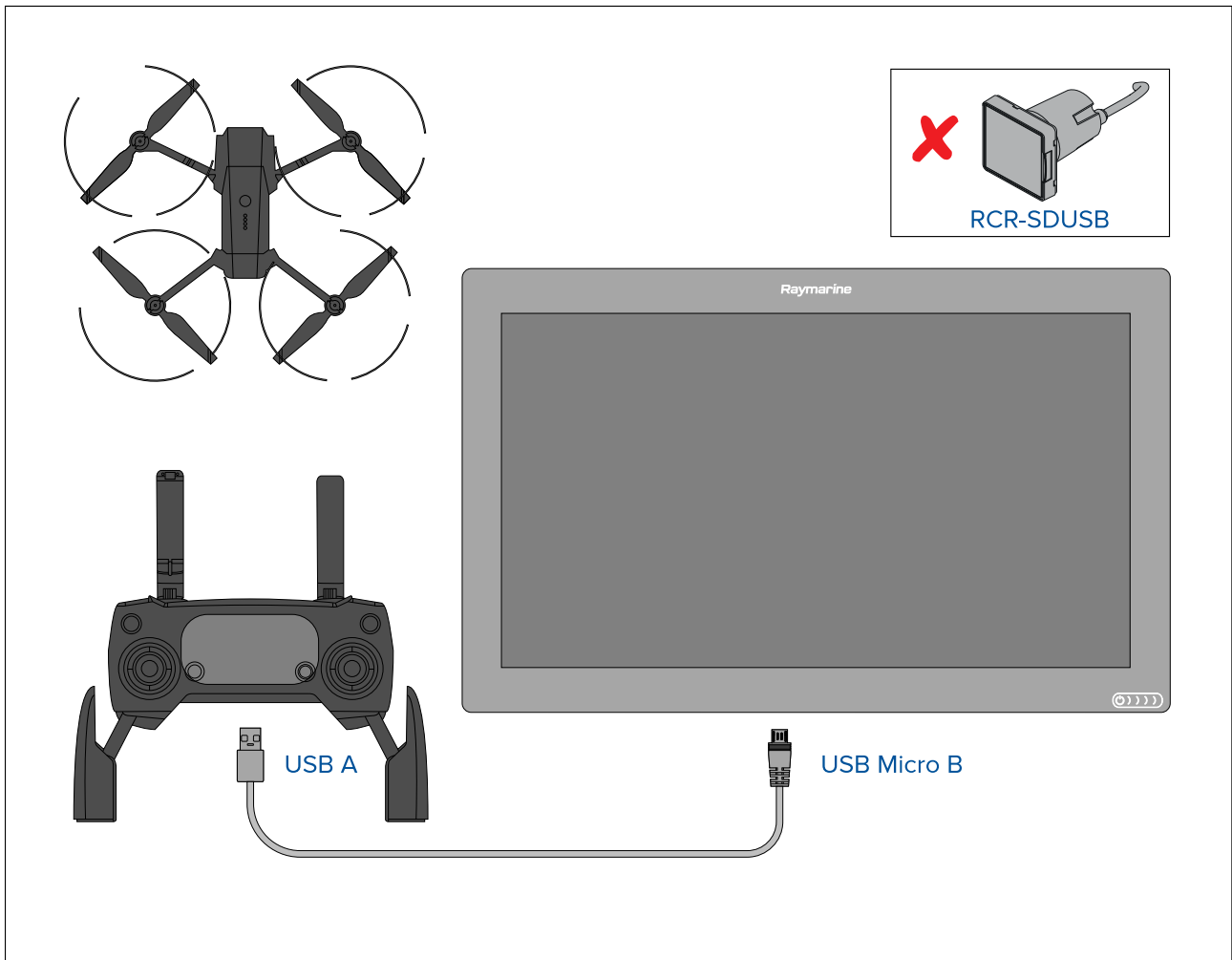

Important:

Ensure that the USB connection to your MFD is secure and protected against water ingress.

18.4 UAV precautions

Operating your UAV over water and launching and retrieving your UAV on a vessel can be a significantly different experience than when on land.

The following precautions should be followed:

- You will need to be an experienced, competent pilot as launching and retrieving the UAV on a vessel is more difficult due to confined space and vessel movement / drift.
- Only launch your UAV in calm wind and tide conditions. When attempting to launch or retrieve your UAV your vessel should be travelling at less than 1 knot and your captain should be ready at the helm to back down or maneuver the vessel to avoid accidental collisions
- Maintain awareness of your UAV's battery status, remaining flight time, distance from your vessel and Wind and Tide conditions. A UAV flying against the wind will consume battery power more rapidly than when flying downwind or in calm conditions. Always budget sufficient power reserves to ensure the safe return and retrieval of your UAV.
- Maintain a permanent watch of your UAV while in flight. The UAV pilot or competent observer must maintain awareness of surrounding air and marine traffic while the UAV is in flight. The pilot must remain ready to take control of the UAV and manually fly it to avoid interfering with other vessels or aircraft.
- While your UAV's controller is connected to your MFD it should be positioned so that it maintains line of sight with your airborne UAV. If the controller is not hand held then it must be secured to prevent it becoming disconnected from your MFD and to prevent unintentional button presses.

No-fly zones

It is illegal to fly your UAV in no-fly zones. No fly zones include:

- Airports
- Airfields
- Country borders
- Sensitive institutions

The Remote controller and the MFD will alert you that there is a no-fly zone. Your UAV will not enter the restricted airspace covered by a no-fly zone. You will also be unable to launch your UAV in restricted airspace. Please refer to the DJI app or the DJI website for more information on no-fly zones and their locations.

18.5 Getting started

Initial steps to get up and running with your UAV.

1. Using a **USB A to USB Micro B** cable, connect the Micro B end of the cable to the Accessory connection on the rear of your MFD.
2. Power on the MFD.
3. Obtain a GNSS (GPS) position fix on the MFD.
4. Open the UAV app.
5. Connect the MFD to the internet. (An internet connection is only required the first time you open the UAV app, after a Factory reset, or after an MFD software update).

Ensure that an internet connection is available on your MFD at the point of registration. If your vessel is likely to be out-of-range of cellular or satellite internet service at registration time, you will need to register the UAV before heading out on the water.

6. Wait for successful registration.
7. Power on the UAV's remote controller.
8. Power on the UAV.
9. Wait for the UAV to obtain a GNSS (GPS) position fix and for the "Ready to go" message to be displayed on the remote controller's screen.
10. Connect the USB A end of the USB cable to the relevant connection on the UAV's remote controller.

18.6 UAV app page

The UAV app is not displayed on the Homescreen by default. To open the UAV app you must first create a UAV app page icon on your MFD's Homescreen.

UAV control features are integrated with the Chart app; when creating a UAV app page it is recommended that you create a splitscreen Chart / UAV app page.

Follow the instructions detailed in the [5.4 Creating / Customizing an app page](#) section for information on creating an app page. Chart / UAV splitscreen app pages will be set to a 30/70 page split by default.

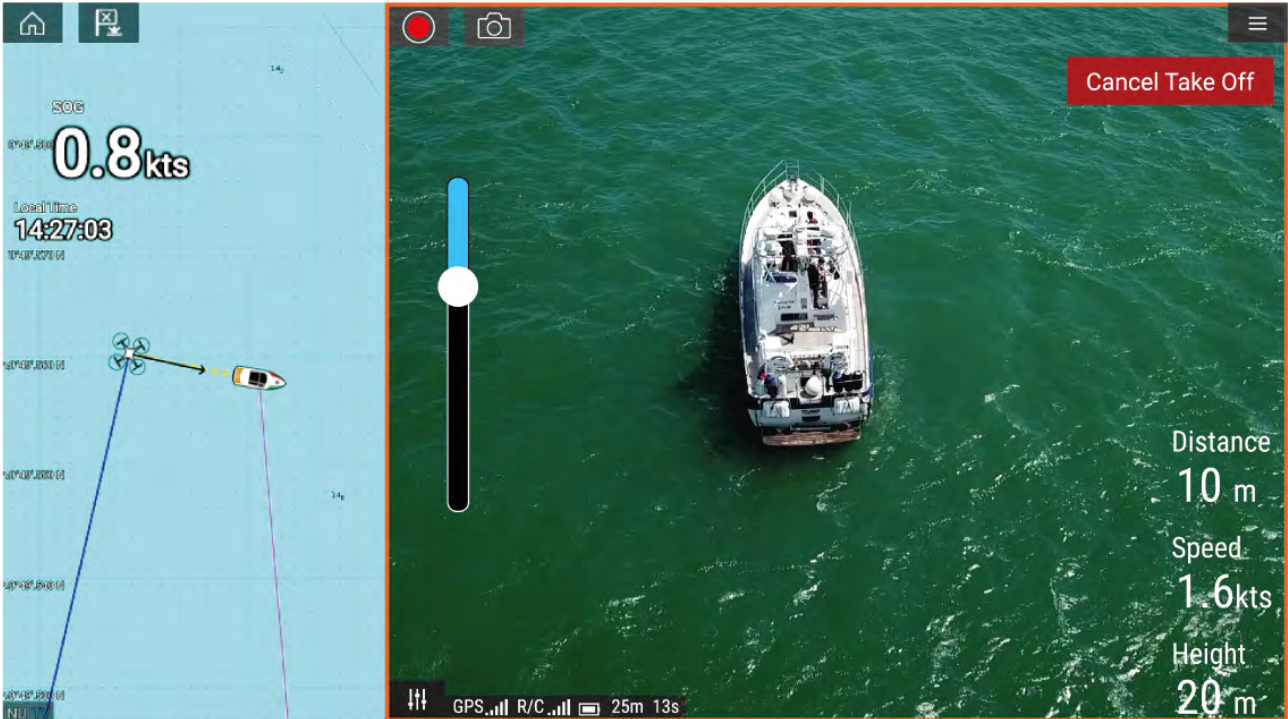

18.7 Opening the UAV app

The UAV app is opened from the Homescreen by selecting an app page icon that includes the UAV app.

The first time you open the UAV app and after each power cycle, a disclaimer is displayed. By selecting **Continue** you are agreeing to the terms of this disclaimer.

The UAV app will then open in 1 of 3 states:

No Wi-Fi connection



The first time you open the UAV app, after an MFD factory reset, or after you have updated your MFD's software, the UAV app must be registered using an internet connection on your MFD. Select **Wi-Fi Settings** to create an internet connection.



When registration is complete, if desired you can turn off your Wi-Fi connection by selecting **Wi-Fi Settings** and turning off your MFD's Wi-Fi. Selecting **OK** will close the info box keeping your Wi-Fi connection turned on.

Registration failed

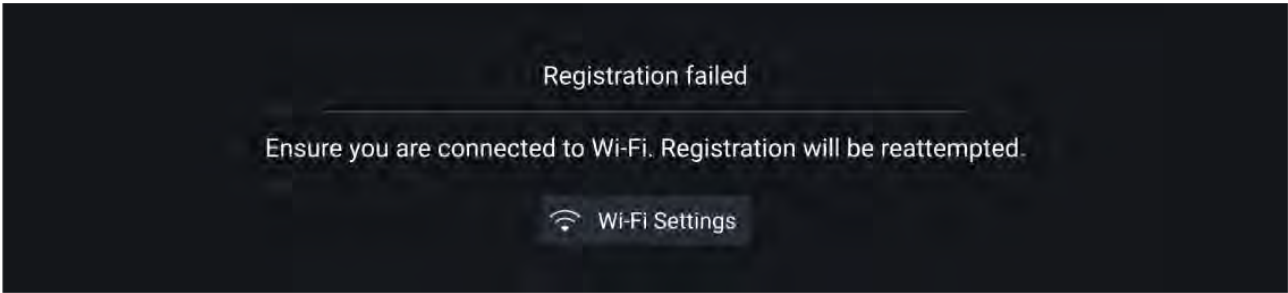

The registration failed notification is displayed if the DJI servers cannot be reached. Registration will be re-attempted automatically. If the failure persists, check your Wi-Fi and internet or try again later.

No connection detected



After successful registration, the 'No connection detected' notification is displayed. Connect the USB A end of your USB cable to the UAV's primary controller. Once a successful connection is established, the notification will be closed.

UAV app

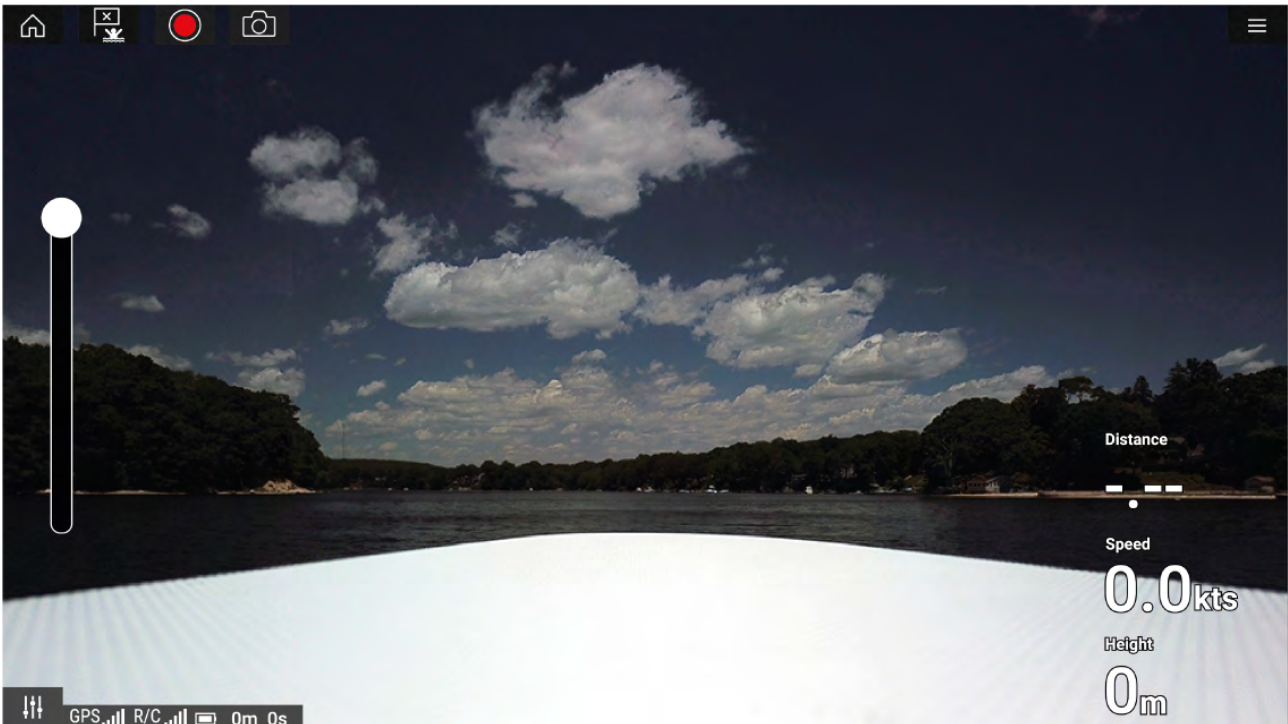

Once your UAV is correctly set up and connected to your MFD and your MFD's UAV app is registered successfully, the UAV's video feed is displayed and the app is ready to be used as an auxiliary controller for your UAV.

18.8 Launching the UAV

When it is safe to do so you can use the UAV app to launch your UAV.

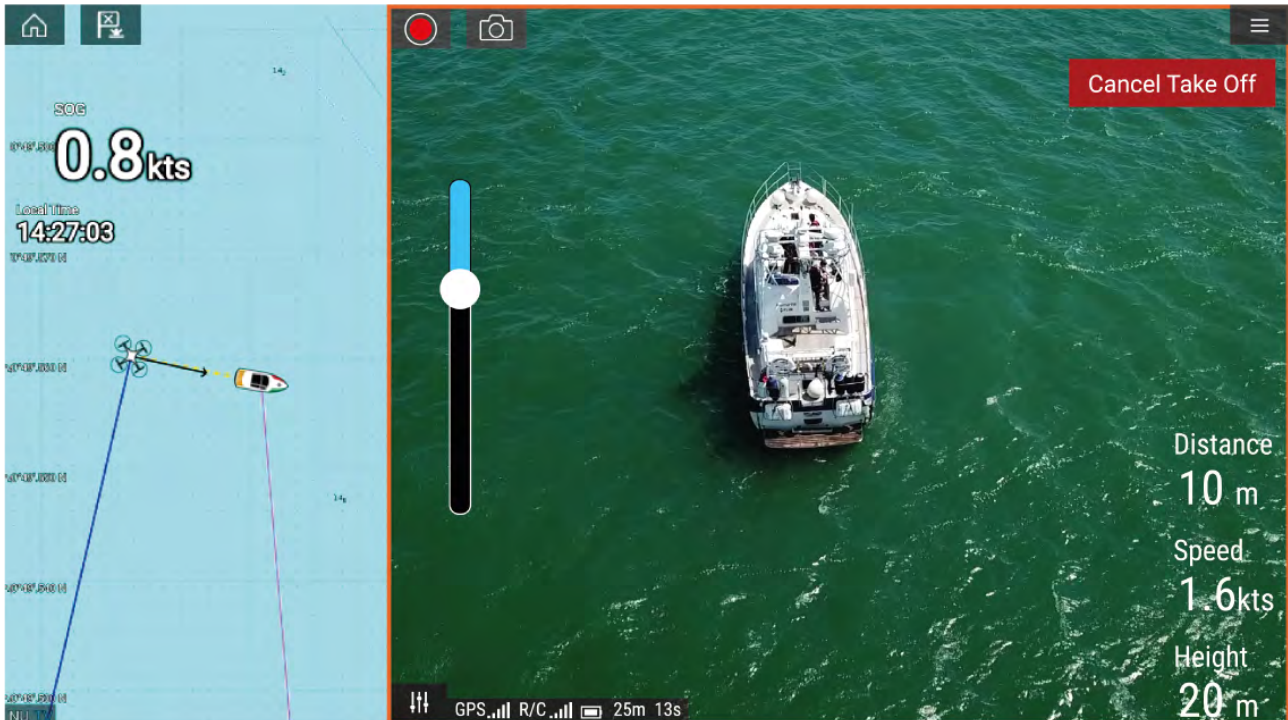

Prior to launch ensure that all necessary precautions have been taken to ensure no loss, damage or injury can occur.

1. Ensure your UAV is correctly connected and configured.
2. Ensure you have set an **Initial height after take-off**: in the appropriate Advanced settings menu: **Menu > Settings > Advanced > Initial height after take-off**:

Height needs to be sufficient so that your UAV will not collide with your vessel's sails, masts, rigging etc. or any other structure.

3. Place your UAV in an open space with sufficient room to launch unobstructed, taking into consideration the effects of wind direction and speed, tide direction and speed and the drift of your own vessel.
4. Select **Take off** from the UAV menu.
5. Select **Yes** to confirm take off.

The UAV will take off and lift to the height specified in step 2 above and hover.

The Take off can be cancelled at anytime by selecting the Red **Cancel Take Off** button. When **Cancel Take Off** is selected the UAV will stop and hover in its current position. If required, you can then use manual control to retrieve your UAV.

18.9 Controlling the UAV in flight

When in flight you can control the UAV using the onscreen virtual joysticks.

1. Select the **Controls** icon to display the **Virtual joysticks**.
2. The Virtual joysticks include controls for: **Up, Down, Turn left, Turn right, Forwards, Backwards, Move left and Move right**.
3. Use the **Gimbal pitch control** to move the UAV's camera to the required position.
4. If desired, use the **Record** and **Take photo** icons to record footage of your flight.

Note:

The Virtual joysticks take priority over your UAV's remote controller's joysticks, To use the remote controller's joysticks hide the Virtual joysticks by selecting the **Controls** icon.

18.10 Retrieving your UAV

To retrieve your UAV follow the instructions below:

1. Ensure that the **Minimum height** and **Return distance** settings are adequate for current conditions (Minimum height and Return distance can be adjusted from the Advanced settings menu: **Menu > Settings > Advanced**).
2. When you are ready to retrieve your UAV select the **Return to boat** option from the UAV app menu: **Menu > Return to boat**.

The UAV will return to your vessel's location within the specified Return distance and Minimum height, based on your MFD's current GNSS (GPS) position.

3. Once your UAV has reached the Return to boat position use the UAV's remote controller to manually retrieve your UAV safely.

Note:

The Return home manoeuvre can be cancelled at any time by selecting the Red, onscreen **Cancel return to boat** option. Once selected the UAV will stop and hover in its current position.

18.11 Disconnect UAV remote controller from MFD

When you have finished using the UAV app it is recommended that you disconnect the USB cable from the UAV's remote controller.

Before performing a MFD Factory reset, or software update, ensure that your UAV's remote controller is either powered off or disconnected from your MFD.

18.12 Fish on / Circle me mode

When Fish on / Circle me mode is activated your UAV will launch and circle your vessel, maintaining its camera's view on your vessel and recording the camera's video feed. Fish on / Circle me mode can also be initiated when your UAV is already in flight.

When your UAV is in Fish on / Circle me mode you should ensure your vessel speed does not exceed 10 knots or the UAV may not be able to keep up with your vessel. If your UAV cannot keep up slow your vessel speed.

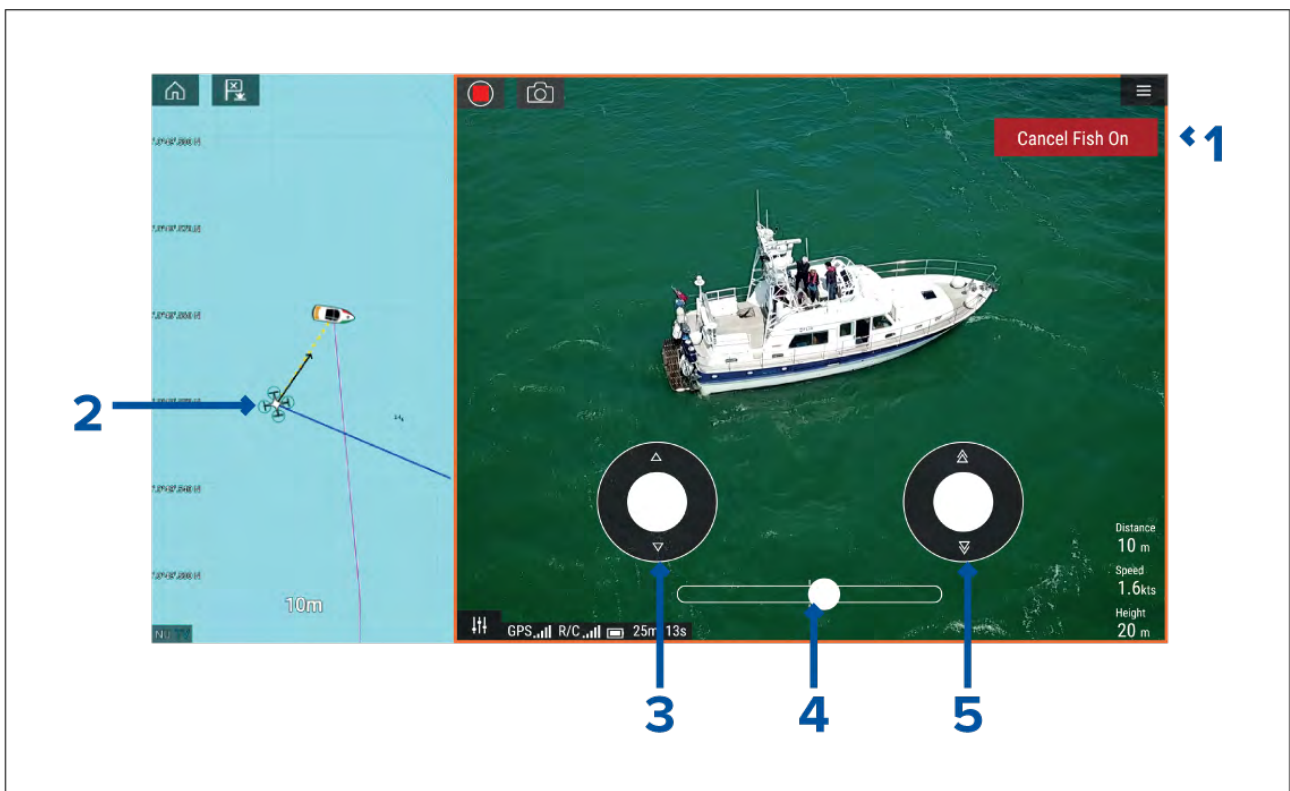

1	Cancel Fish On / Cancel Circle me Selecting Cancel Fish On / Cancel Circle me will stop Fish On / Circle me mode and the UAV will hover in its current location. If required you can manually stop recording by selecting the Stop icon.
2	UAV icon The UAV icon can be displayed in the Chart app. The icon includes a camera heading graphic, a Course Over Ground (COG) vector and a line linking your vessel icon to your UAV icon.
3	Virtual joystick In Fish On / Circle me mode the left virtual joystick provides Up and Down controls to adjust the UAV's distance from your vessel.
4	Rotation The Rotation slider control is used to adjust the UAV's direction of rotation and rotation speed. With the control on the slider center line the UAV will maintain position in relation to your vessel. Moving the slider right of the slider center line rotates the UAV counter-clockwise and moving the slider control to the left of the center line rotates the UAV clockwise. The farther left or right the slider control is set the faster the rotation speed will be.
5	Virtual joystick In Fish On / Circle me mode the right virtual joystick provides Forward and Backwards controls to adjust the UAV's height from your vessel.

Note:
During your initial MFD configuration the boating **Activity** you selected will determine whether the function is labelled **Fish on** or **Circle me**. If Fishing (freshwater), Fishing (saltwater) or Retail/demonstration is selected then the function is labelled **Fish on**, otherwise the function is labelled **Circle me**.

18.13 UAV Chart integration

When a compatible UAV with a GNSS (GPS) position fix is connected to your MFD, a UAV icon representing the position of the UAV is displayed in the Chart app.

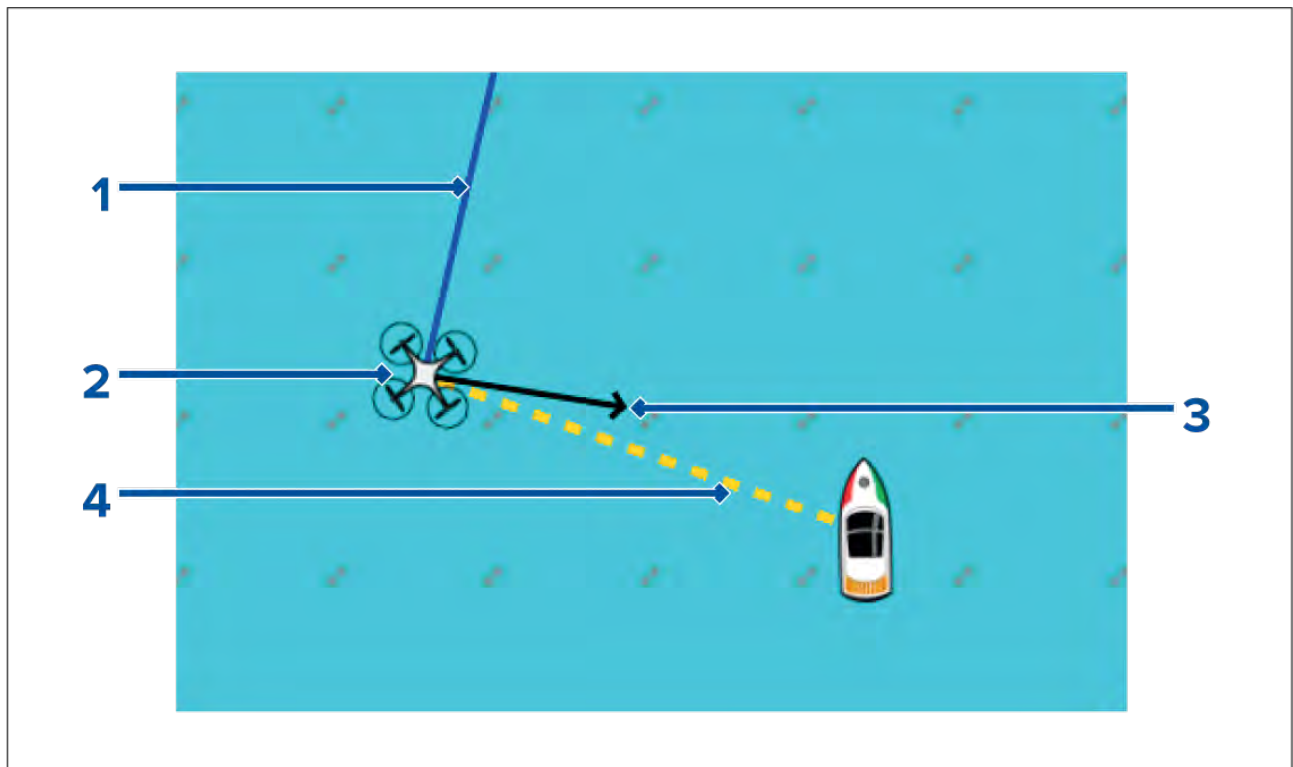

1	<p>UAV COG</p> <p>The direction of the Blue line indicates the UAV's current Course Over Ground (COG). The length of the line indicates the UAV's predicted position when the specified vector Reference period has passed.</p> <p>The Vector Reference period can be adjusted from the vessel icon's context menu.</p>
2	<p>UAV Icon</p> <p>Displayed when the UAV option is enabled in the Chart app settings, and your UAV has a GNSS (GPS) position fix.</p>
3	<p>Camera heading</p> <p>The Black Camera heading arrow is fixed to provide an indication of the direction the UAV's camera is pointing towards.</p>
4	<p>Line to vessel</p> <p>The Yellow dotted line represents the angle of the UAV's position relative to your vessel.</p>

Showing or hiding the UAV icon

The UAV icon is displayed by default in the Chart app. The icon can be hidden if required.

From the Chart app menu:

1. Select **Settings**.
2. Select the **Layers** tab.
3. Select the **UAV**: toggle switch.

Selecting the UAV toggle switch will make the UAV icon visible (on) or invisible (off).

Performing a UAV Goto

When your UAV is in flight you can select a location or object in the Chart app and perform a **UAV Goto** (your UAV will fly to the selected location or object and hover).

1. Select a location or object in the Chart app.
The Chart context menu is displayed.
2. Select **More**.
3. Select **UAV Goto**.

A UAV waypoint marker is placed to signify the UAV's destination and the UAV will fly to that location.

You can stop a UAV Goto at anytime by selecting the Red **Cancel UAV Goto** that is displayed onscreen in the UAV app, when a UAV Goto is active. Cancelling a UAV Goto will stop the Goto action and the UAV will hover in its current location.

A UAV Goto can be cancelled at any time by selecting **Stop UAV Goto** from the Chart context menu.

18.14 UAV Emergency procedures

The guidance below is intended to provide details of steps taken automatically by your UAV, and any manual intervention that may be required in certain situations.

Controller signal to UAV lost

In the event that your UAV loses its connection to the primary controller, the UAV will perform 1 of 2 actions, depending on your selection in the **Advanced** setting menu: **Menu > Settings > Advanced > Action if remote control signal lost**:

- **Hover** — The UAV will stop and hover in its current location. You should maneuver your vessel towards your UAV's position and attempt to re-establish control. When control is re-established it is recommended that you retrieve the UAV and inspect it immediately.
- **Return to boat** — The UAV will perform a Return to boat maneuver and hover at the **Return distance** and **Minimum height** specified in the Return to boat settings:
 - **Menu > Settings > Advanced > Minimum height**
 - **Menu > Settings > Advanced > Return distance**

If connection between the Remote controller and UAV is not re-established, your UAV will attempt to land.

Low battery warnings

Ensure while flying your UAV that you remain aware of the remaining flight time and distance from your vessel at all times. You must return your UAV to your vessel and safely retrieve it before a low battery warning occurs. The UAV app will mirror the UAV's primary controller battery state warnings.

- **Normal low battery level warning** — when the UAV reaches normal low battery level, in addition to the remote controller's audible and visual warnings a warning is also displayed on your MFD. You should immediately return the UAV to your vessel and retrieve.
- **Critical low battery warning** — when the UAV reaches critical low battery level, your UAV will automatically perform a **Return to boat** maneuver and attempt to land. It is not recommended that you allow your UAV to reach critical low battery while in flight, as it could result in damage or loss of your UAV.

Assuming manual control

The UAV pilot has the ability to take manual control of the UAV at any time. Manual control may be required for normal in-flight maneuvering or positioning, or in emergency situations. The methods of assuming manual control are as follows:

- Virtual joysticks will need to be hidden, using the **Controls** icon before control is returned to the Remote controller.
- Enabling Sport mode on the UAV's Remote controller at any time will override MFD controls. Fly with caution, as flight characteristics change in Sport mode.
- In an emergency, unplugging the USB cable from the Remote controller will override the MFD controls and immediately restore manual control to the Remote controller.

Chapter 19: LightHouse third-party apps

Chapter contents

- [19.1 LightHouse app launcher on page 326](#)
- [19.2 Lighthouse third-party apps - Preloaded on page 327](#)
- [19.3 Lighthouse third-party apps - Downloadable on page 328](#)
- [19.4 Installing Lighthouse third-party apps on page 328](#)
- [19.5 Internet connection on page 329](#)
- [19.6 Bluetooth speaker set up on page 330](#)

19.1 LightHouse app launcher

The app launcher provides a range of approved third-party apps on your MFD.

Important: The LightHouse app launcher and its associated third-party apps are not available on eS Series and gS Series MFDs.

Select **Apps** from the Homescreen to open the app launcher page.

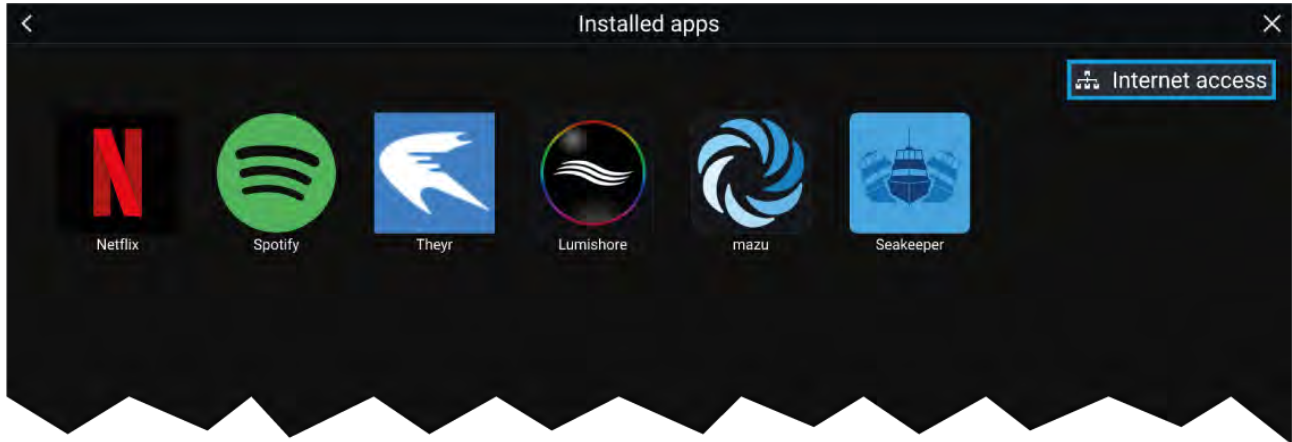

Selecting an app icon will launch the app. Selecting the Wi-Fi connection status button, located on the top right of the screen, will open the Wi-Fi connection settings to enable you to connect to the internet over Wi-Fi.

Apps may run in the background, enabling you to use your MFD as usual whilst, for instance, listening to music.

MFD alarms will be displayed and sounded as normal whilst using LightHouse third-party apps. When paired with a Bluetooth speaker, alarms will also be sounded through the speaker.

Bluetooth speaker volume can be controlled from the Shortcuts page or from the Status bar area on the Homescreen.

Note:

- Some app features or access to the apps may require your MFD to have an internet connection.
- If you use a wireless connection to a Quantum Radar, the Radar should be put in Standby before connecting your MFD to the internet.
- Some apps may also require an audio output. You can pair a Bluetooth speaker with your MFD to enable audio output.
- Raymarine does not provide support for third-party apps or any related third-party hardware. Please refer to the relevant third party app developer for assistance and troubleshooting.

LightHouse third-party apps

LightHouse™ third-party apps are apps that have been developed by third parties and approved for use on the LightHouse™ 3 operating system.

Note:

Raymarine does not provide support for third-party apps or any related third-party hardware. Please refer to the relevant third party app developer for assistance and troubleshooting.







Raymarine does not warrant that LightHouse™ third-party apps are error-free, and will not be held liable for damages or injuries caused by improper or inappropriate use of these apps.

 **Warning: Maintain a permanent watch**

Do NOT navigate whilst distracted by entertainment apps. Failure to maintain a permanent watch puts yourself, your vessel and others at serious risk of harm.





19.2 Lighthouse third-party apps - Preloaded

Below is a list of Lighthouse third-party apps preloaded to your MFD and details for each.

	<p>Netflix</p> <ul style="list-style-type: none"> • Requires Lighthouse Software version 3.4 or later. • Requires internet connection. • Log in using your existing subscription or join free for a month directly from the app. • Refer to Netflix (www.netflix.com) for details.
	<p>Spotify</p> <ul style="list-style-type: none"> • Requires Lighthouse Software version 3.4 or later. • Requires internet connection. • Log in using your existing subscription or join free directly from the app. • Refer to Spotify (www.spotify.com) for details.
	<p>Lumishore</p> <ul style="list-style-type: none"> • Requires Lighthouse Software version 3.5 or later. • Requires compatible Lumishore hardware to be powered on and connected to the same network as your MFD. • Refer to Lumishore (www.lumishore.com) for details.
	<p>Mazu</p> <ul style="list-style-type: none"> • Requires Lighthouse Software version 3.5 or later. • Requires compatible Mazu-marine hardware to be powered on and connected to the same network as your MFD. • Refer to Mazu (www.mazu-marine.com) for details.
	<p>Seakeeper</p> <ul style="list-style-type: none"> • Requires Lighthouse Software version 3.7 or later. • Requires compatible Seakeeper hardware to be powered on and connected to the same network as your MFD. • Refer to Seakeeper (www.seakeeper.com) for details.
	<p>Shadow-Caster</p> <ul style="list-style-type: none"> • Requires Lighthouse Software version 3.10 or later. • Requires compatible Shadow-Caster hardware to be powered on and connected to the same network as your MFD. • Refer to Shadow-Caster (https://shadow-caster.com/) for details.
	<p>Victron Energy</p> <ul style="list-style-type: none"> • Requires Lighthouse Software version 3.11 or later. • Requires compatible Victron Energy hardware to be powered on and connected to the same network as your MFD. • Refer to Victron Energy (https://www.victronenergy.com/marine-mfd-gx-integration) for details.

19.3 Lighthouse third-party apps - Downloadable

Below is a list of Lighthouse third-party apps that can be downloaded to your MFD and details for each.

<p>Note:</p> <ul style="list-style-type: none"> Lighthouse third-party apps can be downloaded from: http://www.raymarine.com/multifunction-displays/lighthouse3/lighthouse-apps/ For more information on installing Lighthouse third-party apps refer to: p.328 – Installing Lighthouse third-party apps 	
	<p>GRIBview</p> <ul style="list-style-type: none"> Requires Lighthouse Software version 3.4 or later. Requires internet connection to download weather data directly to your MFD. Weather data can also be downloaded and placed on external storage for viewing at a later time (when your MFD has no internet connection available). Log in using your existing Theyr subscription or register for free account directly from the app. <div style="border: 1px solid black; padding: 5px; margin: 5px 0;"> <p>Note: It is not currently possible to log in to the app using an existing Raymarine LightHouse 2 subscription to Theyr weather.</p> </div> <ul style="list-style-type: none"> Refer to Theyr (www.theyr.com) for details.
	<p>Buoyweather</p> <ul style="list-style-type: none"> Requires Lighthouse Software version 3.10 or later. Requires internet connection. Log in using your existing subscription or join directly from the app. Refer to Buoyweather (http://www.buoyweather.com/) for details.
	<p>PredictWind</p> <ul style="list-style-type: none"> Requires Lighthouse Software version 3.10 or later. Requires internet connection. Log in using your existing subscription or join directly from the app. Refer to PredictWind (https://www.predictwind.com/) for details.
	<p>Offshore</p> <ul style="list-style-type: none"> Requires Lighthouse Software version 3.10 or later. Requires internet connection to download weather predictions. App can still display predictions if internet connectivity is lost. Weather predictions will update when internet connection is restored. Log in using your existing subscription or join directly from the app. Refer to PredictWind (https://www.predictwind.com/) for details.

19.4 Installing Lighthouse third-party apps

Additional Lighthouse third-party apps can be installed on your MFD via an SD card or USB.

Note: Only APK-approved Lighthouse third-party apps can be installed on your MFD. APK-approved Lighthouse third-party apps can be downloaded from: <http://www.raymarine.co.uk/lighthouse-apps/>

To install Lighthouse third-party apps:

1. Insert SD card or USB device into your MFD or external card reader.
2. From the **App Launcher** page, select **Install from SD / USB**.

3. Select the SD card or USB device that contains the third-party app file.
4. Select the APK file and it will automatically install on your MFD.
5. The app will be located on the **App Launcher** page.

Note: You can uninstall Lighthouse third-party apps from your MFD by long pressing them and selecting **uninstall**.

19.5 Internet connection

Connecting to the internet

From the Homescreen:

1. Select **Apps**.
The app launcher is displayed.
2. Select the Wi-Fi connection status button, located on the top right of the app launcher page.
The Wi-Fi settings page is displayed and will scan for available networks.
3. Select the relevant connection.
4. Enter the password for the network and select **Connect**.
Your MFD will now connect to the chosen network.
5. Select the **Back** triangle symbol or the **Home** Circle symbol at the bottom of the screen.
You can now use LightHouse™ apps that require an internet connection.

Wi-Fi settings

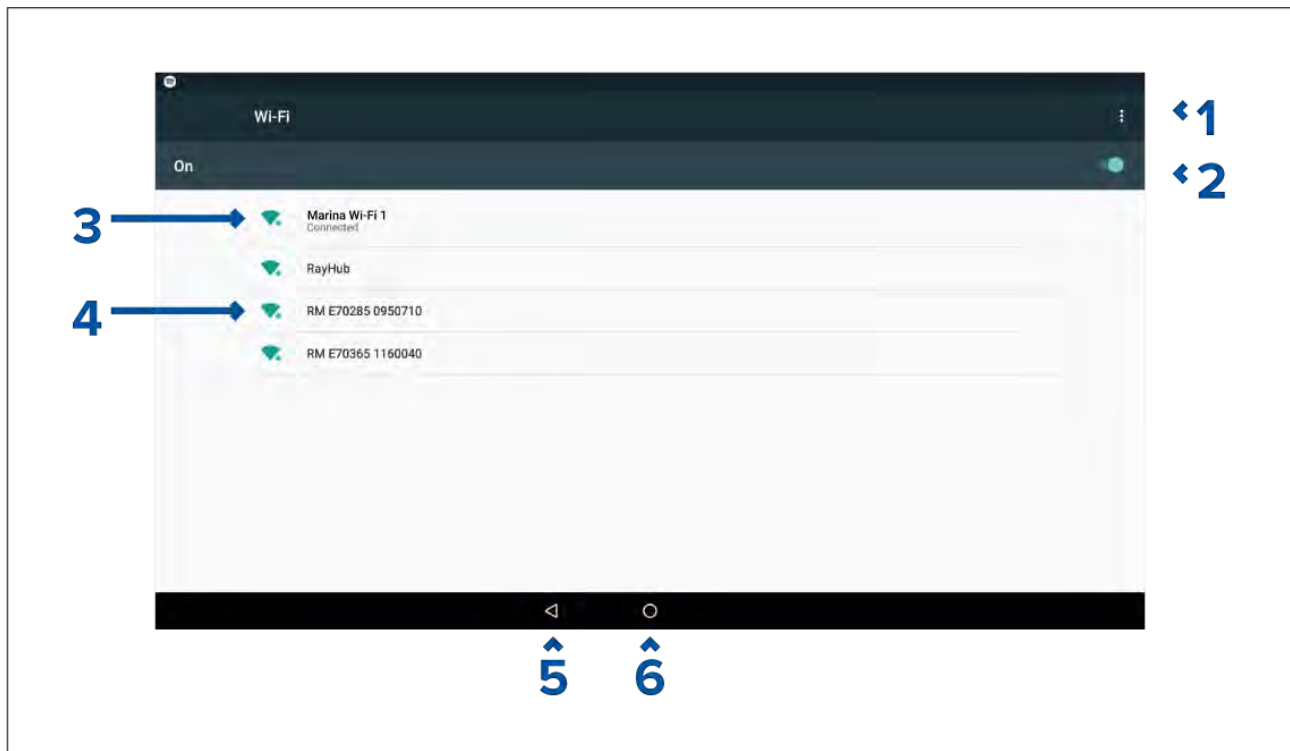

1. Wi-Fi options — Provides the following options:
 - Add network — Manually add a network.
 - Saved networks — View a list of all saved networks.
 - Refresh — Rescan available networks.
 - Advanced — View advanced network settings.
2. Enable/Disable Wi-Fi.
3. Connected access point.
4. Available access points.
5. Back button.

6. Home button

19.6 Bluetooth speaker set up

Enabling and disabling Bluetooth

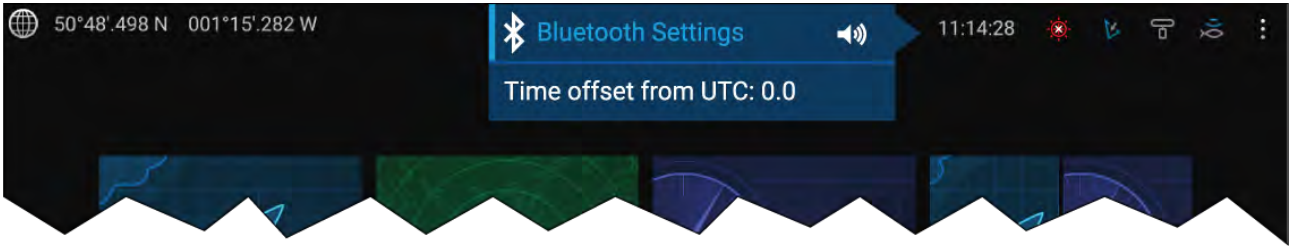

1. Select the Status bar area located in the top right of the screen.
2. Select **Bluetooth Settings**.
3. Select the Toggle switch on the right of the Bluetooth settings page to enable Bluetooth.

Alternatively the Bluetooth settings page can be accessed from the This display settings tab:
Homescreen > Settings > This display > Bluetooth > Bluetooth settings.

Bluetooth Settings

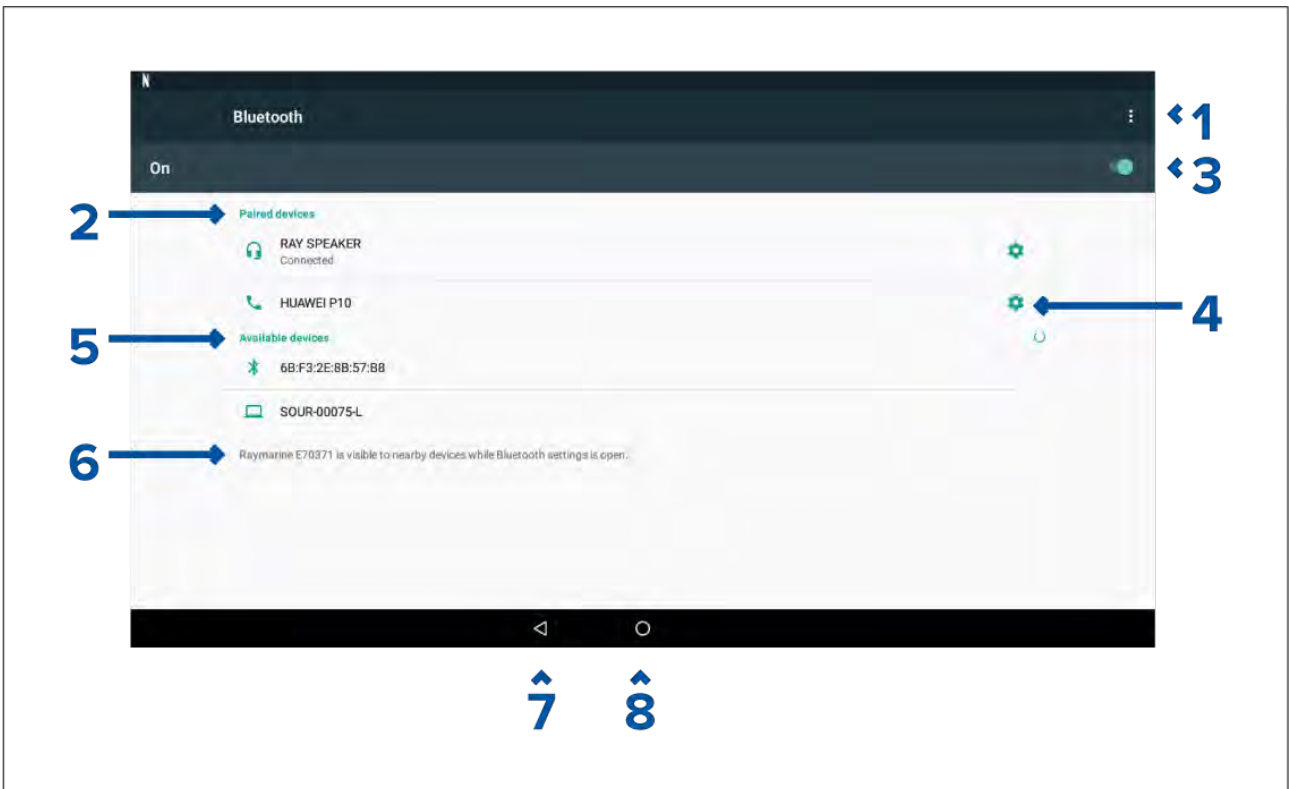

1. Bluetooth options — Provides the following options:
 - Refresh — Selecting refreshes the list of available devices.
 - Rename this device — Allows you to rename the Bluetooth name your MFD uses.
 - Show file received — Not used as your MFD cannot receive files over Bluetooth.
2. Paired devices — List of devices paired with your ~MFD.
3. Enable/Disable Bluetooth.
4. Paired device settings — Allows you to rename the paired device or forget the device.
5. Available devices — List of available Bluetooth devices.
6. MFD Bluetooth name.
7. Back button.

8. Home button.

Pairing a Bluetooth speaker

Before attempting to pair with a Bluetooth speaker, ensure that the speaker is switched on and discoverable.

With your MFD's Bluetooth enabled:

1. From the Bluetooth settings page, select the relevant device from the **Available devices** list.
2. If requested, confirm the bluetooth pairing code.

If pairing is successful the speaker will appear in the **Paired devices** list and display the **Connected** message.

Bluetooth volume control

When your MFD is connected to a Bluetooth speaker, controls will be available to adjust speaker volume.

Homescreen



From the Homescreen select the Status area and then select the Speaker symbol to display the Bluetooth volume control for LightHouse™ app and MFD alarms.

Shortcuts page

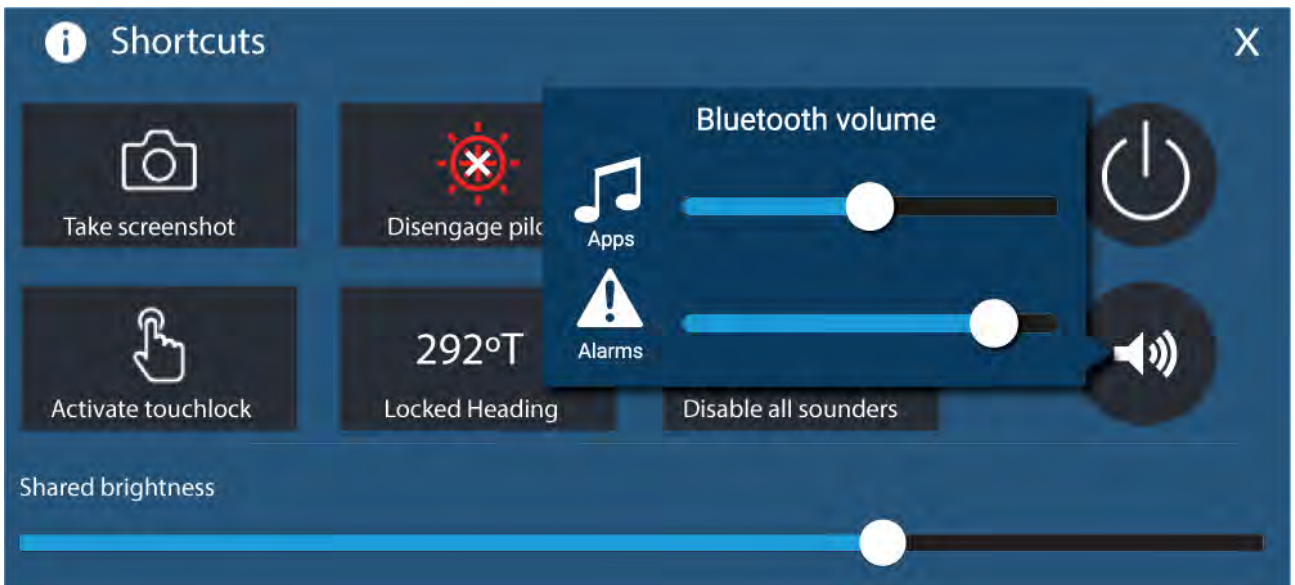

Press or swipe the **Power** button to display the Shortcuts page and then select the speaker symbol to display the Bluetooth volume control for LightHouse™ apps and MFD alarms.

Chapter 20: Mobile app support

Chapter contents

- 20.1 Raymarine mobile apps on page 334
- 20.2 Connect to Wi-Fi - Android on page 334
- 20.3 Connect to Wi-Fi - iOS on page 335
- 20.4 Controlling your MFD using RayControl on page 335
- 20.5 Controlling your MFD using RayRemote on page 336
- 20.6 Viewing your MFD screen using RayView on page 337
- 20.7 Navionics plotter sync on page 337
- 20.8 Fishidy sync on page 337

20.1 Raymarine mobile apps

Please check the relevant app store for Raymarine mobile apps.

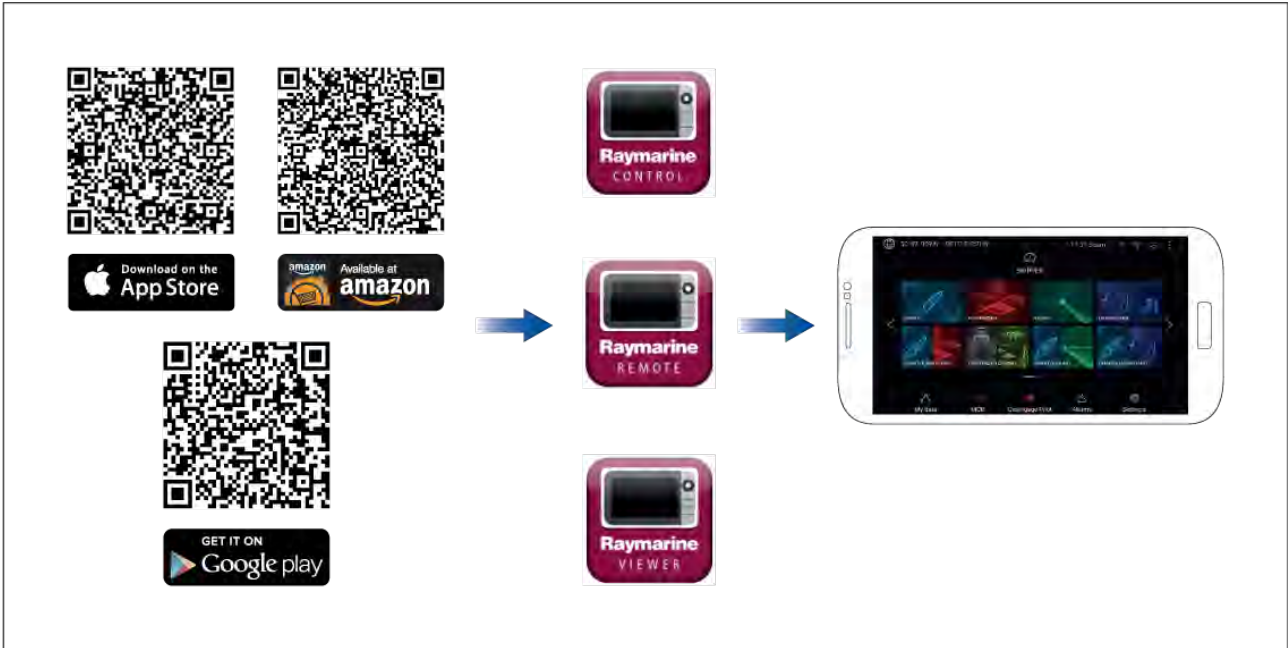

Note: When updating your MFD software ensure that you check for updates to your mobile apps.

20.2 Connect to Wi-Fi - Android

Connect your Android device to the MFD Wi-Fi.

Open your Android device's Wi-Fi from the top drop down menu or via **Settings**.

Homescreen > Settings > Connections > Wi-Fi

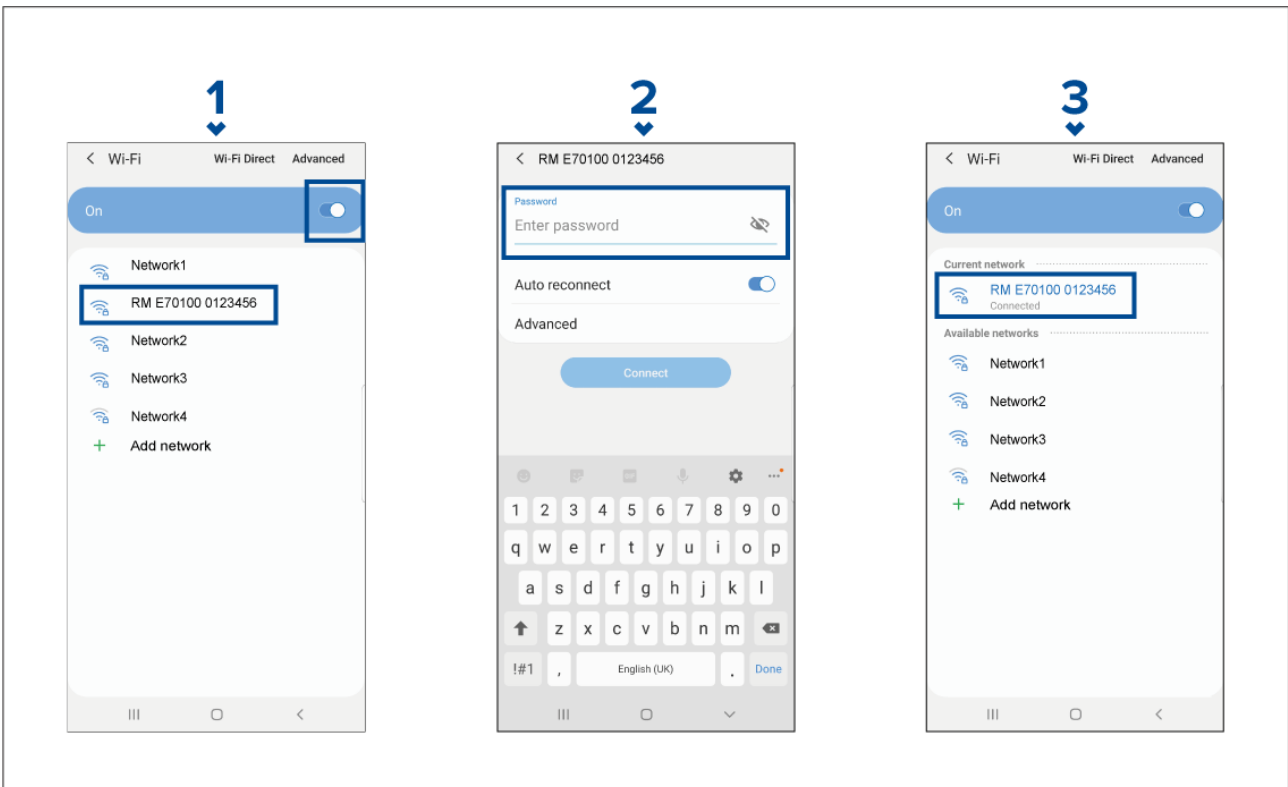

1. Enable Wi-Fi by setting the toggle to on (blue) and select your MFD from the available networks.
2. Enter your MFD's Wi-Fi password and select connect.

Make sure the password you enter is case sensitive.

3. When your Android device is connected to your MFD's Wi-Fi it will display connected under the MFD's name.

For troubleshooting advice refer to [p.352 – Wi-Fi troubleshooting](#)

20.3 Connect to Wi-Fi - iOS

Connect your iOS device to the MFD Wi-Fi.

Open your iOS device's Wi-Fi from the top drop down menu or via **Settings**.

Homescreen > Settings > Wi-Fi

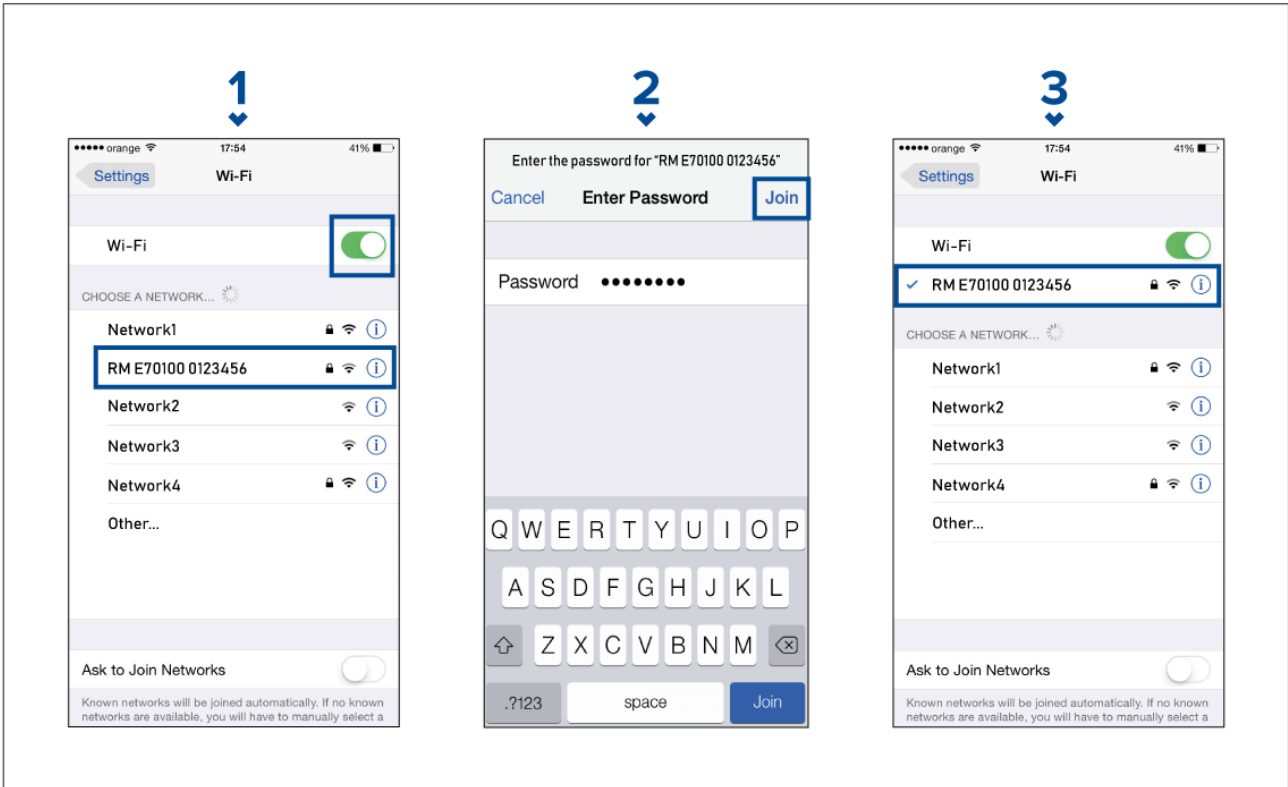

1. Enable Wi-Fi by setting the toggle to on (green) and select your MFD from the available networks.
2. Enter your MFD's Wi-Fi password and select join.

Make sure the password you enter is case sensitive.

3. When your iOS device is connected to your MFD's Wi-Fi it will display a tick next to the MFD's name.

For troubleshooting advice refer to [p.352 – Wi-Fi troubleshooting](#)

20.4 Controlling your MFD using RayControl

The RayControl app allows you to remotely view and control your MFD from your mobile device.

1. Download and install RayControl from your app store.
2. Ensure your mobile device is connected to your MFD's Wi-Fi.
3. Open the RayControl app.
4. Control your MFD using your mobile device's touchscreen in the same way you would interact with the MFD's touchscreen.
5. You can also use a representation of an Axiom Pro's or RMK remote's physical buttons by sliding the controls sidebar out from the right of the screen or on smaller devices selecting **Remote Control**.

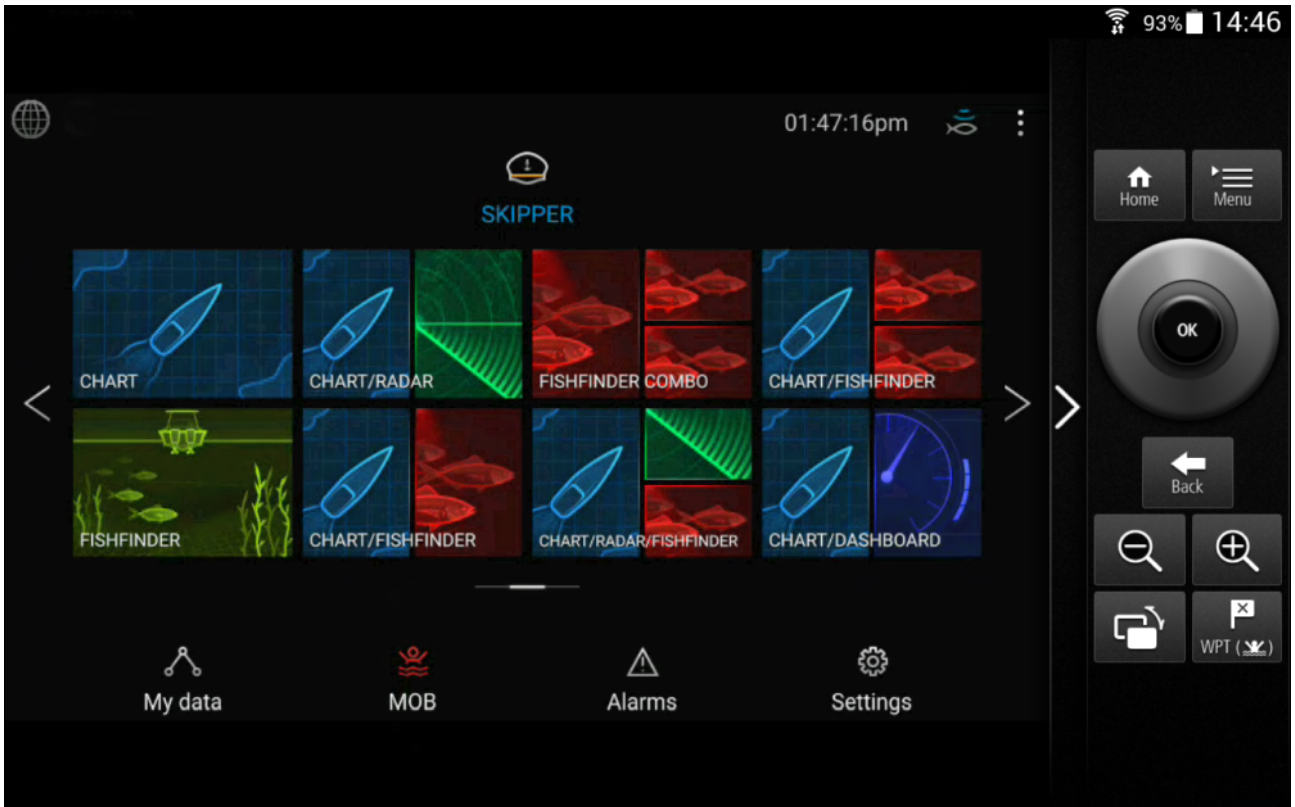

20.5 Controlling your MFD using RayRemote

The RayRemote app allows you to remotely control your MFD from your mobile device.



1. Download and install RayRemote from your app store.
2. Ensure your mobile device is connected to your MFD's Wi-Fi.
3. Open the RayRemote app.
4. Control your MFD on your mobile device using the on-screen equivalents of the physical buttons found on the Axiom Pro MFD or RMK remote keypad.

20.6 Viewing your MFD screen using RayView

The RayView app allows you to remotely view your MFD from your mobile device.

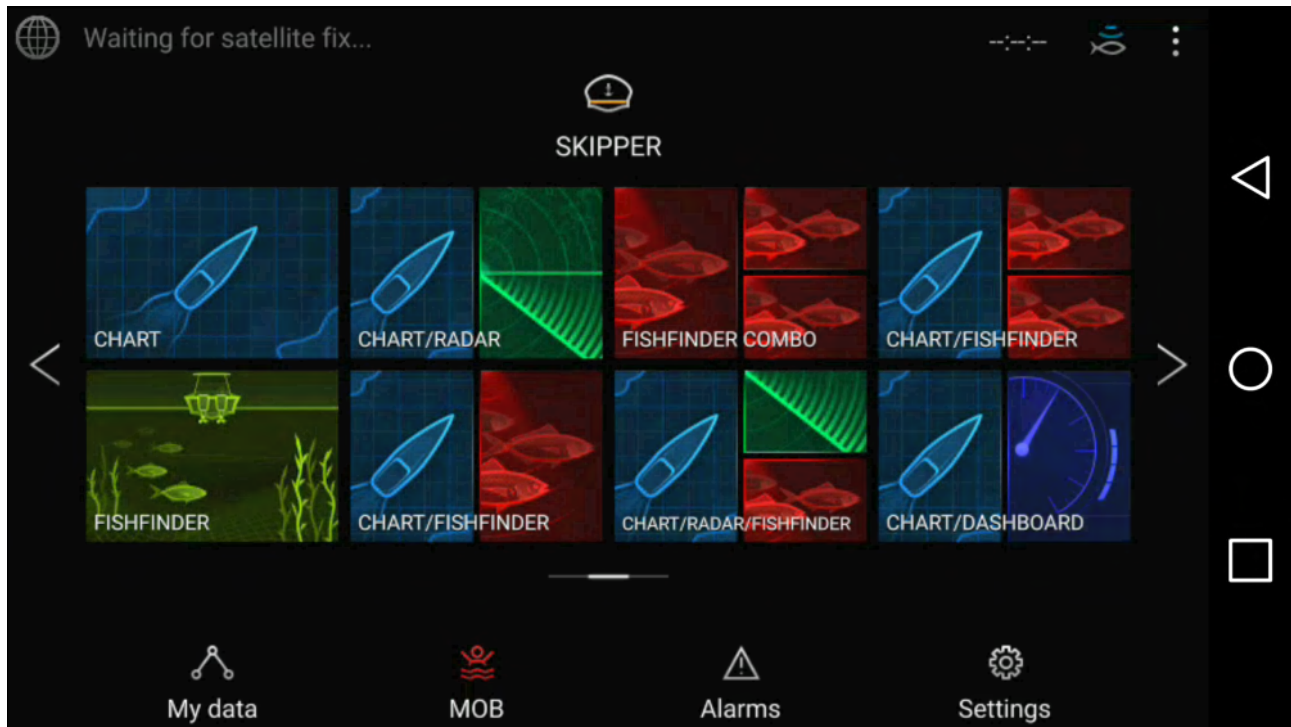

1. Download and install RayView from your app store.
2. Ensure your mobile device is connected to your MFD's Wi-Fi.
3. Open the RayView app.
4. Your mobile device's screen will now mirror your MFD's screen.

20.7 Navionics plotter sync

You can use the Navionics boating mobile app to:

- transfer waypoints and routes between your MFD and mobile device.
- update, activate and renew your Navionics cartography

20.8 Fishidy sync

You can synchronize Fishidy Spots and Waypoints between the Fishidy app and your MFD's Chart app.

Note:

Fishidy sync requires:

- Fishidy software version 6.1.0 or later.
- Lighthouse software version 3.11 or later.

Note:

Fishidy is currently available in:

- North America

Additional regions will become available in future Fishidy updates.



Enable sync

After connecting your mobile device to your MFD's Wi-Fi, you can begin syncing waypoints and Fishidy spots with the Fishidy app.

1. From the Fishidy app select **More**.
2. Select **Raymarine Sync**.
3. Select **Enable Sync** to begin synchronization between your Fishidy app and MFD.

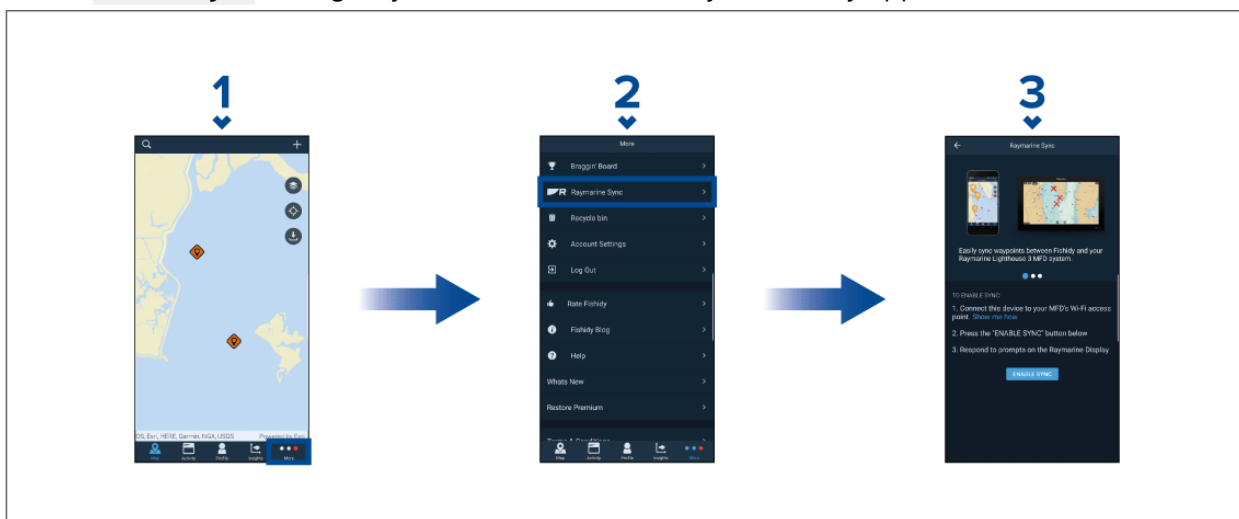

4. When prompted by your MFD, select **Yes** to confirm sync.

If you select **No**, sync will be cancelled and will need to be restarted.

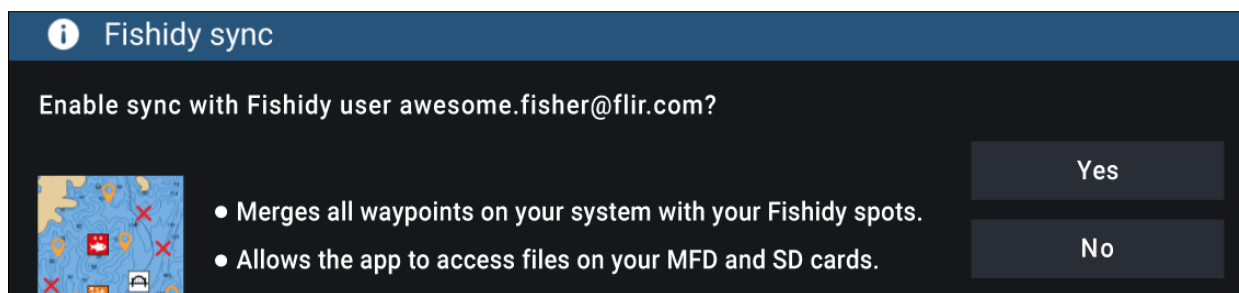

Once enabled, data will automatically sync in real-time across both devices via Wi-Fi.

Note:

- Fishidy Spots and Waypoints will be shared and can be interacted with from both devices.
- Your private waypoints remain private, whether viewing on Fishidy or your Raymarine MFD system.
- If you edit a Fishidy Spot or Waypoint on either device when sync is disabled (e.g. editing the name), re-enabling sync might place the item in the Fishidy **Recycle Bin**. In this scenario, the data can be restored from the recycling bin in the Fishidy app.
- Attempting to sync a new Fishidy account to your MFD while it is already synced with another account will prompt you to end sync with the first account. Ending sync with the first account and syncing the second account replaces any existing Fishidy Spots and Waypoints.

Disable sync

You can disable Fishidy sync from the Fishidy app or your MFD.

1. **Fishidy app**
 - i. Access the **Raymarine Sync** menu and select **Disable Sync**.
 - ii. **More > Raymarine Sync > Disable Sync**
2. **MFD**
 - i. Access the **My Data** page, select **Mobile sync** and select **Disable sync**.
 - ii. **Homescreen > My Data > Mobile sync > Disable sync**

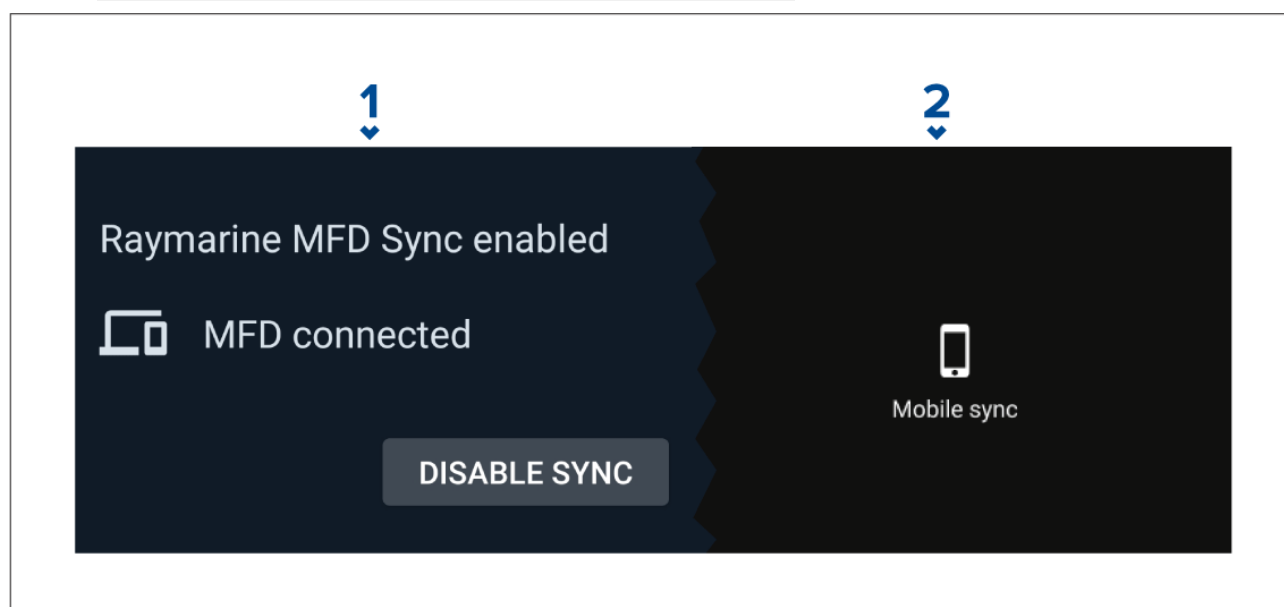

Chapter 21: Troubleshooting

Chapter contents

- 21.1 Troubleshooting on page 342
- 21.2 Diagnostic product information on page 342
- 21.3 Power up troubleshooting on page 343
- 21.4 Radar troubleshooting on page 345
- 21.5 GNSS (GPS) troubleshooting on page 346
- 21.6 Sonar troubleshooting on page 346
- 21.7 Camera troubleshooting on page 349
- 21.8 Augmented Reality (AR) Troubleshooting on page 351
- 21.9 Wi-Fi troubleshooting on page 352
- 21.10 Wireless display troubleshooting on page 354
- 21.11 Data troubleshooting on page 355
- 21.12 Touchscreen troubleshooting on page 355

21.1 Troubleshooting

The troubleshooting information provides possible causes and corrective action required for common problems associated with installation and operation of your product.

Before packing and shipping, all Raymarine products are subjected to comprehensive testing and quality assurance programs. If you do experience problems with your product this section will help you to diagnose and correct problems in order to restore normal operation.

If after referring to this section you are still having problems with your product, please refer to the Technical support section of this manual for useful links and Raymarine Product Support contact details.

21.2 Diagnostic product information

Diagnostic product information can be viewed from your MFD, for products networked using SeaTalkhs® and SeaTalkng® / NMEA 2000.

To view diagnostic product information, select **View all product info** from the **Diagnostics** pop over menu: **Homescreen > Settings > Network > Diagnostics > View all product info**.

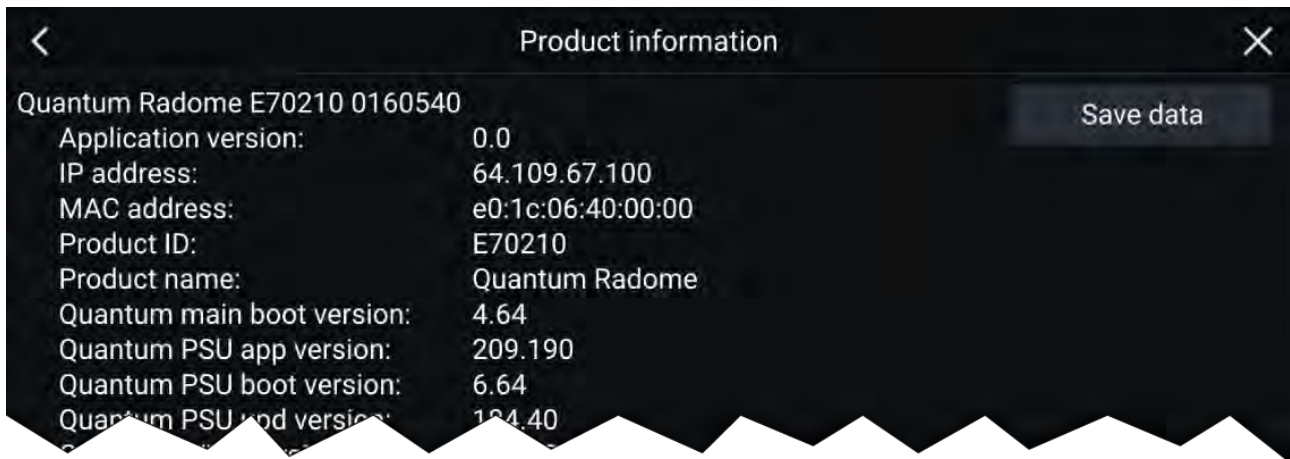

Saving product information

Diagnostic product information can be saved to MicroSD card for off boat records.

With the Diagnostics product information page displayed:

1. Select **Save data**.
2. Select the storage device you want to save the data to.
3. Enter a filename.
4. Select **Save**.
5. Select **OK**.

A .json file will be saved, using your chosen filename to your memory card.

You may view the file using a most standard notepad applications.

21.3 Power up troubleshooting

Product does not turn on or keeps turning off

Possible causes	Possible solutions
Blown fuse / tripped breaker.	<ol style="list-style-type: none"> 1. Check condition of relevant fuses and breakers and connections, replace if necessary. (Refer to the <i>Technical Specification</i> section of your product's installation instructions for fuse ratings.) 2. If fuse keeps blowing check for cable damage, broken connector pins or incorrect wiring.
Poor / damaged / insecure power supply cable / connections	<ol style="list-style-type: none"> 1. Check that the power cable connector is correctly orientated and fully inserted into the display connector and locked in position. 2. Check the power supply cable and connectors for signs of damage or corrosion, and replace if necessary. 3. With the display turned on, try flexing the power cable near to the display connector to see if this causes the unit to restart or lose power. Replace if necessary. 4. Check the vessel's battery voltage and the condition of the battery terminals and power supply cables, ensuring connections are secure, clean and free from corrosion. Replace if necessary. 5. With the product under load, using a multi-meter, check for high voltage drop across all connectors / fuses etc, and replace if necessary.
Incorrect power connection	The power supply may be wired incorrectly, ensure the installation instructions have been followed.

Product will not start up (restart loop)

Possible causes	Possible solutions
Power supply and connection	See possible solutions from the table above, entitled 'Product does not turn on or keeps turning off'.
Software corruption	<ol style="list-style-type: none"> 1. In the unlikely event that the product's software has become corrupted, try downloading and installing the latest software from the Raymarine website. 2. On display products, as a last resort, attempt to perform a 'Power on Reset'. Be aware that this will delete all settings / presets and user data (such as waypoints and tracks), and revert the unit back to factory defaults.



Warning: Factory reset warning

Performing a factory reset will restore all system and app settings to factory defaults and erase all user data (such as waypoints, routes, tracks, camera recordings and photos).

Performing a power on reset — Axiom™

<p>Important:</p> <ul style="list-style-type: none"> • Before performing a power on reset ensure you have backed up your settings and user data (waypoints, routes and tracks) to a memory card. • You may also want to save any crash logs that are stored on your MFD to memory card for future reference..
--

1. Switch off power at the breaker to ensure that the MFD is completely powered off, and not in Standby mode. Alternatively, remove the power cable from the display.
2. Power on your MFD, and within approximately 10 seconds, swipe your finger from right to left (opposite direction to powering on) across the **Power** button swipe area 5 times. Recovery options are displayed.

3. Swipe your finger from right to left twice to highlight **Wipe data/factory reset**.
4. Swipe your finger from left to right once to accept.
5. Swipe your finger from right to left once to highlight **Yes**.
6. Swipe your finger from left to right once to restore your MFD to factory default settings.
7. When **Data wipe complete** is displayed, swipe your finger from left to right to restart your MFD.

Performing a power on reset - Axiom Pro

Important:

Before performing a power on reset ensure you have backed up your settings and user data to a memory card.

1. Switch off power at the breaker to ensure that the MFD is completely powered off, and not in Standby mode. Alternatively, remove the power cable from the display.
2. Within approximately 10 seconds of powering on your MFD, press and hold the **Back** and **Switch active** buttons until the screen goes black and the Raymarine logo appears.
The MFD will boot into Recovery mode.
3. Use the directional controls to highlight **Wipe data/factory reset**.
4. Press **Ok**.
5. Select **Yes** to restore your MFD to factory default settings.
6. When 'Data wipe complete' is displayed, select **Reboot system** now.

Performing a Power on Reset - eS and gS Series MFDs

1. Power the MFD off.
2. Power the MFD back on.
3. When the Raymarine logo appears press and hold the **Power** button, until the Initialization screen is displayed.
4. Press the Waypoint button to restore your MFD to factory default settings.

The MFD will reboot when complete.

21.4 Radar troubleshooting

No connection can be made to the scanner

Possible Causes	Possible Solution
Radar powered down	<ul style="list-style-type: none"> If the scanner product has shut down, power it up by opening the Radar app and selecting the Power icon. A Quantum Radar will shut down after 30 minutes if neither a wired (RayNet) , nor a wireless (Wi-Fi) connection can be made to a MFD.
Radar not transmitting	<ul style="list-style-type: none"> Select Transmit for the relevant Radar scanner from the Radar app.
Missing or incorrect Wi-Fi credentials	<ul style="list-style-type: none"> If using a wireless (Wi-Fi) connection, check that you have entered the correct SSID and passcode for your Radar. Both the SSID and passcode are provided on the Radar scanner's packaging, and are also shown on the serial number label on the underside of the product.
Damaged or disconnected Power cable / RayNet cable	<ol style="list-style-type: none"> Check that the cable connectors are fully inserted and locked in position. Check the power supply cable and connectors for signs of damage or corrosion, replace if necessary. With the product turned on, try flexing the cable near to the display connector to see if this causes the product to re-boot/lose power, replace if necessary. Check the vessel's battery voltage, the condition of the battery terminals and power supply cables, ensuring connections are secure, clean and free from corrosion, replace if necessary. With the product under load, using a multi-meter, check for high voltage drop across all connectors/fuses etc (this can cause the product to reset/turn off), replace if necessary. Check condition of relevant breakers and fuses, replace if necessary. If the breaker keeps tripping or fuses keep blowing, contact a Raymarine authorized dealer for assistance.
Open Array power in Off position	<ul style="list-style-type: none"> Ensure Open Array power switch is in the On position.
Software mismatch between equipment may prevent communication	<ul style="list-style-type: none"> Ensure all Raymarine products contain the latest available software, check the Raymarine website: www.raymarine.com/software for software compatibility.

Poor image quality

Possible Causes	Possible Solution
High network bandwidth usage may interfere with a Quantum Radar connected wirelessly	<ul style="list-style-type: none"> Disconnect Wireless display and close the Wireless display page. Disconnect other devices connected wirelessly.

Displayed bearing is different to the true bearing

Possible Causes	Possible Solution
Bearing alignment adjustment required	<ul style="list-style-type: none"> Carry out the Bearing Alignment procedure.

Radar will not initialize (Voltage control module (VCM) stuck in "sleep mode")

Possible Causes	Possible Solution
Intermittent or poor power connection	Check power connection at VCM. (Voltage at input = 12 / 24 V, Voltage at output = 40 V)

21.5 GNSS (GPS) troubleshooting

No fix displayed

Possible causes	Possible solutions
Geographic location or prevailing conditions preventing satellite fix.	Check to see if a fix is obtained in better conditions or another geographic location.
GNSS (GPS) connection fault.	Ensure that external GNSS (GPS) connections and cabling are correct and fault free.
External GNSS (GPS) receiver in poor location e.g.: <ul style="list-style-type: none"> • Below decks. • Close proximity to transmitting equipment, such as a VHF radio. 	Ensure GNSS (GPS) receiver has a clear view of the sky.
GNSS (GPS) installation problem.	Refer to the installation instructions supplied with your product.

Note: A GNSS (GPS) Status screen is accessible from the display. This provides satellite signal strength and other relevant information.

21.6 Sonar troubleshooting

Scrolling image is not being displayed

Possible causes	Possible solutions
Sonar disabled	Enable Ping from the Fishfinder app's sounder tab: Menu > Settings > Sounder > Ping .
Incorrect transducer selected	Check that the correct transducer is selected in the Fishfinder app's Transducer tab: Menu > Settings > Transducer > Ping .
Damaged cables	<ol style="list-style-type: none"> 1. Check that the transducer cable connector is fully inserted and locked in position. 2. Check the power supply cable and connectors for signs of damage or corrosion, replace if necessary. 3. With the unit turned on, try flexing the cable near to the display connector to see if this causes the unit to re-boot/loose power, replace if necessary. 4. Check the vessel's battery voltage, the condition of the battery terminals and power supply cables, ensuring connections are secure, clean and free from corrosion, replace if necessary. 5. With the product under load, using a multi-meter, check for high voltage drop across all connectors/fuses etc (this can cause the Fishfinder applications to stop scrolling or the unit to reset/turn off), replace if necessary.
Damaged or fouled transducer	Check transducer condition, ensuring it is not damaged and is free from debris/fouling. If necessary, clean or replace your transducer. After cleaning or replacement coat the transducer using a water-based anti-fouling paint.
Wrong transducer fitted	Check product and transducer documentation and ensure that the transducer is compatible with your system.

Possible causes	Possible solutions
External sonar module: SeaTalkhs / RayNet network problem.	<ul style="list-style-type: none"> Check that the unit is correctly connected to the Display or network switch. Check all connections ensuring connections are secure, clean and free from corrosion, replace if necessary.
External sonar module: Software mismatch between equipment may prevent communication.	Ensure all Raymarine products contain the latest available software, check the Raymarine website: www.raymarine.com/software for software compatibility.

No depth reading / lost bottom lock

Possible causes	Possible solutions
Transducer location	Check that the transducer has been installed in accordance with the instructions provided with the transducer.
Transducer angle	If the transducer angle is too great the beam can miss the bottom, adjust transducer angle and recheck.
Transducer kicked-up	If the transducer has a kick-up mechanism, check that it has not kicked up due to hitting an object.
Power source insufficient	With the product under load, using a multi-meter, check the power supply voltage as close to the unit as possible to establish actual voltage when the current is flowing. (Check your product's Technical specification for power supply requirements.)
Damaged or fouled transducer	Check transducer condition, ensuring it is not damaged and is free from debris/fouling. If necessary, clean or replace your transducer. After cleaning or replacement coat the transducer using a water-based anti-fouling paint.
Damaged cables	<ol style="list-style-type: none"> 1. Check the unit's connector for broken or bent pins. 2. Check that the cable connector is fully inserted into the unit and that the locking collar is in the locked position. 3. Check the cable and connectors for signs of damage or corrosion, replace if necessary. 4. With the unit turned on, try flexing the power cable near to the display connector to see if this causes the unit to re-boot/lose power, replace if necessary. 5. Check the vessel's battery voltage, the condition of the battery terminals and power supply cables, ensuring connections are secure, clean and free from corrosion, replace if necessary. 6. With the product under load, using a multi-meter, check for high voltage drop across all connectors/fuses etc (this can cause the Fishfinder applications to stop scrolling or the unit to reset/turn off), replace if necessary.
Vessel speed too high	Slow vessel speed and recheck.
Bottom too shallow or too deep	The bottom depth may be outside of the transducers depth range, move vessel to shallower or deeper waters as relevant and recheck.

Poor / problematic image

Possible causes	Possible solutions
Targets will appear differently if your vessel is stationary (e.g.: fish will appear on the display as straight lines).	Increase vessel speed.
Scrolling paused or speed set too low	Unpause or increase sonar scrolling speed.

Possible causes	Possible solutions
Sensitivity settings may be inappropriate for present conditions.	Check and adjust sensitivity settings or perform a Sonar reset.
Damaged cables	<ol style="list-style-type: none"> 1. Check the unit's connector for broken or bent pins. 2. Check that the cable connector is fully inserted into the unit and that the locking collar is in the locked position. 3. Check the cable and connectors for signs of damage or corrosion, replace if necessary. 4. With the unit turned on, try flexing the power cable near to the display connector to see if this causes the unit to re-boot/loose power, replace if necessary. 5. Check the vessel's battery voltage, the condition of the battery terminals and power supply cables, ensuring connections are secure, clean and free from corrosion, replace if necessary. 6. With the product under load, using a multi-meter, check for high voltage drop across all connectors/fuses etc (this can cause the Fishfinder applications to stop scrolling or the unit to reset/turn off), replace if necessary.
Transducer location	<ul style="list-style-type: none"> • Check that the transducer has been installed in accordance with the instructions provided with the transducer. • If a transom mount transducer is mounted too high on the transom it may be lifting out of the water, check that the transducer face is fully submerged when planing and turning.
Transducer kicked-up	If the transducer has a kick-up mechanism, check that it has not kicked up due to hitting an object.
Damaged or fouled transducer	<p>Check transducer condition, ensuring it is not damaged and is free from debris/fouling. If necessary, clean or replace your transducer.</p> <p>After cleaning or replacement coat the transducer using a water-based anti-fouling paint.</p>
Damaged transducer cable	Check that the transducer cable and connection is free from damage and that the connections are secure and free from corrosion.
Turbulence around the transducer at higher speeds may affect transducer performance	Slow vessel speed and recheck.
Interference from another transducer	<ol style="list-style-type: none"> 1. Turn off the transducer causing the interference. 2. Reposition the transducers so they are farther apart.
Unit power supply fault	Check the voltage from the power supply, if this is too low it can affect the transmitting power of the unit.

21.7 Camera troubleshooting

Video not displayed

Possible causes	Possible solutions
Incorrect power up sequence	Your MFD needs to be powered up before your camera to enable the MFD to provide the camera with a valid IP address.
Camera not compatible.	Ensure the camera feed and network settings are compatible: <ul style="list-style-type: none"> • Camera feed should be set to 720p max. • Network should be set to obtain network address automatically (DHCP). • Anonymous login should be enabled.
Too many IP feeds on network.	Displaying multiple feeds on multiple MFDs simultaneously may cause some feeds to not be displayed. Try viewing less feeds.
Problem with the camera connections.	<ol style="list-style-type: none"> 1. Check the unit's connector for broken or bent pins. 2. Check that the cable connector is fully inserted into the unit and that the locking collar is in the locked position. 3. Check the cable and connectors for signs of damage or corrosion, replace if necessary. 4. With the unit turned on, try flexing the power cable to see if this causes the unit to re-boot/loose power, replace if necessary.
Problem with power supply to the camera or thermal camera's JCU (if used as the primary controller)	<ul style="list-style-type: none"> • Check the power connections to the camera, JCU, and PoE injector (if used). • Ensure that the power switch / breaker is on. • Check the fuse / breaker state.
Camera is in Standby mode.	Use the camera controls (either the Camera app or a Thermal camera's JCU) to "wake" the camera from standby.

PTZ cameras — Erratic or unresponsive controls

Possible causes	Possible solutions
Network problem.	<ul style="list-style-type: none"> • Check that the controller and camera are correctly connected to the network. • If used, check the status of the network switch. • Check that RayNet cables are free from damage.
Control conflict, e.g. caused by multiple users at different stations.	Ensure that no other controllers are in use at the same time.
Problem with the controller.	<ul style="list-style-type: none"> • Check power / network cabling to the controller and PoE injector, if used. • Check other controllers, if available.

Cannot switch between camera feeds

Possible causes	Possible solutions
Camera is not a dual payload model.	Only "dual payload" (dual lens) cameras support feed switching.

Noisy image

Possible causes	Possible solutions
Poor quality or faulty cabling.	<ul style="list-style-type: none">• Ensure cable runs are no longer than they need to be.• Use only high quality shielded cable suitable for the marine environment.
Cable is picking up electromagnetic interference (EMI) from another device.	<ul style="list-style-type: none">• Ensure you are using a high quality shielded cable.• Ensure proper cable separation, for example do not run data and power cables in close proximity with each other.• In certain conditions it may be necessary to fit suppression ferrites to cabling to eliminate interference.

Image too dark or too light

Possible causes	Possible solutions
Brightness set too low.	Check MFD brightness and adjust if necessary.
The contrast and / or brightness settings in the Camera app are set too low.	Check Camera brightness and contrast, adjust if necessary.
The Scene Mode is not appropriate for the current conditions.	When viewing a thermal camera feed, a particular environment may benefit from using a different Scene Mode setting. For example, a very cold background (such as the sky) could cause the camera to use a wider temperature range than appropriate. Adjust the Scene as appropriate.

Image freezes momentarily

Possible causes	Possible solutions
FFC (Flat Field Correction).	A Thermal camera's image will pause momentarily on a periodic basis during the Flat Field Correction (FFC) cycle. Just prior to the FFC, a small green square may appear in the upper left corner of the screen.

Image is inverted (upside down or mirror image)

Possible causes	Possible solutions
Vertical or Horizontal flip control incorrectly set	Check the image flip controls to ensure they are set correctly for your installation.

21.8 Augmented Reality (AR) Troubleshooting

AR options not available in Video app

Possible causes	Possible solutions
Wrong camera selected.	Ensure that the correct AR-compatible camera has been selected in the Video app menu.
Compatible camera not detected.	<ol style="list-style-type: none"> 1. Ensure your camera is AR compatible. 2. Ensure your camera is correctly installed and networked to your MFD.
AR200 not detected.	<ol style="list-style-type: none"> 1. Ensure your AR200 is correctly installed and on the same network as the MFD from which you are using the AR features.
Incorrect LightHouse™ 3 software version.	Ensure that your MFD is running LightHouse™ 3 version 3.7 or above.
AR options turned off.	<p>The Compass bar, AIS, Waypoint and Chart object flags can be enabled and disabled from the ClearCruise settings page (Video app > Menu > Settings > ClearCruise). Ensure relevant options are enabled.</p> <div style="border: 1px solid black; padding: 5px;"> <p>Note:</p> <p>For AIS flags to be displayed, compatible AIS hardware must be operational and connected to the same network as your MFD.</p> </div>

AR flags do not appear directly above on-screen target

Possible causes	Possible solutions
AIS update rate	Depending on the classification of the target's AIS hardware, transmitted position updates may be sent up to 3 minutes apart and therefore the flag may appear up to 3 minutes behind the actual onscreen target.
Camera Field of View (FOV) set incorrectly.	Ensure that the FOV setting reflects your camera's horizontal FOV. Check your camera's documentation for FOV specifications.
AR200 interference	If your AR200 is installed in a location which includes a source of magnetic interference large enough to affect AR flag placement, you may need to re-install the AR200 in a different location.
Deviation too high	<ol style="list-style-type: none"> 1. Reset the AR200 calibration by selecting Reset from the AR200 calibration page: Homescreen > Settings > Network > Data sources > Heading > Raymarine AR200 Attitude > Calibrate. 2. If the problem persists, you may need to move your AR200 to a location with less magnetic interference.

21.9 Wi-Fi troubleshooting

Before troubleshooting problems with your Wi-Fi connection, ensure that you have followed the Wi-Fi location requirements guidance provided in the relevant installation instructions and performed a power cycle/reboot of the devices you are experiencing problems with.

Cannot find network

Possible cause	Possible solutions
Wi-Fi not currently enabled on devices.	Ensure Wi-Fi is enabled on both Wi-Fi devices and rescan available networks.
Some devices may automatically turn off Wi-Fi when not in use to save power.	Power cycle / reboot devices and rescan available networks.
Device not broadcasting.	<ol style="list-style-type: none"> 1. Try to enable broadcasting of the device's network using the Wi-Fi settings on the device you are trying to connect to. 2. You may still be able to connect to the device, when it is not broadcasting, by manually entering the device's Wi-Fi Name / SSID and passphrase in the connection settings of the device you are trying to connect.
Devices out of range or signal being blocked.	Move devices closer together or, if possible remove the obstructions and then rescan available network.

Cannot connect to network

Possible cause	Possible solutions
Some devices may automatically turn off Wi-Fi when not in use to save power.	Power cycle/reboot devices and retry the connection.
Trying to connect to the wrong Wi-Fi network	Ensure you are trying to connect to the correct Wi-Fi network, the Wi-Fi network's name can be found in the Wi-Fi settings on the broadcasting device (the device that you are trying to connect to).
Incorrect network credentials	Ensure you are using the correct passphrase, the Wi-Fi network's passphrase can be found in the Wi-Fi settings on the broadcasting device (the device that you are trying to connect to).
Bulkheads, decks and other heavy structure can degrade and even block the Wi-Fi signal. Depending on the thickness and material used it may not always be possible to pass a Wi-Fi signal through certain structures	<ol style="list-style-type: none"> 1. Try repositioning the devices so the structure is removed from the direct line of sight between the devices, or 2. If possible use a wired connection instead.
Interference being caused by other Wi-Fi enabled or older Bluetooth enabled devices (Bluetooth and Wi-Fi both operate in the 2.4 GHz frequency range, some older bluetooth devices may interfere with Wi-Fi signals.)	<ol style="list-style-type: none"> 1. Change the Wi-Fi Channel of the device you are trying to connect to and retry the connection. You can use free Wi-Fi analyzer apps on your smart device to help you choose a better channel (channel with least traffic). 2. Temporarily disable each wireless device in turn until you have identified the device causing the interference.

Possible cause	Possible solutions
<p>Interference caused by other devices that use the 2.4GHz frequency See list below of some common devices that use the 2.4GHz frequency:</p> <ul style="list-style-type: none"> • Microwave ovens • Fluorescent lighting • Cordless phones / baby monitors • Motion sensors 	<p>Temporarily switch off each device in turn until you have identified the device causing the interference, then remove or reposition the offending device(s).</p>
<p>Interference caused by electrical and electronic devices and associated cabling could generate an electromagnetic field which may interfere with the Wi-Fi signal.</p>	<p>Temporarily switch off each item in turn until you have identified the device causing the interference, then remove or reposition the offending device(s).</p>

Connection extremely slow and or keeps dropping out

Possible cause	Possible solutions
<p>Wi-Fi performance degrades over distance so products farther away will receive less network bandwidth. Products installed close to their maximum Wi-Fi range will experience slow connection speeds, signal drop outs or not being able to connect at all.</p>	<ul style="list-style-type: none"> • Move devices closer together. • For fixed installations such as a Quantum Radar, enable the Wi-Fi connection on an MFD installed closer to the device.
<p>Interference being caused by other Wi-Fi enabled or older Bluetooth enabled devices (Bluetooth and Wi-Fi both operate in the 2.4 GHz frequency range, some older bluetooth devices may interfere with Wi-Fi signals.)</p>	<ol style="list-style-type: none"> 1. Change the Wi-Fi Channel of the device you are trying to connect to and retry the connection. You can use free Wi-Fi analyzer apps on your smart device to help you choose a better channel (channel with least traffic). 2. Temporarily switch off each device in turn until you have identified the device causing the interference, then remove or reposition the offending device(s).
<p>Interference from devices on other vessels. When in close proximity to other vessels, for example, when moored up in a marina, many other Wi-Fi signals may be present.</p>	<ol style="list-style-type: none"> 1. Change the Wi-Fi Channel of the device you are trying to connect to and retry the connection. You can use free Wi-Fi analyzer apps on your smart device to help you choose a better channel (channel with least traffic). 2. If possible, move your vessel to a location with less Wi-Fi traffic.

Network connection established but no data

Possible cause	Possible solutions
<p>Connected to the wrong network.</p>	<p>Ensure that your devices is connected to the correct network.</p>
<p>Device software incompatibility</p>	<p>Ensure both devices are running the latest available software.</p>
<p>It may be possible that the device has become defective</p>	<ol style="list-style-type: none"> 1. Try updating software to a later version, or 2. try reinstalling the software. 3. Obtain new replacement device.

Mobile application running slowly or not at all

Possible cause	Possible solutions
Raymarine app not installed	Install mobile app from relevant app store.
Raymarine app version not compatible with MFD software	Ensure mobile app and MFD software are latest available versions.
Mobile apps not enabled on MFD	Enable “Viewing only” or “Remote Control” as required in the Mobile Apps setting on your MFD.

21.10 Wireless display troubleshooting

Cannot connect to wireless display

Possible cause	Possible solutions
Some Miracast compatible but non certified devices may not be able to connect with Wi-Fi Sharing enabled.	Disable Wi-Fi Sharing on your MFD and retry connection.
WiFi Sharing has been enabled or disabled since the wireless display was first connected.	Try power cycling devices and trying again. Depending on dongle used a factory reset may be required to establish a connection.
Missed confirmation on wireless display	Restart connection procedure and ensure you check the wireless display for confirmation dialogs.
Wireless display too far away	Try moving the wireless display closer to the MFD and retry connection.
Chromecast devices are not supported.	Purchase a Miracast compatible device.

Poor performance

Possible cause	Possible solutions
High video processing demand.	The Camera app, Raymarine mobile app connections can interfere with the wireless display performance as they use shared video processing resource. Try switching off video feeds and/or mobile app connections.
Wireless display too far away	Try moving the wireless display closer to the MFD and retry connection.

Wireless display disconnects

Possible cause	Possible solutions
Changing the Wi-Fi Sharing option on your MFD will cause the wireless display to disconnect.	Do not change Wi-Fi sharing options whilst connected to a wireless display. Wireless display may require factory reset to re-establish connection.
Quantum wireless pairing process will cause wireless display to disconnect.	Do not pair with a Quantum Radar whilst wireless display connection is active.
Wireless display too far away	Try moving the wireless display closer to the MFD and retry connection.

21.11 Data troubleshooting

Instrument, engine or other system data is unavailable at all displays

Possible causes	Possible solutions
Data is not being received at the display(s).	<ul style="list-style-type: none"> • Check transmitted data is compatible with your display. Refer to MFD supported PGN list. • Check the data bus (e.g. SeaTalk^{ng}) wiring and connections.
Data source (e.g. instrument display or engine interface) is not operating.	<ul style="list-style-type: none"> • Check the source of the missing data (e.g. instrument display or engine interface). • Check power to the data bus.
Software mismatch between equipment may prevent communication.	<ul style="list-style-type: none"> • Check the Raymarine website and ensure all your Raymarine products have the latest software.

Instrument or other system data is missing from some but not all displays

Possible causes	Possible solutions
Network connection problem.	<ul style="list-style-type: none"> • Check that all required equipment is connected to the same network. • Check correct operation of network switch, if used. • Check network cabling is correct and free from damage.
Software mismatch between equipment may prevent communication.	Check all MFDs are using the same version of software.

21.12 Touchscreen troubleshooting

Touchscreen does not operate as expected.

Possible causes	Possible solutions
Touch lock is enabled.	Disable TouchLock, using the power button..
Screen is not being operated with bare fingers, for example gloves are being worn.	Bare fingers must make contact with the screen for correct operation. Alternatively you may use conductive gloves.
Saltwater deposits on the screen.	Carefully clean and dry the screen with a damp non-abrasive cloth.

Chapter 22: Technical support

Chapter contents

- [22.1 Raymarine product support and servicing on page 358](#)
- [22.2 Learning resources on page 360](#)

22.1 Raymarine product support and servicing

Raymarine provides a comprehensive product support service, as well as warranty, service, and repairs. You can access these services through the Raymarine website, telephone, and e-mail.

Product information

If you need to request service or support, please have the following information to hand:

- Product name.
- Product identity.
- Serial number.
- Software application version.
- System diagrams.

You can obtain this product information using diagnostic pages of the connected MFD.

Servicing and warranty

Raymarine offers dedicated service departments for warranty, service, and repairs.

Don't forget to visit the Raymarine website to register your product for extended warranty benefits: <http://www.raymarine.co.uk/display?id=788>.

Region	Contact
United Kingdom (UK), EMEA, and Asia Pacific	<ul style="list-style-type: none">• E-Mail: emea.service@raymarine.com• Tel: +44 (0)1329 246 932
United States (US)	<ul style="list-style-type: none">• E-Mail: rm-usrepair@flir.com• Tel: +1 (603) 324 7900

Web support

Please visit the “Support” area of the Raymarine website for:

- **Manuals and Documents** — <http://www.raymarine.com/manuals>
- **Technical support forum** — <http://forum.raymarine.com>
- **Software updates** — <http://www.raymarine.com/software>

Worldwide support

Region	Contact
United Kingdom (UK), EMEA, and Asia Pacific	<ul style="list-style-type: none">• E-Mail: support.uk@raymarine.com• Tel: +44 (0)1329 246 777
United States (US)	<ul style="list-style-type: none">• E-Mail: support@raymarine.com• Tel: +1 (603) 324 7900 (Toll-free: +800 539 5539)
Australia and New Zealand (Raymarine subsidiary)	<ul style="list-style-type: none">• E-Mail: aus.support@raymarine.com• Tel: +61 2 8977 0300
France (Raymarine subsidiary)	<ul style="list-style-type: none">• E-Mail: support.fr@raymarine.com• Tel: +33 (0)1 46 49 72 30
Germany (Raymarine subsidiary)	<ul style="list-style-type: none">• E-Mail: support.de@raymarine.com• Tel: +49 (0)40 237 808 0
Italy (Raymarine subsidiary)	<ul style="list-style-type: none">• E-Mail: support.it@raymarine.com• Tel: +39 02 9945 1001
Spain (Authorized Raymarine distributor)	<ul style="list-style-type: none">• E-Mail: sat@azimut.es• Tel: +34 96 2965 102
Netherlands (Raymarine subsidiary)	<ul style="list-style-type: none">• E-Mail: support.nl@raymarine.com• Tel: +31 (0)26 3614 905

Region	Contact
Sweden (Raymarine subsidiary)	<ul style="list-style-type: none"> E-Mail: support.se@raymarine.com Tel: +46 (0)317 633 670
Finland (Raymarine subsidiary)	<ul style="list-style-type: none"> E-Mail: support.fi@raymarine.com Tel: +358 (0)207 619 937
Norway (Raymarine subsidiary)	<ul style="list-style-type: none"> E-Mail: support.no@raymarine.com Tel: +47 692 64 600
Denmark (Raymarine subsidiary)	<ul style="list-style-type: none"> E-Mail: support.dk@raymarine.com Tel: +45 437 164 64
Russia (Authorized Raymarine distributor)	<ul style="list-style-type: none"> E-Mail: info@mikstmarine.ru Tel: +7 495 788 0508

Viewing product information (LightHouse™ 3)

Use the **Settings** menu to view hardware and software information about your MFD, and connected products.

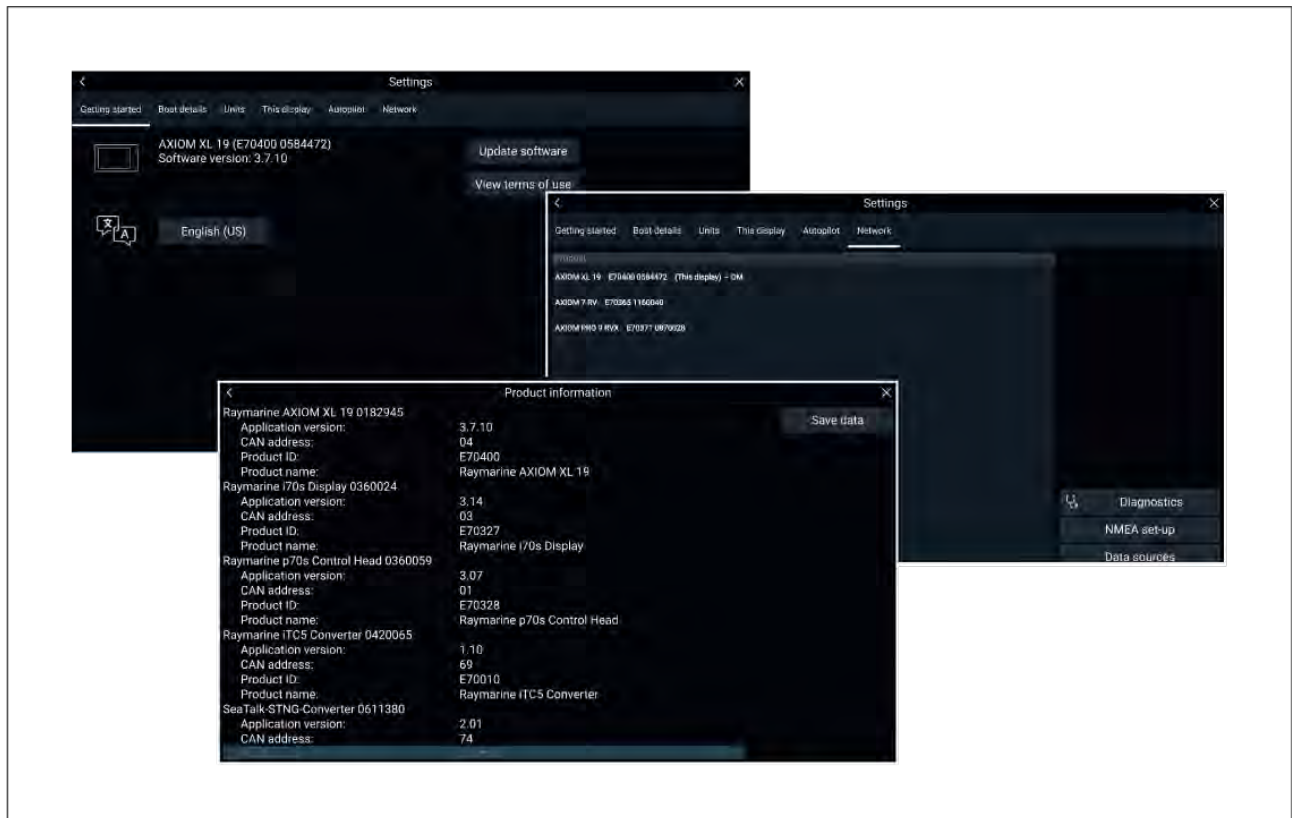



1. Select **Settings**, from the Homescreen.
The **Getting started** menu contains hardware and software information for your MFD.
2. You can view further information about your MFD, or view information about products networked using SeaTalkhs® and SeaTalkng® / NMEA 2000, by selecting the **Network** tab, then:
 - i. to display detailed software information and your MFD's network IP address, select your MFD from the list.
 - ii. to display detailed diagnostics information for all products, select **Product info** from the **Diagnostics** pop over menu.

22.2 Learning resources

Raymarine has produced a range of learning resources to help you get the most out of your products.

Video tutorials

	<p>Raymarine official channel on YouTube:</p> <ul style="list-style-type: none">• YouTube <p>LightHouse™ 3 tips and tricks:</p> <ul style="list-style-type: none">• Raymarine website
	<p>Video Gallery:</p> <ul style="list-style-type: none">• Raymarine website

Note:

- Viewing the videos requires a device with an Internet connection.
- Some videos are only available in English.

Training courses

Raymarine regularly runs a range of in-depth training courses to help you make the most of your products. Visit the Training section of the Raymarine website for more information:

- <http://www.raymarine.co.uk/view/?id=2372>

Technical support forum

You can use the Technical support forum to ask a technical question about a Raymarine product or to find out how other customers are using their Raymarine equipment. The resource is regularly updated with contributions from Raymarine customers and staff:

- <http://forum.raymarine.com>

Appendix A NMEA 0183 sentence support

Sentence	Description	Transmit	Receive
APB	Heading / Track controller pilot sentence "B"	•	•
BWC	Bearing & distance to waypoint — great circle	•	•
BWR	Bearing & distance to waypoint — rhumb line	•	•
DBT	Depth below transducer	•	•
DPT	Depth	•	•
GGA	GNSS (GPS) fix data	•	•
GLL	Geographic position lat/long	•	•
GSA	GNSS (GPS) DOP & active satellites	•	•
GSV	GNSS (GPS) satellites in view	•	•
MTW	Water temperature	•	•
MWV	Wind speed & angle	•	•
RMA	Recommended minimum specific Loran C data	•	•
RMB	Recommended minimum navigation information	•	•
RMC	Recommended minimum specific GNSS (GPS) data	•	•
RSD	Radar system data	•	•
TTM	Tracked target message	•	•
VHW	Water speed and heading	•	•
VLW	Dual ground/water distance	•	•
VTG	COG (Course Over Ground) & ground speed	•	•
ZDA	Time & date	•	•

Appendix B NMEA 2000 PGN support

PGN	Description	Transmit	Receive
59392	ISO Acknowledgment	•	•
59904	ISO Request	•	•
60928	ISO Address Claim	•	•
126208	NMEA - Request group function	•	•
126464	Receive/Transmit PGN's group function	•	•
126992	System Time	•	•
126996	Product Information	•	•
127237	Heading/Track Control		•
127245	Rudder		•
127250	Vessel Heading	•	•
127488	Engine Parameters, Rapid Update		•
127489	Engine Parameters, Dynamic		•
127493	Transmission Parameters, Dynamic		•
127496	Trip Parameters, Vessel		•
127497	Trip Parameters, Engine		•
127498	Engine Parameters, Static		•
127505	Fluid Level		•
127506	DC Charge Status		•
128259	Speed	•	•
128267	Water Depth	•	•
128275	Distance Log	•	•
129025	Position, Rapid Update	•	•
129026	COG & SOG, Rapid Update	•	•
129029	GNSS Position Data	•	•
129033	Time & Date	•	•
129038	AIS Class A Position Report		•
129039	AIS Class B Position Report		•
129040	AIS Class B Extended Position Report		•
129041	AIS Aids to Navigation (AtoN) Report		•
129044	Datum	•	•
129283	Cross Track Error	•	•
129284	Navigation Data	•	•
129291	Set & Drift, Rapid Update	•	•
129301	Time to/from Mark		•
129539	GNSS DOPs		•
129540	GNSS Sats in View	•	•
129545	GNSS RAIM Output		•
129550	GNSS Differential Correction Receiver Interface		•
129551	GNSS Differential Correction Receiver Signal		•
129793	AIS UTC and Date Report		•
129794	AIS Class A Static and Voyage Related Data		•

PGN	Description	Transmit	Receive
129801	AIS Addressed Safety Related Message		•
129802	AIS Safety Related Broadcast Message		•
129808	DSC call information		•
129809	AIS Class B "CS" Static Report, Part A		•
129810	AIS Class B		•
130306	Wind Data	•	•
130310	Environmental Parameters	•	•
130311	Environmental Parameters		•
130576	Small Craft Status		•
130577	Direction Data	•	•
130578	Vessel Speed Components		•

Raymarine® provides field programmability of the Device and System Instances within PGN 60928 which can be commanded via use of PGN 126208 as required by the latest **NMEA 2000** standard.

Appendix C Document change history

Document revision and (Date)	Software version	Changes
81370–14 (10–2019)	LH3.11	<ul style="list-style-type: none"> • Added new Responder Messaging feature to Homescreen chapter. • Added new iTC–5 Calibration feature to Set up chapter. • Added new Fishidy Sync mobile app to to Mobile app support chapter. • Updated SAR patterns with Expanding Square pattern in the Chart app chapter. • Added new Victron app to LightHouse third-party apps chapter. • Updated Video app chapter with Dual streaming. • Added M-Series settings compatibility table to Video app chapter. • Added Pilot track mode and Search route arrival to the Alarm settings table in the Homescreen chapter.
81370–13 (09–2019)	LH3.10.71	<ul style="list-style-type: none"> • Added M300-Series maritime camera to compatible cameras in ClearCruise™ chapter.
81370–12 (07–2019)	LH3.10	<ul style="list-style-type: none"> • Added new camera settings to Video app chapter. • Added new Race Sailing features, Race Start Line and Race Timer to the Chart app and Dashboard app. • Added new Responder setup information to the Homescreen chapter and SITREP feature to Chart app chapter. • Added new SR200 diagnostics to the Audio app chapter. • Updated SR200 network requirements in the Weather mode chapter. • Added new PDF viewer app chapter. • Updated data overlay and sidebar data items table with new wind data. • Added details of new Buoyweather, Shadow-Caster, PredictWind and Offshore to LightHouse™ apps.
81370–11 (04–2019)	LH3.9	<ul style="list-style-type: none"> • Added new Blank sectorsto Radar app chapter. • Added ClearCruise™ Augmented Reality support and installation for M100/M200 series thermal cameras to ClearCruise chapter. • Added new Fusion Multi-zone volume control to Audio app. • Updated UAV app with DJI Mavic 2 Pro and DJI Mavic 2 zoom drone support. • Added new RealBathy real-time sonar map generator feature to the Chart app chapter. • Added new Sailing laylines feature to the Chart app chapter. • Updated Dashboard app with sailing page and sailing dials. • Changed Sonar app to Fishfinder app, document wide. • Updated Weather chapter and Audio app chapter with SR200 compatibility. • Updated Boat details section in the Homescreen chapter with new Tank calibration options. • Added new Yamaha engine integration app chapter.

Document revision and (Date)	Software version	Changes
81370-10 (12-2018)	LH3.8	<ul style="list-style-type: none"> • Added new Search and Rescue (SAR) Patterns feature to Chart app chapter. • Added new Collision Avoidance and Target Intercept features to Chart app chapter. • Added Install third-party apps to Lighthouse third-party apps chapter. • Updated Chart app with Chart sync setting. • Added Regulatory approvals to settings. • Updated Limitations on use. • Updated Data Overlays with Loran Data Overlays. • Added Rudder bar to Sidebar. • Updated Audio app with JL Audio compatibility.
81370-9 (09-2018)	LH3.7	<ul style="list-style-type: none"> • Added new ClearCruise™ chapter which documents Object Detection and Augmented Reality. • Added details of new Display estimated range setting for ClearCruise™ Object detection in Video app. • Updated Video app settings menu section with new ClearCruise™ options. • Added details of new Seakeeper and Mazu LightHouse™ apps. • Expanded My data details to include MFD settings import and export (backup). • Added new tasks for Saving user data, saving MFD settings, restoring user data and restoring MFD settings. • Added custom “Digital switching” pages export feature to Dashboard app. • Added AR200 to hardware compatibility table. • Moved Axiom XL compatibility from LightHouse V3.5 to V3.7.
81370-8 81370-7 (07-2018)	LH3.6	<ul style="list-style-type: none"> • Updated software revision and new features section to reflect V3.6. • Added description of each available MFD app to Homescreen section. • Added new UAV app chapter. • Added UAV chart integration details to Chart app chapter. • Updated hardware compatibility list to include Mavic Pro and Mavic Pro Platinum UAVs.
81370-6 (06-2018)	LH3.5	<ul style="list-style-type: none"> • Updated software revision and new features section to reflect V3.5. • Added support for MFD alarms via Bluetooth speaker. • Updated list of compatible entertainment systems in Audio app chapter to include new Fusion units and SR150, also added new column to list supported network connections. • Updated Audio app chapter settings menu options to include Balance and Fade. • Updated Audio app chapter details to allow for multiple systems to be connected and controlled. • Added PDF viewer details. • Updated demo profiles section to detail the new demo movie option. • Updated NMEA 2000 PGN list to include 127506 and 129808. • Updated compatible MFDs to include Axiom XL • Updated product documentation to include Axiom XL installation instructions. • Added new details for using SonarChart Live to Chart app chapter.

Document revision and (Date)	Software version	Changes
		<ul style="list-style-type: none"> • Updated LH2 Vs LH3 feature gap on eS and gS Series. • Added LH3 version Vs supported hardware list to appendix. • Updated Radar chapter to include Magnum open array details. • Added new details/requirements for LH apps.
81370–5 (02–2018)	LH3.4	<ul style="list-style-type: none"> • Added LightHouse 2 to LightHouse 3 upgrade procedure to applicable documents. • Updated software revision to V3.4. • Updated New features section to reflect V3.4 new features. • Change chapter title for ‘General app settings’ to ‘General information’. • Added new definition of MFD app and LightHouse app to General info chapter. • Updated shortcuts page details to include Bluetooth speaker volume control. • Added new Bluetooth volume control instructions. • Added new Bluetooth speaker pairing procedure. • Updated Homescreen screenshots to reflect LH3.4 UI throughout the manual. • Updated Homescreen overview to include details of Apps icon. • Updated status area details to include Bluetooth volume controls and Disengage autopilot icon. • Added Bluetooth and Disengage autopilot icons to Status area table. • Removed Wi-Fi symbols from status area icons table and grouped icons in separate tables. • Updated trip log details to include new combined Fuel/trip manager details and settings. • Alarms section re-written to include examples of Blue, Orange and Red notifications. • Added Alarm history and Alarm indicators to Alarms section. • Added Digital switching alarm details and example screenshot. • Added Shared brightness details. • Added procedure for customizing the splashscreen. • Added new LightHouse apps chapter, including Wi-Fi and Bluetooth connection and settings.. • Updated Disengaging autopilot details to include Status area location of autopilot icon. • Added new Tides mode details. • Added new Find nearest feature details. • Added new ‘Other’ vessel AIS icon and Changed current ‘Other’ icon to ‘Commercial’. • Updated Radar chapter to include Quantum 2 support. • Added Doppler Radar feature. • Updated Fuel related data items available in Dashboard app. • Updated Camera app overview to include details of creating unique app instances on different displays. • Renamed ‘Camera app’ now ‘Video app’.

Document revision and (Date)	Software version	Changes
81370-4 (11-2017)	LH3.3	<ul style="list-style-type: none"> • Updated New features list to reflect LH3.3. • Added RV transducer calibration details. • Added MFD controls information for eS Series and gS Series. • Added new LH3 compatible MFDs table. • Updated Radar target tracking to include AIS targets. • Updated Radar target settings information to include independent Reference mode for targets, and new Trails settings. • Added new Weather mode chapter. • Updated User interface languages table. • Added lists of data items available in Dashboard app and for data overlays and sidebars. • Added Navionics plotter sync details to Mobile app chapter. • Added diagnostic product information details to troubleshooting chapter. • Added LH2 to LH3 upgrade procedure to Appendix. • Updated RV Depth and intensity setting details. • Updated shortcuts page information to include new Disable all sounders option.
81370-3 (09-2017)	LH3.2	<ul style="list-style-type: none"> • Updated software revision to reflect LH3.2. • Updated New features section to reflect LH3.2. • Added User programmable button details for Axiom Pro MFDs. • Updated Software updates section to reflect updating SeaTalkng products. • Added wireless display information, connection details and troubleshooting. • Added NMEA0183 setting for Axiom Pro MFDs. • Added Autorouting related information and procedures. • Updated Chart selection information to include C-MAP cartography. • Added AIS symbols tables. • Updated Chart settings tables to include C-MAP specific and Enhanced Navionics cartography features support. • Added Sailing and Navigation dial overview to Dashboard chapter. • Updated Camera app overview to include analog feeds via an Axiom Pro. • Updated Audio app compatible entertainment systems to include compatible Rockford Fosgate and Fusion units. • Updated Radar troubleshooting to include high network bandwidth. • Added NMEA0183 supported sentences table.
81370-2 (07-2017)	LH3.1	<ul style="list-style-type: none"> • Updated software revision to reflect LH3.1. • Added controls details for Axiom and Axiom Pro • Added powering on and off details for Axiom Pro. • Removed Data source type table from Data sources. • Re-ordered Data source and MDS paragraphs. • Moved Factory reset procedure to para 3.3. • Added Pilot controls to shortcuts page. • Re-ordered memory card paragraphs and added details for Axiom Pro.

Document revision and (Date)	Software version	Changes
		<ul style="list-style-type: none"> • Added details for software updating networked MFDs. • Removed restriction of RMK pilot button in LH3 and added new step for repeating pairing process on each MFD. • Updated Homescreen overview to include Disengage pilot icon. • Added Wi-Fi sharing and Mobile app details to This display setting tab. • Added new Autopilot tab to Settings menu. • Added table of available UI languages. • Removed device disconnection details from External devices options. • Added new Autopilot control chapter. • Added details for switching between Sidebars. • Added camera tracking (Point camera here and Track with camera controls to Chart and Radar chapters. • Added details for placing waypoints in RV channels. • Added details of Sonar scroll back. • Added details of sensitivity adjustments effecting sonar scroll back. • Added View mode in RV channel settings to switch between scrolling and GPS tracking modes. • Added details of AHRS stabilization control in Sounder tab settings. • Added new Mobile app support chapter. • Added document change history to appendix.
81370-1 (04-2017)	LH3.0	First release.

Appendix D Hardware compatibility

The table below identifies the LightHouse™ 3 software version required to support the listed hardware.

Software version	Hardware
LH3.11	<ul style="list-style-type: none"> • Victron Energy Venus GX
LH3.10.71	<ul style="list-style-type: none"> • M300-Series
LH3.9	<ul style="list-style-type: none"> • SR200 SiriusXM receiver (weather and audio) • DJI Mavic 2 Pro UAV • DJI Mavic 2 Zoom UAV
LH3.8	<ul style="list-style-type: none"> • JL Audio
LH3.7	<ul style="list-style-type: none"> • AR200 Augmented Reality Sensor • Axiom XL
LH3.6	<ul style="list-style-type: none"> • DJI Mavic Pro UAV • DJI Mavic Pro Platinum UAV
LH3.5	<ul style="list-style-type: none"> • Fusion 770 and SRX400 • SR150 SiriusXM receiver (audio)
LH3.4	<ul style="list-style-type: none"> • Magnum Radar • Quantum 2 Doppler Radar • RVX1000 sonar module • Bluetooth speaker • Axiom XL 16
LH3.3	<ul style="list-style-type: none"> • SR150 SiriusXM receiver (weather only) • eS Series (upgraded to LH3) • gS Series (upgraded to LH3)
LH3.2	<ul style="list-style-type: none"> • Axiom Pro • Fusion entertainment systems (NMEA 2000 only)
LH3.1	<ul style="list-style-type: none"> • Evolution autopilots • RMK-10 • Quantum Radar
LH3.0	<ul style="list-style-type: none"> • Axiom

Appendix E LightHouse 3 on eS and gS Series

eS Series and gS Series MFDs running the LightHouse™ 2 operating system can be upgraded to run the new LightHouse™ 3 operating system version 3.3 or greater.



To ensure upgrading is the correct option for you, please ensure you fully understand and accept the differences between the 2 operating systems, before upgrading.

Upgrade considerations

Before you perform the upgrade, the following considerations need to be taken into account:

Digital switching

Upgrading to LightHouse™ 3 will erase all Digital switching files loaded on your MFD. Once erased, these files will be unrecoverable, potentially rendering the Digital switching system unusable.

Digital switching solutions must be converted, before performing the upgrade to LightHouse™ 3. Contact Raymarine Technical Support, who will guide you through the process and perform the necessary file conversion.

Autopilots

Legacy SeaTalk® and SPX autopilots cannot be controlled by MFDs running LightHouse™ 3. A Pilot control head will be required to control legacy autopilot systems.

MFD networking

- LightHouse™ 2 MFDs cannot be connected to the same network as LightHouse™ 3 MFDs.
- a Series, c Series and e Series MFDs cannot be upgraded to LightHouse™ 3 and cannot be connected to the same network as MFDs running LightHouse™ 3.
- If you have a mixed MFD network all a Series, c Series and e Series MFDs must be permanently disconnected, before upgrading eS Series and gS Series MFDs to LightHouse™ 3.
- In a mixed Axiom™ / eS Series / gS Series MFD network, it is recommended that an Axiom™ MFD is selected as the Datamaster. Where this is not desirable, due to your electronics wiring layout, you may notice a difference in system performance when an eS Series or gS Series MFD is set as Datamaster.

MFD performance

LightHouse™ 3 was developed for use with the latest processing technology, utilized by Axiom™ MFDs. Performance of eS Series and gS Series MFDs upgraded to use LightHouse™ 3 will be limited to the processing power available to the MFD.

Unsupported features

The following features are only supported by Axiom variant MFDs and will not be available on an eS Series or gS Series MFD upgraded to run LightHouse™ 3.

- Checking online for software updates.
- The Wireless (Miracast) display.
- LightHouse third-party apps.
- Customizable splashscreen.
- Bluetooth audio output.
- UAV integration
- ClearCruise™ Augmented Reality

Compatible MFDs

The MFDs listed below can be upgraded to run Raymarine's new LightHouse™ 3 operating system.

eS Series MFDs

eS75 (E70263)	eS77 (E70264)
eS78 (E70265)	eS97 (E70274)
eS98 (E70275)	eS127 (E70275)
eS128 (E70285)	

gS Series MFDs

gS95 (E70124)	gS95 INV (E70183)
gS125 (E70125)	gS125 INV (E70184)
gS165 (E70126)	gS165 INV (E70185)
gS195 (E70213)	

Feature differences

The table below shows the differences between LightHouse™ 2 R19 and LightHouse™ 3 version 3.3 (LH3.3) and above, running on an **eS Series** or **gS Series** MFD. If in any doubt, contact Raymarine Technical Support for advice.

Navigation

Feature	LightHouse™ 2	LightHouse™ 3
3D chart mode	Yes	No
Number of Boat icons	2 – changes automatically with boat type selection.	12 – independent selection.
Boat icon context menu	No	Yes
Chart measurement ruler	Yes	No
Chart synchronization – split screen pages	Yes	LH3.8
Collision avoidance	Yes	LH3.8
Enhanced AIS symbols	No	Yes
Find nearest (info)	Yes	LH3.4
Fuel manager	Yes	LH3.4
GRIB weather viewer	Yes	No
Nearby objects (selection)	No	Yes
Race sailing features	Yes	LH3.10
Sailing laylines	No	LH3.9
SAR (Search And Rescue) patterns	Yes	LH3.8
Target interception	Yes	LH3.8
Tide and Current graphs	Yes	LH3.4

Feature	LightHouse™ 2	LightHouse™ 3
Waypoint capacity	3,000	10,000
Waypoint search area box	Yes	No

Data and controls

Feature	LightHouse™ 2	LightHouse™ 3
Alarm history	Yes	LH3.4
Databars	Top Databar	Sidebar
Available data items	117	LH3.4 = 134 LH3.5 = 137
Dashboard — more available page layouts	10	7
Dashboard — each app instance unique	No	Yes
Digital switching alarm settings	Yes	LH3.4
Light color theme	Yes	No
Shared brightness	Yes	LH3.4

Sonar

Feature	LightHouse™ 2	LightHouse™ 3
Channel specific Homescreen sonar icons	No	Yes
Number of DownVision and SideVision color palettes	4	10
Fish alarm	Yes	No
Historical sensitivity	No	Yes
Range/zoom controls	Standard	Enhanced
RealBathy™	No	LH3.9
* RealVision™ 3D	No	Yes
SideVision — Auto range	No	Yes
Scrollback (sonar history)	No	Yes
Disable all Sonar from Shortcuts page	No	Yes
VRM (Variable Range Marker)	Yes	No

Note:

* Available when networked to a RV variant Axiom™ or Axiom™ Pro MFD.

Radar

Feature	LightHouse™ 2	LightHouse™ 3
Bearing ring	Standard	Enhanced
Blank sectors	No	LH3.9
Place waypoints in Radar app	Yes	No
Radar overlay color options	No	Yes
True/Relative vector button	No	Yes
Doppler Radar support	No	LH3.4

Camera / Thermal

Feature	LightHouse™ 2	LightHouse™ 3
Align Thermal camera to mobile device	Yes	No
ClearCruise™ Augmented Reality	No	LH3.7
ClearCruise™ Object detection	No	Yes
Single app for both Thermal and daylight cameras	No	Yes
Unique Camera app instances	No	Yes
Camera cycling	Yes	No
Dual payload camera dual streaming	No	LH3.11

Entertainment

Feature	LightHouse™ 2	LightHouse™ 3
Bluetooth audio control	Yes	No
Bluetooth — RCU-3 connection	Yes	No
PDF viewer app	Yes	3.5 (PDF viewer dialog) 3.10
JL Audio	No	LH3.8
SiriusXM audio	Yes	LH3.5
Video player (demo movie)	Yes	LH3.5

General

Feature	LightHouse™ 2	LightHouse™ 3
Active alarm indication	No	LH3.4
Alarm Clock / Timer	Yes	No
MFD app modes	No	Yes
Custom splash screens	Yes	No
Number of Data overlays	2	4
Data overlays movable	No	Yes
Homescreen — Lat/Lon display	No	Yes
Homescreen — Move pages	Yes	No
Homescreen — Time info	No	Yes
Homescreen customization — drag and drop app pages	Yes	No
Menus — close when tapping away from menu	No	Yes
NMEA Logging	Yes	No
LiveView (in menu app display)	No	Yes
Sidebar	No	Yes
Simulated — Demo profiles	No	Yes
Simulator — Move boat here	No	Yes
Splitscreen app page — pane size adjustment	No	Yes
Third-party app installation from card	No	LH3.8
Transducer calibration	Yes	No
User profiles	No	Yes

Engine integration

Feature	LightHouse™ 2	LightHouse™ 3
Honda ECO mode	Yes	LH3.4
Trim tab calibration	Yes	No
Yamaha app	No	LH3.9

Performing the LightHouse™ 3 upgrade

Performing the upgrade procedure will upgrade all eS Series and gS Series MFDs on the network.

Pre-requisites:

- Your eS or gS Series MFD must be running LightHouse™ 2 Release 15 or greater to perform the upgrade. Prior releases of LightHouse™ 2 will not recognise the software upgrade file.
 - You should back up your user data and any media files before performing the upgrade.
1. Disconnect and remove any a Series, c Series or e Series MFDs from your network.
 2. Download the LightHouse™ 3 upgrade file from the Raymarine® website:
 - i. Go to ww.raymarine.com/software.
 - ii. Click **MFD software**.
 - iii. Click **eS & gS Series Models Only**.
 - iv. Follow the instructions to download the upgrade file.
 3. Perform a User data backup following the [Saving all user data to a memory card](#) procedure.
 4. If you have any media files saved on your MFD that you want to keep, these should also be copied to a MicroSD card following the [Copying media files](#) procedure.
 5. Copy the downloaded upgrade file to the root directory of your MicroSD card, ensuring that no other software update files are present on the card.
 6. Insert the MicroSD card into a card reader slot on your MFD.
 7. Perform the software update procedure:
 - i. Select **Check Card for Updates** from the Maintenance menu: (**Homescreen > Set-up > Maintenance > Check Card for Updates**).
 - ii. Select **OK**.
 - iii. Select the check box for each MFD that you want to upgrade.

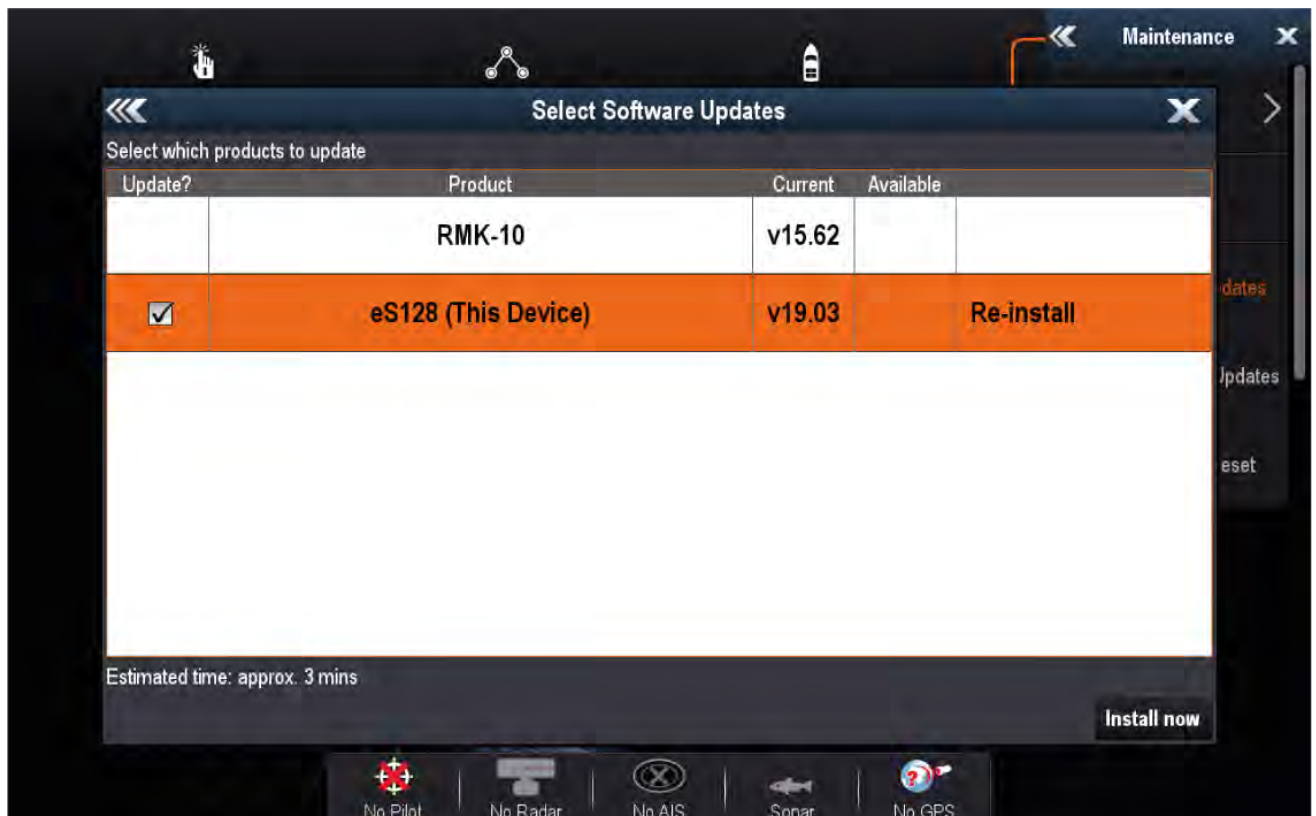

*When upgrading from LightHouse™ 2 to LightHouse™ 3 the Available software version column will remain blank and 'Re-install' is displayed. Select and hold on the Available column to confirm the version number of the software upgrade you are about to install and then select **Install**.*

iv. Select **Install now**.

The software upgrade procedure will commence. Please be patient and do not power off the MFD whilst the upgrade is in progress. During the upgrade process the MFD will re-boot. When complete your MFD will boot up with the new LightHouse™ 3 operating system.

8. Perform a Factory reset following the **Performing a settings or factory reset** procedure.
9. If applicable, update any Axiom™ MFDs so that the software version matches your upgraded eS or gS Series MFD.
10. If applicable, add any Axiom MFDs to your system or, add your upgraded eS or gS MFD to a system already containing Axiom™ MFDs.
11. If requested, select a Datamaster MFD and / or complete the Startup wizard.

In a mixed MFD network it is recommended that an Axiom™ MFD is selected as the Datamaster.

12. If applicable, restore your user data following the **Import user data** procedure.
13. Familiarise yourself with the new LightHouse™ 3 operating system by reviewing the LightHouse™ 3 operation instructions available from the website.

Saving all user data to a memory card

You can save all user data to one archive file.



With the Homescreen displayed:

1. Ensure you have a memory card (NOT a chart card) inserted into a card slot.
2. Select **My Data**.
3. Select **Import/Export**.
4. Select **Save Data**.
5. Select **Save All**.

The onscreen keyboard is displayed.

6. Using the keyboard, enter the filename you want to save the file as.
7. Select **SAVE**.

The select external storage dialog is displayed.

8. Select **SD1** (single or top card reader slot) or **SD2** (bottom card reader slot).
A confirmation dialog is displayed.
9. Select **OK**.

Copying media files

Recorded video and images stored in your MFD's internal storage can be copied to a MicroSD card.

With a MicroSD card inserted into your MFD's card reader slot:

From the **Homescreen**:

1. Select **My Files** from the **My Data** menu: (**Homescreen > My Data > My Files**).
2. Navigate to the required file by selecting folders to see its contents.
3. Highlight the file that you want to copy.
4. Select **Copy** from the File options.

*If you have more than one MicroSD card inserted, you will need to select which card to save the file to by selecting **SD1** or **SD2**.*

5. Select **Yes**.
The file will now be copied to your MicroSD card.
6. Once the file has copied, select **OK** in the confirmation dialog.
7. Repeat steps 2 to 5 above for each file that you want to copy.

Performing a settings or factory reset

Performing a **Factory reset** will erase ALL user data and reset the display's settings to their Factory default values. Performing a **Settings reset** will restore your display's settings to factory defaults, whilst retaining user data.

1. Select **Settings reset**, from the **This display** menu: **Homescreen > Settings > This display > Settings reset** to perform a settings reset.
2. Select **Factory reset**, from the **This display** menu: **Homescreen > Settings > This display > Factory reset** to perform a factory reset.

Importing user data

You can import user data (i.e.: Waypoints, Routes and Tracks) to your MFD.

1. Insert the MicroSD card that contains your user data files into a card reader slot on your MFD or connected card reader.
2. Select **Import from card** from the Import/export page: (**Homescreen > My data > Import/export > Import from card**).
3. Select the relevant SD card slot from the file browser and then navigate to your User data file (.gpx).
4. Select the relevant GPX file.
Your user data has now been imported.
5. Select **OK**.

Index

A

Activate Touchlock	42
ActiveCaptain	163
Adjust Locked heading.....	42
Advance waypoint.....	90
Aerial layer	162
AIS	
Enhanced symbols.....	138, 212
Enhanced symbols (targets).....	136, 213
Silent mode.....	58, 136, 214
Target list.....	210
Target status.....	138, 212
Target symbols	136, 211
Target tracking.....	210
AIS layer	162
AIS, Buddy.....	285
AIS, buddy list.....	133
AIS, target list	133
AIS, Target tracking.....	132
Alarm manager.....	69
Alarms	68
Acknowledgement.....	73
Active.....	69
AIS safety messages.....	72
Anchor drift.....	72
AX8 camera.....	73
Cross track error (XTE).....	72
Dangerous	68
Dangerous AIS targets.....	71
Dangerous Radar targets.....	71
Deep water arrival	72
Digital switching.....	73–74
DSC.....	72
Engine.....	73
External speaker	73
Fishing range	72
Guard zone 1.....	71
Guard zone 2	71
History.....	70
Lost Radar targets.....	71
Low fuel	72
MOB data type.....	72
Off track	72
Settings.....	71
Shallow water arrival.....	72
Warning	68
Water temperature.....	72
Waypoint arrival	71
Animated weather	172
App launcher.....	326
App pages	
Creating	55
Customizing.....	55
Applications.....	53
Apps	53
LightHouse	24
MFD	24
AR200	290
Calibration.....	290
Audio app.....	300
app controls.....	296

Balance.....	303
Crossover	303
Diagnostics mode.....	304
Fade.....	303
Menu options.....	302
Multi-zone	304
Multi-zone control.....	304
Opening.....	298
Player controls	296
Reset.....	304
Settings.....	303
Source	300
Zones.....	300
Audio controls	296
Audio receiver	294
Augmented Reality	274
AIS targets	286
AR200 setup.....	279
Camera installation and setup	275
Cartography source	286
ClearCruise settings	286
Compass bar.....	286
Flags	282–283
Goto flag.....	285
Range limit.....	286–287
Roll correction.....	288
Troubleshooting	351
Waypoints	286
Augmented Reality, camera FOV	276
Augmented Reality, Overview.....	282
Auto acquisition	
Data source requirements	214
Auto turn.....	92
Automatic linearization.....	291
Autopilot	
Adjust locked heading.....	42
Advanced settings.....	91
Control.....	88
Debug.....	92
Disengage	89–90
Engage or Disengage.....	42
Engaging.....	88
Pop-ups.....	91
Reset.....	92
Shortcuts.....	43
Sidebar	89
Standby.....	89
Status.....	90

B

Back up	
Settings.....	64
User data	64
Backup	
MFD settings.....	65
Routes.....	64
Tracks	64
Waypoints	64
Barbs	180
Battery.....	234
Battery data	234, 249
Battery selection.....	78
Bearing mode.....	240

Bird mode	207	Tide station	151
Blue Force	84, 139	Tides mode	109, 150
overview	139	Weather mode	109
SITREP	139	Chart app	
target symbols	136, 211	Laylines	122
Bluetooth		Chart detail	162
Audio	49, 331	Chart,	
Connection	330	Modes	109
Disabling	330	Cities layer	175
Enabling	330	ClearCruise	
pairing speaker	49, 331	Augmented Reality	277
Settings	330	Augmented Reality (AR)	274
Speaker volume	43, 331	Object detection	274, 279–280
Volume	42, 326	Coastal mode	207
Boat data	234, 248–249, 251	COG/SOG filter	60
Boat details	77	Collision avoidance	
Tanks		Course change	144, 146
Calibration	78–80	Enabling in the Chart app	142
Calibration points	79	Moving target	141
Boat Icon	77	Predicted Area of Danger zone	141
Boat name	77	Speed change	144, 147
Boat type	77	Stationary target	141
Brightness	42–43, 81	Color gain	191
Buddy, add to list from AR flag	285	Community edits	162
Buoy mode	207	Compass	
C		Alignment	92
Calibration	290	Linearization	290–291
iTC-5	39	Lock	92
Linearization	290	Offset	91
RealVision™ 3D	38	Restart	92
transducer	39	Compass lock	291–292
Calibration lock	92	Compass offset	291
Calibration, reset	291	Compatible entertainment systems	294–295
Camera		Compatible hardware	369
Tracking	112, 200	Connecting	
Cartography	161	RayControl	335
Chart		RayRemote	336
Boat position	166	RayView	337
ClearCruise	160	Connection	
Contours	163	NMEA 0183	84
Controls	107	Connections	
Current animation	150	Bluetooth	330
Current graph	153	Internet	329
Current station	152	Wi-Fi	329
Detailed mode	109	Contact details	358
Field of View (FOV)	161	Controls	
Find nearest	156	Chart	107
Fishing mode	109	Dashboard	232
Layers	111, 162	Fishfinder	184
Motion mode	166	Radar	198
Orientation	166–167	Video app	261
Race Start Line	128	Yamaha app	246
Race Start Line and Race Timer	127	CPA	221
Racing mode	109	Cross track error	113
Radar settings	135	Cruise speed	91
RealBathy	154	CSP (Commence Search Point)	115, 118
Search for objects	156	Current reading	291
Simple mode	109	D	
Sync view with other charts	166	Dangerous targets	135
Tide animation	150	Dashboard	
Tide bar	151	Controls	232
Tide graph	151	Data	234, 248, 250

Battery	249
Boat	234, 248–249, 251
Depth	234
Distance	235, 248, 250
Engine	235, 248, 250
Environmental	236, 248, 251
Fuel	236, 248, 250–251
GNSS (GPS)	236, 248–249
Heading	236, 249
Navigation	237, 250
Pilot	248, 250
Speed	237, 248, 250
Time	237, 250
Wind	238, 251
Data import and export	61
Data items	
Data overlays	27
Sidebar	27
Data master	81
Designation	81
Multiple	36
Selection	36
Data overlays	27
Data sources	37
Selection	37
Demo	
Movie	57
Profiles	57
Demo movie	
format	57
Depth	248, 250
Depth data	234, 248, 250
Depth offset	38
Deviation	291
Diagnostics	359
Product info	342
Digital switching	
Exporting pages	239
Importing pages	239
Disable all Sounders	42
Distance data	235, 248, 250
Dockside wizard	92
Document history	364
Documentation	20
Doppler	
Data source requirements	224
Overview	223
Downwind angle	77
Drive polarity	92
Drive type	91
Dual range	135

E

Easy View	162
Engage / Disengage autopilot	42
Engine connection wizard	78
Engine data	235, 248, 250
Engine identification wizard	37
Engine manufacturer	78
Engine quad display	78
Engine selection	78
Entertainment systems	294
Environment data	236, 248, 251

eS Series	374
Export	
Routes	64
Settings	64
Tracks	64
User data	64
Waypoints	64
External storage	
Inserting	46
Removal	47

F

Factory reset	343–344
File browser	64
First power up	35
Fishfinder	
Zoom mode	185
Fishfinder app	
App overview	184
Auto range	185
Channels	189
Controls	184
No source	187
No transducer	188
Range	185
Scroll back	190
Waypoints	189
Fishing range	164
Follow	113
FOV layer	162
Fuel data	236, 248, 250–251
Fuel manager	61
Set-up	63
Fusion	295

G

GNSS (GPS)	60
GNSS (GPS) data	236, 248–249
GNSS (GPS) Settings	60
GNSS/GPS troubleshooting	346
Goto waypoint	113
GPS	60
gpx	64
GRIBview	328
gS Series	374
Guard zone alarms	222
Gybe	93

H

Harbor mode	207
Hard over time	93
Heading data	236, 249
High res bathy	163
Homescreen	53

I

Import	
Settings	64
User data	64
Import tank calibration	80

Import/export.....	61
Initial setup	35
Internal GNSS (GPS)	60
Internet connection	329
IP address.....	359
IRPCS / COLREGS	140
iTC-5 calibration	39

J

JL Audio	295
----------------	-----

L

Languages.....	77
Selection.....	77
Laylines	122, 126–127
displaying and interpreting	125
enabling.....	124
Settings.....	124
system requirements	124
Wind shifts	126
LightHouse 3	
Compatible MFDs	20, 369
LightHouse™ 3	
Tips and Tricks	360
LightHouse 3 upgrade.....	374
Lighthouse third-party apps	
Install.....	328
LightHouse third-party apps	326
Background app	326
Downloadable.....	328
GRIBview	328
Lumishore	327
Mazu	327
Netflix.....	327
Preloaded	327
Seakeeper	327
Shadow-Caster	327
Spotify.....	327
Victron Energy	327
Limitations on Use	52
Limitations on Use (LoU).....	52
Linearization	290–291
Locked heading.....	88, 91
Lumishore.....	327

M

Magnetic deviation	290
magnetic interference	290
Man Overboard (MOB)	74
MARPA	
Data source requirements	214
Mazu.....	327
Media files	61
Memory cards	
Compatibility.....	44
Menus	
Settings.....	29, 75
Types	28
Messaging	61
MFD	

Buttons.....	32
Controls	32
MFD alarms	326
MFD settings	
Import.....	65
Restore	65
MicroSD	
Adaptor	45
Inserting.....	45–46
Removal	45–46
Miracast	85
MMSI.....	85
Mobile apps.....	334
Motor phasing	92
Multiple data sources (MDS).....	37
Mute	300
My data.....	61

N

N2K PGNs.....	362
Navigation data	237, 250
Navigation mode	88, 91
Navionics plotter sync	337
Netflix	327
New features	21
NMEA 0183	
Baud rate	84
Notifications.....	69

O

Object detection.....	279
ClearCruise settings	280
Offshore mode	207

P

Pairing	
Quantum radar.....	48
RMK keypad.....	48
PDF.....	64
PDF Viewer	
controls.....	309
Opening files	308
Overview.....	308
Searching a PDF	310
PGN support.....	362
Pilot data.....	248, 250
Pilot icon.....	88
Pilot sidebar.....	88
Point camera here	112, 200
Polar	77
Position.....	60
Power off	42
Power steering	92
Power troubleshooting.....	343
Powering off	34–35
Powering on	33–34
Primary MFD.....	81
Product information	359
Product support.....	358

R

Race Start Line	127
based on waypoints	128
creating	128
editing or deleting	130
Race Timer	127
starting	130
Radar	
Antenna size selection	206
Bearing alignment	206
Blank sectors	224
Color Gain	226
Comparison	200
Compatible scanners	203
Controls	198
Dual range	205
Features	200
Gain	225
MARPA	216
Modes	206
Overlay	167
Powering off	204
Rain	225
Range and Bearing	208
Sea	226
Selecting a scanner	205
Sensitivity controls	225
Settings	226
Standby	204
Stop transmitting	42
Target settings	218
Timed transmit	206
Radar Doppler	
Color palettes	223
Mode	223
Radar layer	162
Radar target	
Automatic acquisition	216–217
Cancel target	221
Cancel targets	218
Clear trails	220
Context menu	221
History	219
Information	221
List	217
Manual acquisition	216
Reference mode	218, 220
Relative mode	218
Shown CPA	221
Symbols	215
Tracking	214
Trails (Wakes)	220
True mode	218
Vectors	219
Radar troubleshooting	345
Radar without heading	136
Radar, target list	133
Range ring layer	162
RayControl	334–335
RayRemote	334, 336
RayView	334, 337
RealBathy	154, 165
Chart	155

Density	156
Height correction	156
RealBathy	155
Visibility	156
Waterline to tdc	156
RealVision 3D	
Controls	185
Waypoints	189
Receiver status	171
Recovery mode	343–344
Regulatory approvals	17
Responder	84
Settings	84
Rockford Fosgate	295
Route	98
Capacity	98
Creation	98
Follow	113
Importing	100
List	61, 100
Rudder	
Damping	92
Limit	92
Offset	92
Reverse reference	92
Rudder bar	90

S

Safe depth, minimum	78
Safe distance	135
Safe height, minimum	78
Safe width, minimum	78
Sail performance	77
SAR	114
creation	115, 118
pattern	114
Sector search pattern	114
SAR Pattern	
Drifts effects	116, 120
Save settings	65
Saving	
Product information	342
SBAS	60
Screen mirroring	85
Screen resolutions	83
Screenshot	43
Sea surface temperature	178
Seakeeper	327
Search and Rescue, <i>See</i> SAR	
Service Center	358
Settings menu	75
Regulatory approvals	17
Shadow-Caster	327
Shared brightness	81
Shortcuts menu	42
Sidebar	25
Pinning	26
Selection	26, 90
Simulator, <i>See</i> Demo	
SiriusXM	294
SiriusXM weather	170
Slew to Cue	112, 200
SmartStart	127

Software	
Compatible MFDs	20, 369
Software updates	47–48
Software version.....	20
Sonar	
Channel selection	186
Disable all sounders	42
Gain	191
History.....	190
Intensity	191
Noise filter.....	191
Sensitivity controls.....	191
Surface filter.....	191
TVG (Time Varied Gain)	192
Sonar logs	164
SonarChart Live	158, 164
Enabling.....	159
Tide correction.....	159
Speed data	237, 248, 250
Speed input	91
Splashscreen customization.....	82
Splashscreen reset.....	83
Splashscreen resolution	83
Sports fishing.....	163
Spotify	327
Startup wizard	36
Status area	58
Status area icons	58
Steer to Hdg.....	90
Steer to Nav.....	90
Stop Radar transmitting.....	42
Storm cast.....	177
Storm tracks	177
Support forum	360
Surface observation stations layer	175
Surface pressure	
Animated	173
Switching off.....	34–35
Switching on.....	33–34
System Datum	240

T

Take Screenshot	42
Tank calibration.....	78
Target tracking	132
Technical support.....	358, 360
Thermal camera	
Tracking	112, 200
third-party apps	
LightHouse third-party apps	326
Third-party apps	326
Tides layer	162
Tides mode	
Animation controls.....	150
Animation interval.....	167
Displaying graphs	154
Time data.....	237, 250
Time to Burn.....	127
Time/Date format.....	80, 239
Touchlock	43
Track with camera	112, 200
Tracking	
Thermal Camera	112, 200

Tracks	101
Capacity	101
Creation	102
Customize	103
Interval	103
List	61, 103
Trails clearing	220
Trails reset.....	220
Training courses	360
Transducer	
Configuration	38
Selection	38
Setup	38
Temperature calibration	38
Temperature settings.....	38
Trip	
Counter	61
Trip logs.....	61
Troubleshooting	342
Augmented Reality	351
Tutorials	20

U

UAV

App	319
App overview.....	312
Assuming control	324
Chart icon	159, 322
Chart integration.....	159, 322
Circle me.....	321
Compatible devices	313
Connection	315
Controller RC Cable.....	315
Controller signal lost.....	323
Controls	320
Critical battery.....	324
Disclaimer	312
Disconnect.....	321
Emergency procedures	323
Fish on	321
Flight.....	320
Flight data	313
Getting started	317
Goto	160, 323
Icon	160, 323
launching	320
Low battery	324
Manual control	324
No connection	318
No-fly zone.....	317
pre-requisites.....	314
Precautions	316
Record	312
Registration failed.....	319
Restricted airspace	317
Retrieval.....	321
Set up sequence.....	317
Settings.....	313
Screenshot page.....	317
Sport mode	313
Status area.....	313
Take off.....	320
Take photo.....	312

vectors	159, 322
Virtual joysticks	313
Uni-controller	
Functions	33
Units	80, 239
Unmute	300
Unpairing	
RMK keypad	48
Upgrading, software	47
Upwind angle	77
User data	61
Import	65
Restore	65
Back up	64
User interface	
Languages	77
User programmable button (UPB)	41

V

Variation	240
Vessel hull type	91
Victron Energy	327
Video	260
Feed selection	263
Renaming feeds	261
Video app	
Controls	261
Video app pages	260
Video Gallery	360
Video, viewing multiple inputs	260

W

Warranty	358
Watchbox alerts	181
Wave direction	
Animated	173
Wave height	
Animated	172
Wave period	
Animated	173
Waypoint	96
capacity	96
Goto	113
List	61
Placement	189
Waypoint, place from AR flag	285
Weather	
Settings	168
Weather data date	171
Weather layers	170
Weather mode	170, 207
Weather Radar	
Animated	172
Weather Radar layer	162
Wi-Fi	
Settings	329
Wind	
Data type	93
Shift	93
Wind arrows	180
Wind data	238, 251
Wind direction	180

Animated	172
Wind fields	177
Wind Radii	177
Wind speed	180
Wireless display	85

X

XTE,	
Restart	113

Y

Yamaha app	
Controls	246
Yamaha app	246, 248
Advanced	257
data items	248
Data page	249
Engine instances reset	257
Engine page	248, 251
Engine trim	255
Fuel flow offset	257
Gateway reset	257
Overview	246
Requirements	246
Settings	256
Status	
Engine warming up	254
Immobilizer lock	254
Synchronization	254
Status indicator	254
Tanks	255
Tanks page	251
Transmission	253
Trim Calibration	257
Troll mode	256
Warning	
Catalyst	255
Check engine warning	255
Low oil pressure	255
Low voltage	255
Overheat	255
Steering system	255
Water in fuel	255
Warning indicator	255



FLIR Belgium BVBA
Luxemburgstraat 2, 2321 Meer.
Belgium.

Tel: +44 (0)1329 246 700

www.raymarine.com

Raymarine[®]

a brand by  **FLIR**[®]