

Ray240 VHF Radio

with Digital
Selective Calling

Users Manual

Document # 81219_5

Date: July 2010

Trademarks and registered trademarks

Autohelm, hsb², RayTech Navigator, Sail Pilot, SeaTalk, SeaTalk^{NG}, SeaTalk^{HS} and Sportpilot are registered trademarks of Raymarine UK Limited. RayTalk, Seahawk, Smartpilot, Pathfinder and Raymarine are registered trademarks of Raymarine Holdings Limited.

All other product names are trademarks or registered trademarks of their respective owners.

www.raymarine.com

How to make an automatic Distress call

Step 1

Slide up cover

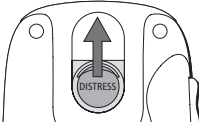

Step 2

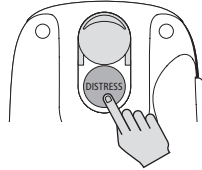

PRESS and HOLD for 5 SECONDS

Step 3



5 second countdown commences
Display backlight flashes

Step 4

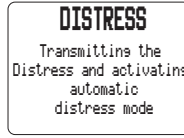

Step 5

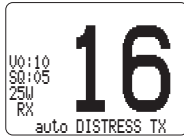

LISTEN



FOR ACKNOWLEDGEMENT

Step 6

Press and Hold PTT



THEN SPEAK



SLOWLY and CLEARLY

MAYDAY, MAYDAY, MAYDAY

This is.... (repeat name of vessel 3 times)

MAYDAY.... (name of vessel spoken once)

MY POSITION IS.... (latitude and longitude) or true bearing and distance from a known point).

IF YOU DON'T KNOW, DON'T GUESS.

I AM.... (sinking, on fire, etc)

I HAVE.... (number of persons on board and any other information - drifting, flares fired, etc)

I REQUIRE IMMEDIATE ASSISTANCE

OVER

RELEASE THE PTT SWITCH

How to make a Mayday call

Step 1

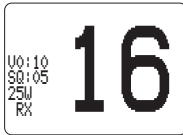

U0:10
S0:05
Z5U
RX

16

Step 2

Press and Hold PTT



THEN



SLOWLY and CLEARLY

MAYDAY, MAYDAY, MAYDAY

This is.... (name of vessel, spoken 3 times)

MAYDAY.... (name of vessel spoken once)

MY POSITION IS....(latitude and longitude. or true bearing and distance from a known point - IF YOU DON'T KNOW, DON'T GUESS).

I AM....(sinking, on fire, etc)

I HAVE.... (number of persons on board and any other information - drifting, flares fired, etc)

I REQUIRE IMMEDIATE ASSISTANCE

OVER

RELEASE THE PTT SWITCH
FOR ACKNOWLEDGEMENT AND INSTRUCTIONS

IF AN ACKNOWLEDGEMENT IS NOT RECEIVED
THEN REPEAT THE DISTRESS CALL

Step 3

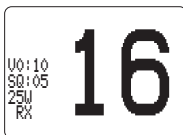

U0:10
S0:05
Z5U
RX

16

Contents

Important Information	3
Safety notices	3
Purpose	4
FCC Notice	4
EMC conformance	4
Declaration of conformity	5
Licensing requirements	5
Additional Information	6
Maritime Mobile Service Identity (MMSI)	6
Automatic Transmission Identification System	7
Waste Electrical and Electronic Equipment Directive	7
Handbook information	7
Warranty	7
Chapter 1: General Information	9
1.1 What is the Ray240?	9
1.2 What is DSC?	9
1.3 ATIS and Marcom-C mode	10
1.4 Can I use the Ray240 as part of an integrated system?	11
1.5 How do I use the Ray240?	12
Chapter 2: Operations	17
2.1 Introduction	17
2.2 The handset controls	17
....power the radio On and Off?	17
....adjust the handset volume?	17
....set the squelch?	18
....change channels?	18
....tune to the priority channel?	18
....get the weather forecast?	19
....select private channels?	19
....monitor channels?	19
....scan the channels?	20
....use the Memory?	20
....change the transmitting power?	20
....navigate the menus?	21
....use the Menu shortcuts?	22
....adjust the active speaker volume?	22
2.3 Using the handset - station control	23
2.4 Using the handset	24
....use the intercom?	24
....view phone book details?	24
....add an entry to the DSC phone book?	25

2.5	Using the handset - making and receiving DSC calls	26
make an individual routine call?	26
make a group routine call?	27
make a specified Distress call?	28
cancel a Distress call?	29
 receive a distress acknowledgement	30
 receive a distress call?	31
make an All Ships Safety call?	32
	How do I	33
make an All Ships Urgency call?	33
make a position request?	34
respond to a position request?	35
 access the DSC call log?	35
delete an entry from the DSC call log?	36
2.6	Receiving weather alerts	36
2.7	Additional functions	36
	Intercom	37
	Fog warnings	37
set up the automatic fog signal?	38
	Hailer	38
	Radio Sensitivity	39
	Handset Settings	39
Chapter 3:	Installation	41
3.1	EMC Installation Guidelines	41
3.2	What's in the box?	42
3.3	Where should I install my radio?	43
3.4	Typical installation	46
3.5	How much space does the Ray240 need?	47
3.6	How do I make the electrical connections?	49
3.7	How do I get position data?	51
3.8	Setting up the Ray240	52
 enter my boat's MMSI number?	52
enter my ATIS number?	53
Chapter 4:	Maintenance and Troubleshooting	55
4.1	Introduction	55
4.2	What maintenance can I do?	55
4.3	How do I troubleshoot the Ray240?	55
4.4	How do I get technical support?	56
Appendix 5:	VHF Channels	57
Appendix 6:	Technical specification	71
Appendix 7:	Hints and Tips	73
Appendix 8:	List Of Abbreviations	75

Important Information

Safety notices



WARNING

Electrical safety

Make sure the power supply is switched off before you make any electrical connections.



WARNING

Electromagnetic exposure

Failure to observe the Antenna and EME Exposure guidelines may expose those within the Maximum Permissible Exposure radius to RF radiation absorption that exceeds the FCC MPE limit. It is the Radio Operator's responsibility to ensure that no one is within this radius before transmitting.



WARNING

Navigation aid

Although we have designed this product to be accurate and reliable, many factors can affect its performance. As a result, it should only be used as an aid to navigation and never replace common sense and navigational judgement. Always maintain a permanent watch so you can respond to situations as they develop.



CAUTION

Compass safe distance

The compass safe distance for any part of the Ray240 installation including transceiver, handset and speaker, measured in accordance with EN 60945, for the Ray240 is 0.9 m.

Purpose

This handbook contains important information on the installation, operation and maintenance of the US and European versions of the Ray240 VHF radio, which is intended for light marine use and covers the following models:

- E42001 Ray240 System - US and Canadian version.
- E42002 Ray240E System - European version.

To get the best results in operation and performance, please take the time to read this handbook thoroughly.

FCC Notice

This device complies with Part 15 of the FCC Rules. Operation is subject to the following conditions:

- 1.This device may not cause harmful interference.
- 2.This device must accept any interference received, including interference that may cause undesired operation.

Changes or modifications to this equipment, not expressly approved in writing by Raymarine Inc., could violate compliance with FCC rules and void the operator's authority to operate the equipment.

EMC conformance

All Raymarine equipment and accessories are designed to the best industry standards for use in the recreational marine environment. Their design and manufacture conforms to the appropriate Electromagnetic Compatibility (EMC) standards, but correct installation is required to ensure that performance is not compromised.

Antenna mounting and EME exposure

Ensure that the antenna is connected to the radio before transmitting.

Raymarine declares a Maximum Permissible Exposure (MPE) radius of 1.5 meters (per OET Bulletin 65) for this system, assuming 25 watts output to an omnidirectional antenna of 3dBi gain or less.

For watercraft with suitable structures, the antenna base must be at least 3.5 meters above the main deck to meet the MPE for persons up to 2 meters tall. For watercraft without such structures, the antenna must be mounted so that its base is a minimum of 1.5 meters vertically from the heads of all persons.

Do not transmit when anyone is within the MPE radius of the antenna, unless they are shielded from the antenna field by a grounded metallic barrier.

Declaration of conformity

Raymarine UK Limited hereby declare that the products to which this handbook relates comply with the appropriate requirements and provisions of the R&TTE Directive 1999/5/EC.

The full Declaration of Conformity may be viewed on the relevant product pages at www.raymarine.com

Licensing requirements

United States

An Operator License is not required to operate a VHF Marine Radio within US territorial waters. However, a license is required to operate the radio if you dock in a foreign port (including Canada and Mexico) or leave a foreign port to dock in a US port. You can request a Restricted Radiotelephone Operator Permit from the Federal Communications Commission (FCC) by filing Form 753.

Canada

A license is not required to operate this radio within the sovereign waters of Canada. You will require a license to operate this radio outside of these waters. To obtain Industry Canada licensing information, contact the nearest field or regional office or write to:

Industry Canada
Radio Regulatory Branch
300 Slater Street
Ottawa
Ontario
Canada, K1A 0C8
Attention: DOSP

Europe

Regulations in some areas require that an Operator's license is obtained before operating a VHF radio. It is your responsibility to determine whether a license is required in your area before operating this equipment.

Additional Information

The following additional information will be required for completing a license application in Canada or the US:

Industry Canada Certification Number	IC: 4069B-RAY240D
FCC ID	PJ5RAY240
FCC Type Accepted	Parts 2, 15 and 80
Output Power	1 watt (low), 25 Watts (high)
Modulation	Frequency
Frequency Range	156.000 - 165.000 MHz

Maritime Mobile Service Identity (MMSI)

A nine-digit Maritime Mobile Service Identity (MMSI) number is required to operate the Digital Selective Calling (DSC) equipment in this radio.

United States

You can request an MMSI number from the FCC when you apply for a Station License. If your vessel does not require a license, you may obtain an MMSI by contacting either:

BoatUS (www.boatus.com), or
SeaTow (www.seatow.com).

Once obtained, you can program the MMSI number into your Ray240 using the Menu Operation described in this handbook.

Canada

You can obtain an MMSI number from your nearest Industry Canada Office.

Once obtained you can program the MMSI number into your Ray240 using the Menu Operation described in this handbook.

Europe

An MMSI number should be requested from the same agency that issues radio operator licenses in your area.

Once obtained, you can program the MMSI number into your Ray240 using the Menu Operation described in this handbook.

If regulations in your area do not permit you to program the MMSI number yourself, your Raymarine dealer can program the number for you.

For full details of programming your MMSI number into the Ray240 - see *Chapter 3: Installation*.

Automatic Transmission Identification System

Some European inland waterways require the use of the Automatic Transmission Identification System (ATIS). An ATIS number can be requested from the same agency that issues radio operator licenses in your area.

Waste Electrical and Electronic Equipment Directive



The Waste Electrical and Electronic Equipment (WEEE) Directive requires the recycling of waste electronic and electrical equipment. Whilst the WEEE Directive does not apply to some of Raymarine's products, we support its policy and ask you to be aware of how to dispose of this product.

The crossed out wheeled bin symbol, illustrated above, and found on our product signifies that the product should not be disposed of in general waste or landfill.

Please contact your local dealer, national distributor or Raymarine Technical Services for information on product disposal.

Handbook information

To the best of our knowledge, the information in this handbook was correct as it went to press. However, our policy of continuous product improvement and updating may change specifications without prior notice. As a result, unavoidable differences between the product and handbook may occur from time to time.

Raymarine cannot accept liability for any inaccuracies or omissions it may contain.

For the latest product information visit our website:

www.raymarine.com

Warranty

To register your new Raymarine product, please take a few minutes to fill out the warranty card. It is important that you complete the owner information and return the card to us to receive full warranty benefits.

Chapter 1: General Information

1.1 What is the Ray240?

The Ray240 is a combined VHF radio and Class D Digital Selective Calling (DSC) system, using a phone style handset to access and control all functions. It enables you to make digitally selected calls, which are quicker and simpler to make than traditional voice calls using Channel 16. It can transmit and receive on all available US, Canadian and International Marine VHF channels.

Should a distress situation occur, using the Ray240 you can quickly raise an alert, automatically indicating your identity and position, and establishing distress communication on the emergency voice channel.

1.2 What is DSC?

The present VHF radio system requires users to listen until someone speaks, and then determine whether the call is for them - more often than not, it isn't. DSC makes sure that you receive messages, and alerts you to the fact that it is for you.

DSC is part of the Global Maritime Distress and Safety System (GMDSS), a maritime communication system - not just for emergency and distress messages, but also for all types of existing ship-to-ship and ship-to-shore routine communications.

DSC is simply a tone signalling system, which operates on VHF Channel 70 and is similar to the tone dialling on your phone, but with the ability to include other information such as your boat's identification number, the purpose of the call, your position and the channel you want to speak on.

DSC calls can be divided into four categories:

- Calls to other ships.
- Group calls.
- Safety broadcasts.
- Distress alerts.

Calls to other ships and stations

To call another ship or a coast station, you simply enter their dedicated Maritime Mobile Service Identity (MMSI) number, select your chosen VHF working channel and send the call - it's like using a telephone. Both your radio and the one you are calling automatically switch to the chosen channel for conversation.

Group calls

When groups of ships need the same information (yacht races, club rallies etc.) a special group-call identity can be used to enable restricted broadcast messages.

Safety broadcasts

Safety broadcasts from coast stations and other shipping automatically generate an alert to ensure that this vital information is not missed.

Distress alerts

At the touch of a button, you can send your ships identity, your position and the nature of your distress. The position given will be precise and the alert will be heard immediately by all DSC equipped vessels and coast stations within range. The message is automatically repeated at approximately 4 minute intervals until it is acknowledged either by a coast station or a vessel within radio range.

Note: To transmit precise positions, the radio must be interfaced to your Global Positioning System (GPS). Otherwise, regular manual position updating is required.

1.3 ATIS and Marcom-C mode

ATIS is a European system used on some inland waterways. A VHF radio operating in an ATIS region must be programmed with a unique ATIS number; this can be obtained from the relevant licensing authority. The ATIS number is attached as a digital signal at the end of each transmission and identifies you to the relevant authorities who monitor the system.

When operating in ATIS mode, some of the Ray240 features are not available:

- Use of DSC is not permitted in ATIS regions. You will be unable to make DSC distress and other types of digital selective call.
- Dual / Tri Watch operation is not permitted in ATIS regions. You will be unable to use these features.
- Scan operation is not permitted in ATIS regions. You will be unable to use the scan features.
- ATIS regulations restrict the transmit power for certain channels. You will be unable to select the power on affected channels.

You can enable or disable ATIS using the menus (except on Marcom-C configured units).

Marcom-C mode is a restricted Ray240 configuration for VHF operators with a Marcom-C license. This is applicable to radios operated exclusively in European inland waterways using the ATIS system.

A Marcom-C VHF radio has the following restrictions:

- ATIS is permanently enabled. You will be unable to disable ATIS operation.

Marcom-C operation is set by the dealer at point of sale. If you wish to enable or disable Marcom-C mode, you must contact your Raymarine dealer.

For further information, please contact Raymarine technical support.

1.4 Can I use the Ray240 as part of an integrated system?

Your Ray240 can send and receive position information, e.g. latitude and longitude, using either of the following protocols:

- National Maritime Electronics Association (NMEA) 0183.
- SeaTalk

enabling DSC integration with other instruments.

Using these protocols enables your Ray240 to send position information to other instruments in your system whenever it receives:

- a response to a DSC position request.
- a DSC Distress call.

You can also add an additional handset and active speaker to the standard Ray240, giving two fully functional stations with an intercom function. This is particularly useful where your boat has dual helms or a second navigation station.

1.5 How do I use the Ray240?

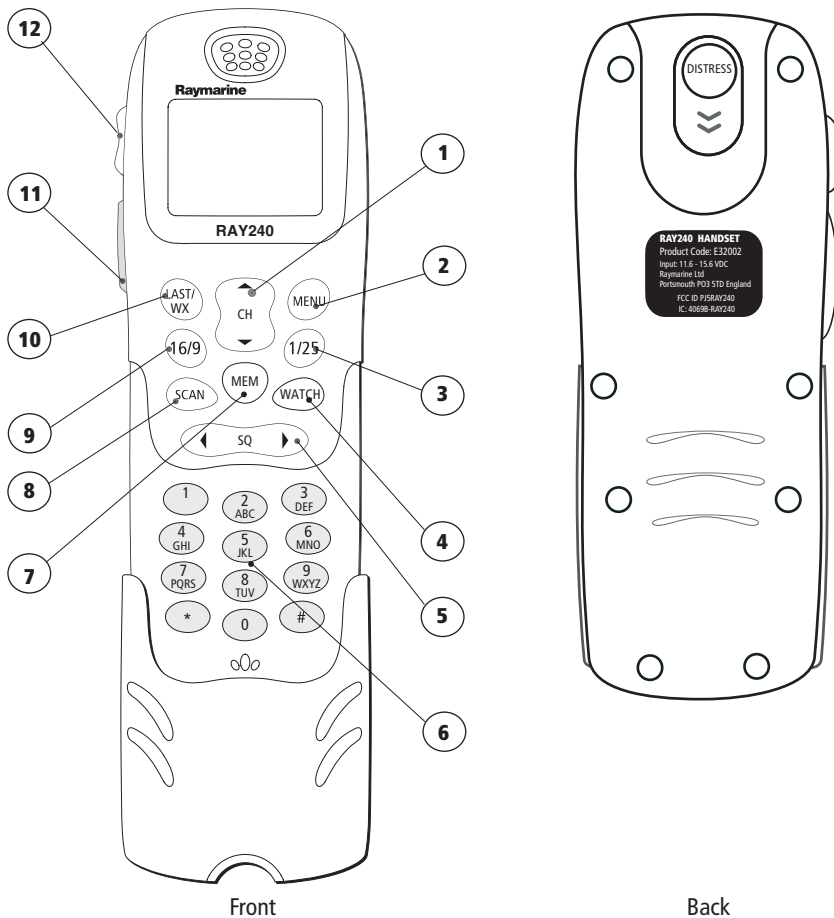

You can access all of the functions of the Ray240, with the exception of adjusting the active speaker volume, from the handset. The clearly marked buttons and alpha-numeric keypad make operation simple.

The **DISTRESS** button can be found beneath a sliding cover on the back of the handset. By simply sliding the cover up and pressing the button, the DSC Distress Call procedure is started.

- 1. CHANNEL UP/DOWN** moves the selected channel up or down, or scrolls through the menus.
 - 2. MENU** Press to access the menus, or to select a menu option. Press and hold to access the phone book.
 - 3. 1/25** changes the transmitting power setting from 1 watt (low) to 25 watt (high) or vice versa.
 - 4. WATCH** Press to activate the Dual Watch function (2 channels). Press and hold to activate the Tri-Watch function (3 channels).
 - 5. SQUELCH** mutes any background noise. Also used for the backspace function when making alpha-numeric entries.
 - 6. Key pad** The alpha-numeric keypad has multi-tap operation, the same as a mobile phone.
 - 7. MEMORY** commits a channel to the radio memory.
 - 8. SCAN** starts the scanning of available channels. Press to start priority scanning. Press and hold to start non-priority scanning.
 - 9. 16/9 (16)** Press to power up the radio. Press and hold for 5 seconds to power off the radio. When using the radio, press to re-tune to the priority channel.
 - 10. LAST/WX (PRIV)** Press to return to either the last selected channel, or when navigating the menus to return to the previous screen. Press and hold to access the Weather channels. (Press and hold to access private channels).
 - 11. Push to Talk** Press and hold to send a voice message. Release to return to receive mode.
- Note:** The maximum transmit time is limited to 5 minutes to prevent non-intentional transmissions from occupying the VHF channel.
- 12. Volume** adjusts the volume of the handset up or down.

Note: Differences for European versions of the radio are shown in brackets.

Which menu do I need?

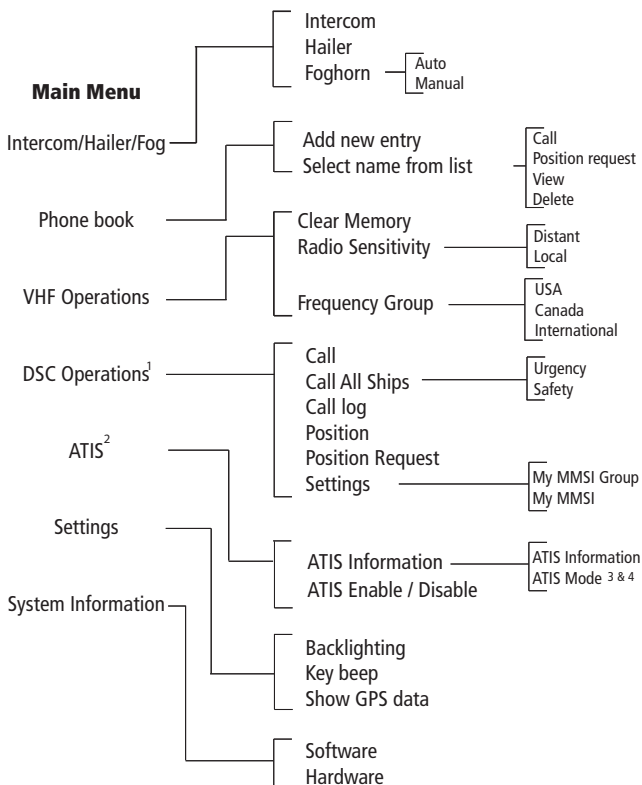

- Notes:**
- (1) A Maritime Mobile Service Identity (MMSI) number is required to operate DSC functions.
 - (2) ATIS function only available on European models. An Automatic Transmission Identification System (ATIS) number is required to operate. ATIS enable/disable is not applicable to units restricted to Marcom-C operation.
 - (3) ATIS Enabled - transmit power is limited to 1W on Channels 6, 8, 10, 11, 12, 13, 14, 15, 17, 71, 72, 74, 75, 76 and 77 in accordance with regulations for European Inland Waterways.
 - (4) ATIS Disabled - transmit power restrictions are disabled for use at sea. DO NOT use this mode when operating on European Inland Waterways.

What does the display tell me?

The liquid crystal display (LCD) screen will give you the following information depending on which screen you choose to display:

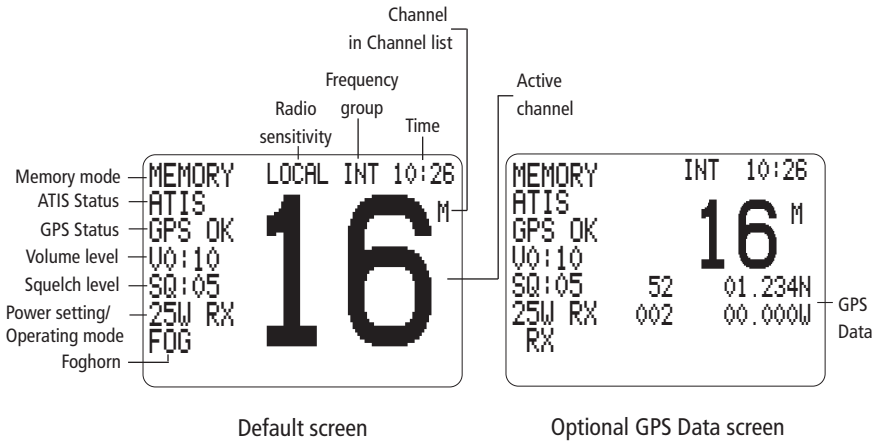

D8061_1

Memory mode

shows when available channels are selected from the memory.

ATIS Status

when shown indicates ATIS is active.

GPS Status

GPS OK - indicates position data available.
NO GPS - indicates no GPS data available.

Volume level

shows the current volume level. Adjustable from 0 to 10.

Squelch level

shows the current squelch level. Adjustable from 0 to 10.

Power setting

shows the power level. 1 Watt (low) or 25 Watts (high).

Operating mode

shows which operating mode the radio is in., transmit (TX) or receive (RX).

Radio sensitivity

shows when Local sensitivity level selected.

Foghorn

shows when automatic foghorn is running.

Frequency group

shows selected frequency group, USA, Canada or International.

Active channel

shows the channel on which the radio is currently operating.

GPS Data

when available shows current position.

Chapter 2: Operations

2.1 Introduction

This chapter shows you how to operate the controls of the Ray240 and use it to make the common Digital Selective Calling (DSC) calls.

Using the radio is simple. All of the functions, except adjusting the active speaker volume are controlled from the handset.

Note: Differences for the European versions of the radio are shown in brackets in the text.

2.2 The handset controls

How do I

....power the radio On and Off?



Power ON

PRESS the **16/9 (16)** button to turn on the radio.

Power OFF

PRESS and HOLD the **16/9 (16)** button for 2 seconds.

The radio enters low power standby mode.

In standby mode the Ray240 is inoperative and will not receive DSC calls, but your radio settings are retained.

To completely power down the Ray240, power must be switched off at the source.

....adjust the handset volume?



PRESS the volume key on the side of the handset to adjust the handset volume up or down. Each press of the key raises or lowers the volume by one level.

Note: It is not possible to adjust the volume while the radio is in 'Menu' mode.

How do I

....set the squelch?



Use squelch to stop background static noise from the receiver. Press the right arrow to increase the squelch and the left arrow to decrease it. The optimum squelch setting is obtained by turning the squelch down until background noise is heard. Then increase the setting by one level to stop this noise.

Note: It is not possible to adjust the squelch setting while the radio is in 'Menu' mode.

....change channels?



Channel UP/DOWN button

Press the Channel UP/DOWN button to change the channels sequentially.

OR



Keypad

By using the keypad you can directly select the required channel number. Pressing # selects the channel immediately. If you do not press # the channel is selected after 2 seconds.

....tune to the priority channel?



PRESS this button at anytime when using the radio to tune to the priority channel.

Note: EU models use button **16**.

How do I

....get the weather forecast?



PRESS and HOLD this button to access the Weather channels. Use the channel button to select W0 through to W9 depending upon which weather channel is required.

Note: This function is only available when US/Canadian frequency groups are selected.

....select private channels?



PRESS and HOLD this button to access the Private channels. Use the channel button to select the required Private channel.

Note: This function is only available when International frequency group is selected. Private channels are enabled by your Raymarine dealer.

...monitor channels?



Dual Watch (2 channels)

PRESS this button to start the Dual Watch function.

The radio keeps operating on the current channel, while monitoring the priority channel. If activity is detected on the priority channel it becomes active. When the priority channel is no longer active the radio resumes Dual Watch.

Tri-Watch (3 channels)

PRESS and HOLD this button to start the Tri-Watch function.

The radio will keep operating on the current channel, while monitoring the priority channel and the last channel. Activity detected on any of these channels will make it active. When that channel is no longer active the radio resumes Tri-Watch.

In both watch modes, removing the handset from the cradle halts the mode. You can transmit on the active channel. When the handset is replaced in the cradle the selected watch mode is resumed.

How do I

....scan the channels?



Non-priority scanning

PRESS this button for non-priority scanning. The radio will scan the channels in sequence for activity, automatically tuning to a channel if activity is detected.

Priority scanning

PRESS and HOLD this button to start priority scanning. The radio scans the priority channel in between scanning each channel in sequence. If activity is detected on a channel the radio automatically tunes to that channel.

Scan a channel list

PRESS this button with a memorized channel list operative and only those channels contained in the list will be scanned.

In both scan modes, removing the handset from the cradle halts the mode. You can transmit on the active channel. When the handset is replaced in the cradle the selected scan mode is resumed.

....use the Memory?



Create a channel list

To create a channel list, select the first channel required, PRESS and hold this button.

PRESS and hold again to remove a channel from the list.

Use a channel list

When you have created a channel list, PRESS this button, you can now select channels from your channel list.

....change the transmitting power?



PRESS this button to change the transmitting power of the radio from 1 Watt (Low) to 25 Watt (High) and vice versa.

How do I ...navigate the menus?



MENU

PRESS this button to access the menus or to accept a menu option.



CHANNEL UP/DOWN

PRESS this button to scroll through the menu options.



LAST/WX (PRIV)

PRESS this button to return to the previous screen.
PRESS and hold to exit the Menu.

Note: EU models use button **LAST/PRIV**.



16/9 (16)

PRESS this button to return to the priority channel.

Note: EU models use button **16**.

How do I

....use the Menu shortcuts?



Press and hold to access the DSC Phone Book. For further information refer to - How do I*make an individual routine call?* on *page 26*



PRESS to move the cursor bar to the last item on the current display. If the cursor is on the last item, the next page, if available, is shown.
PRESS and HOLD to move the cursor bar to the last item in the menu.



PRESS to move the cursor bar to the top item on the current display. If the cursor is on the top item, the previous page, if available, is shown.
PRESS and HOLD to move the cursor bar to the first item in the selected menu.

....adjust the active speaker volume?



Turn the active speaker knob clockwise to turn the speaker on and increase the volume.
Turn the knob counter-clockwise to decrease the volume and turn the speaker off.

2.3 Using the handset - station control

Note: Applicable to installations with 2 handsets.

In normal operation an installation with 2 stations has a primary and a secondary station. The primary station can access all menu functions, the secondary station has limited functionality. Station control enables the user to designate either station as the 'primary' station, utilizing full functionality.

When the Ray 240 is powered, no station has control. To take station control, one of the following must be carried out:

- taking the handset from the cradle.
If the handset was out of the cradle at power-up it must be replaced in the cradle and then removed.
- pressing a handset button - the handset can be in or out of the cradle.
- pressing the PTT switch - the handset must be out of the cradle.

If you want to change the station in control, lift the handset of the other station, the Station Control menu is displayed.

STEP 1

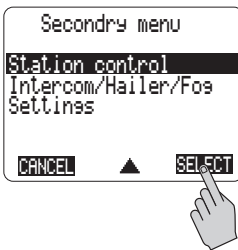

STEP 2



STEP 3

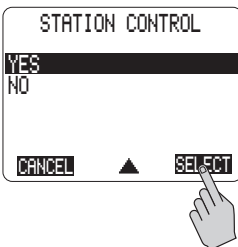

You now have station control the following screen appears on the other handset



Note: If the Ray240 is in standby mode, the handset used to activate the radio becomes the handset with station control.

2.4 Using the handset

How do I

....use the intercom?

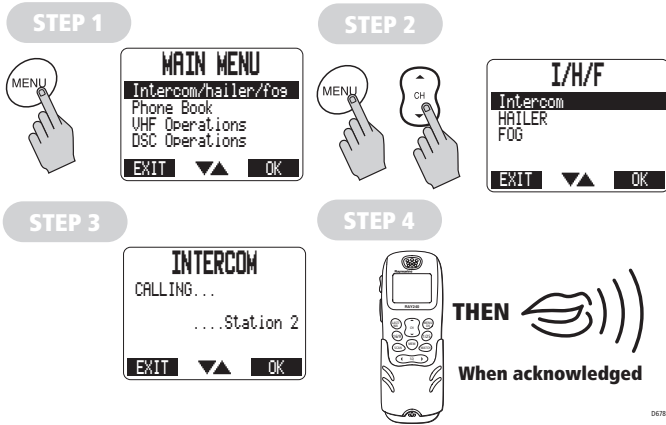

Note: The intercom function is only available when a second station is installed.

....view phone book details?

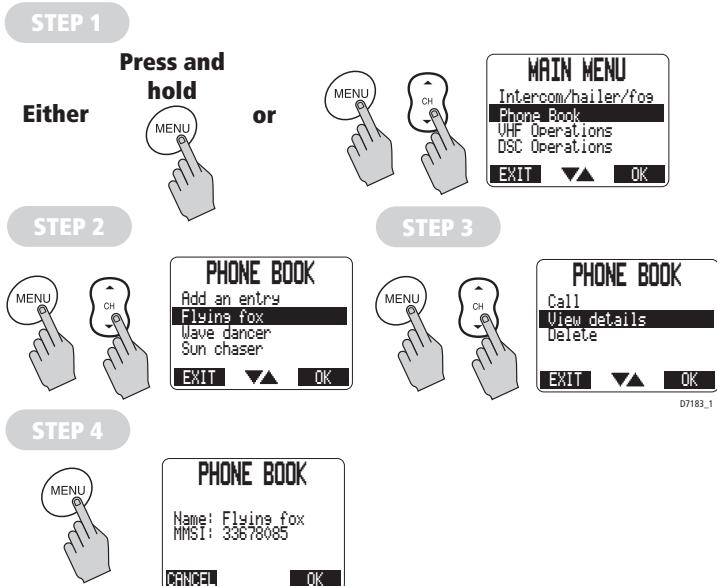

How do I

....add an entry to the DSC phone book?

STEP 1



STEP 2



STEP 3



STEP 4



STEP 5

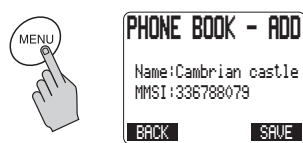

STEP 6



- Notes:**
- (1) Boat names are limited to 15 characters.
 - (2) MMSI numbers can be entered as boat, group or shore numbers.
 - (3) Group MMSI numbers always start with a zero.

2.5 Using the handset - making and receiving DSC calls

How do I

....make an individual routine call?

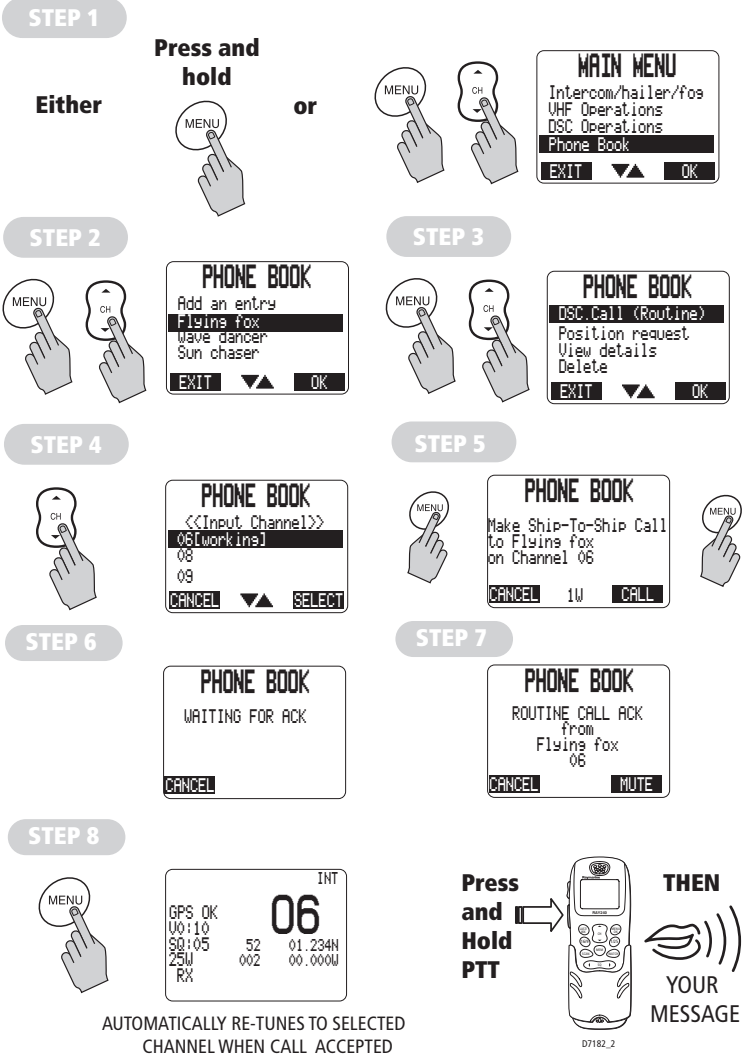

Note: Ship-to-ship individual routine call shown. If call is made to a shore station they decide on the channel for communication.

How do I

....make a group routine call?

STEP 1



STEP 2



STEP 3



STEP 4



STEP 5



STEP 6



STEP 8

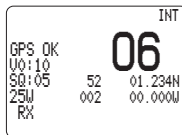

AUTOMATICALLY RE-TUNES TO SELECTED CHANNEL

Press and Hold PTT



THEN

YOUR MESSAGE

D7182_2

How do I

....make a specified Distress call?

STEP 1



STEP 2

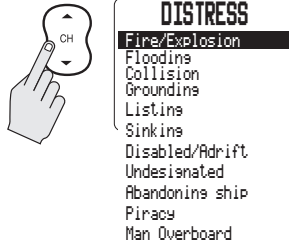

STEP 3

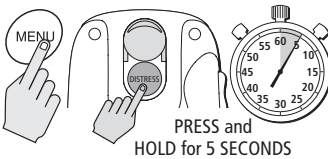

STEP 4

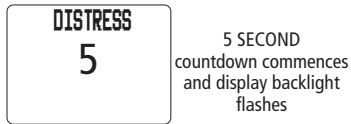

STEP 5

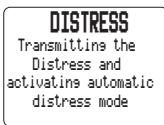

MAYDAY, MAYDAY, MAYDAY

This is.... (repeat name of vessel 3 times)

MAYDAY.... (name of vessel spoken once)

MY POSITION IS.... (latitude and longitude) or true bearing and distance from a known point).

IF YOU DON'T KNOW, DON'T GUESS.

I AM.... (sinking, on fire, etc)

I HAVE.... (number of persons on board and any other information - drifting, flares fired, etc)

I REQUIRE IMMEDIATE ASSISTANCE OVER

STEP 6

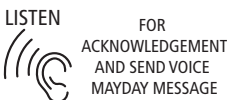
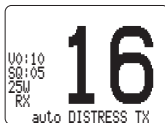

RELEASE THE PTT SWITCH

How do I

....cancel a Distress call?

Note: The 'Distress' option on the main menu is only available after a DSC distress call has been sent.

STEP 1

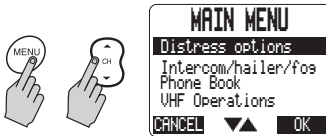

STEP 2

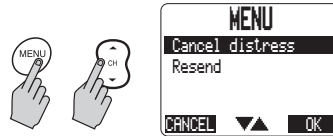

STEP 3

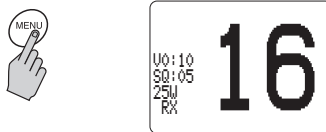

STEP 4

**Press
and
Hold
PTT**



THEN

ALL STATIONS, ALL STATIONS, ALL STATIONS

THIS IS.. (MMSI number and Vessel name or
Call sign spoken 3 times)

DISTRESS ALERT SENT....(time and date)
IS CANCELLED



OVER

SLOWLY and CLEARLY

How do I

.... receive a distress acknowledgement

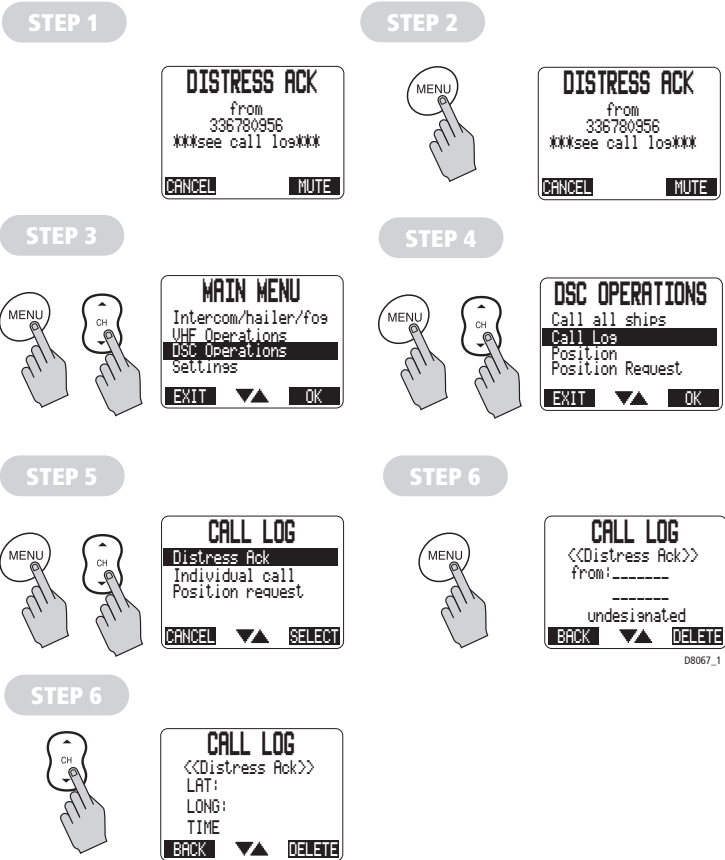

How do I

.... receive a distress call?

An incoming DSC distress call will cause an audible alarm to sound and the display to flash. After 10 seconds the alarm volume rises to maximum unless muted by pressing the MUTE button.

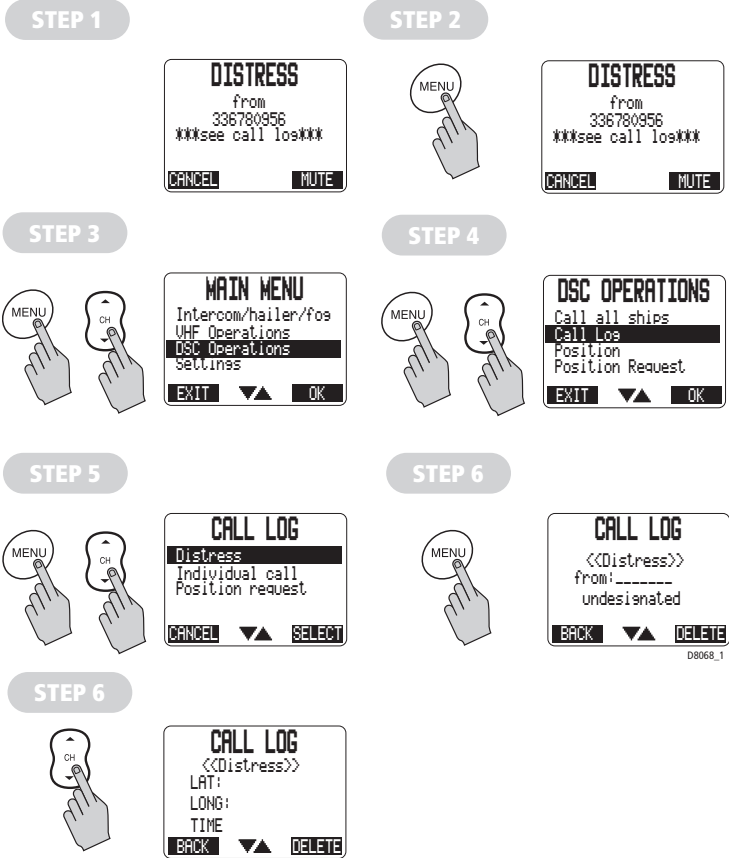

Note: The Call log will contain the name, time and position of the boat in distress.

How do I

....make an All Ships Safety call?

STEP 1

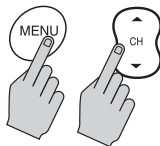

STEP 2

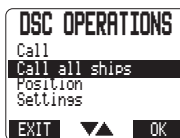

STEP 3



STEP 4



Call sending acknowledged
Radio retunes to Channel 16

STEP 5

Press
and
Hold
PTT

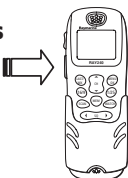

THEN



SLOWLY and CLEARLY

PAN PAN, PAN PAN, PAN PAN

ALL STATIONS or individual Coast Guard Station (spoken 3 times)

THIS IS.. (MMSI number and Vessel name or Call sign spoken 3 times)

MY POSITION IS.... (latitude and longitude) or true bearing and distance from a known point).
IF YOU DON'T KNOW, DON'T GUESS.

SHIPPING SHOULD BE AWARE OF
(submerged container)

OVER

How do I

....make an All Ships Urgency call?

STEP 1

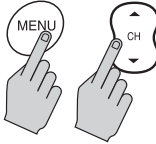

STEP 2

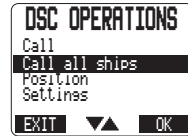

STEP 3



STEP 4



Call sending acknowledged
Radio retunes to Channel 16

STEP 5

Press
and
Hold
PTT



THEN



SLOWLY and CLEARLY

PAN PAN, PAN PAN, PAN PAN

ALL STATIONS or individual Coast Guard Station (spoken 3 times)

THIS IS.. (MMSI number and Vessel name or Call sign spoken 3 times)

MY POSITION IS.... (latitude and longitude) or true bearing and distance from a known point).
IF YOU DON'T KNOW, DON'T GUESS.

I HAVE... (lost power and am drifting)

I REQUIRE (state type of assistance required e.g. a tow urgently.)

OVER

How do Imake a position request?

STEP 1

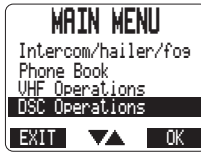
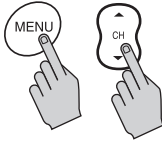

STEP 2

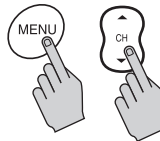

STEP 3

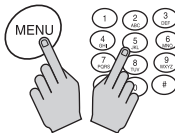

STEP 4



STEP 5



STEP 6

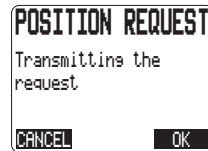

STEP 7

Re-tunes to
working
channel



How do I

....respond to a position request?

STEP 1



STEP 2



D7185_2

STEP 7

Re-tunes to
working
channel

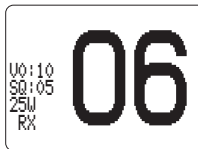

.... access the DSC call log?

STEP 1

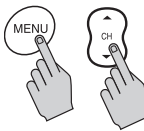

STEP 2

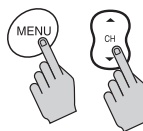

STEP 3

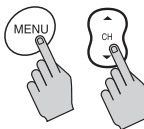

STEP 4



D7202_2

- Notes:**
- (1) A maximum of 20 calls can be stored in the call log.
 - (2) Calls are stored as they are received. If the call log is full then the oldest entry will be discarded.
 - (3) A message is displayed on the screen if there are unread DSC calls in the call log. Unread calls are prefixed with an asterisk (*) in the call log.

How do I

....delete an entry from the DSC call log?

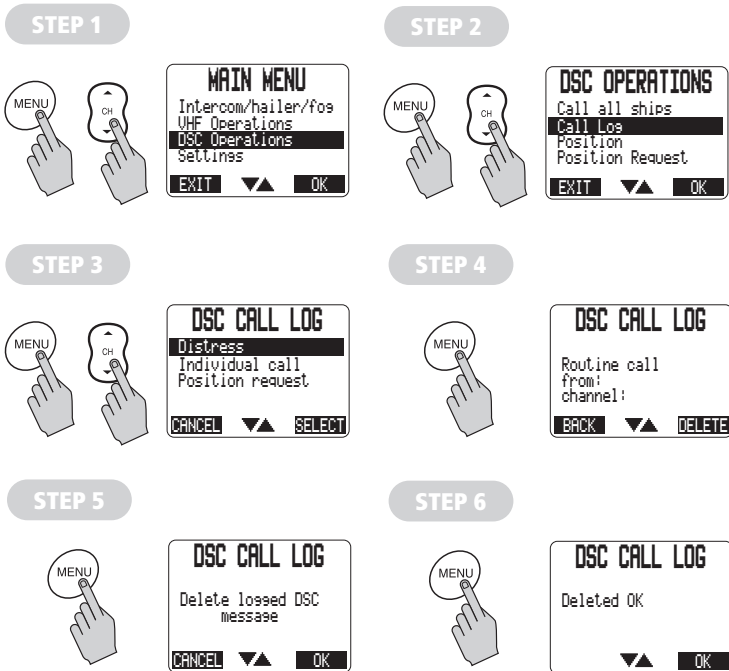

07203_1

2.6 Receiving weather alerts

Note: Applies to Ray240, not Ray240E models.

Whilst the radio is in Dual or Tri-Watch modes, and a National Oceanographic and Atmospheric Administration (NOAA) weather channel has been selected, when a weather alert is received the radio will sound an audible alarm and automatically switch to the monitored weather channel so that the emergency broadcast can be heard.

2.7 Additional functions

In addition to those already described in this chapter, the Ray240 has further functions that can be accessed from the Main menus.

This section gives a brief description of these functions and what they do.

Intercom/fog/hailer

Intercom

for full details of using the intercom function refer to How do I....*use the intercom?* on *page 24*.

Fog warnings

The Ray240 has in-built fog warning tones that can be transmitted through a hailer horn. These tones can be used in manual or automatic modes, but any volume adjustments will need to be made in manual mode before selecting automatic mode.

Manual mode

In manual mode a tone is transmitted whenever the PTT switch is pressed. Releasing the PTT will stop the tone.

Automatic mode

In automatic mode a signal is generated and transmitted by the unit at preset intervals not exceeding 2 minutes until cancelled. The available tones are:

Signal	Tone
Power boat Underway and making way	1 long tone
Powerboat Underway and not making way	2 long tones
Sailboat under sail Any type of boat that is: Fishing Not under command Restricted ability to maneuver Constrained by draught Towing	1 long, 2 short tones
Under tow	1 long, 3 short tones
Pilot	4 short tones
Boat at anchor (less than 100m in length)	1 short, 1 long, 1 short tone

How do I

....set up the automatic fog signal?

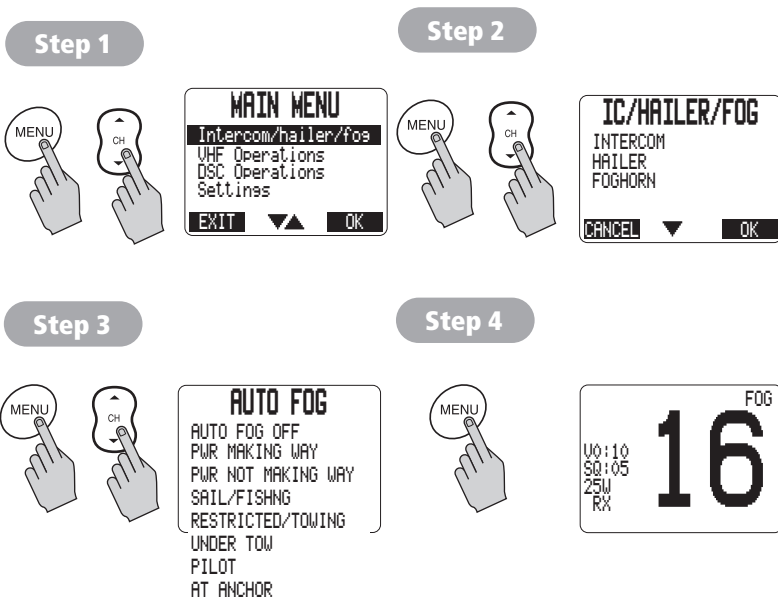

D7174_1

Hailer

The hailer can be used to both listen and talk.

Listen

With the hailer in listen mode, you can change the level of the listening volume in the handset ear piece by using the handset volume button. The volume can be adjusted at the active speaker by using the active speaker volume control.

Talk

To use the hailer in talk mode, just press and hold the PTT. The volume of the hailer can be adjusted by using the volume button when the PTT switch is pressed.

VHF Settings

Radio Sensitivity

Enables the receiving sensitivity of the Ray240 to be reduced in areas of high traffic to decrease unwanted reception. This is also known as local mode.

Settings

Handset Settings

Enables you to adjust the following:

- Keypad backlighting
- Keypad clicks
- Show GPS data

Chapter 3: Installation

3.1 EMC Installation Guidelines

All Raymarine Equipment and accessories are designed to the best industry standards for use in the recreational marine environment.

Their design and manufacture conforms to the appropriate Electromagnetic Compatibility (EMC) standards, but correct installation is required to ensure that performance is not compromised. Although every effort has been taken to ensure that they will perform under all conditions, it is important to understand what factors could affect the operation of the product.

The guidelines given here describe the conditions for optimum EMC performance, but it is recognized that it may not be possible to meet all of these conditions in all situations. To ensure the best possible conditions for EMC performance within the constraints imposed by any location, always ensure the maximum separation possible between different items of electrical equipment.

For optimum EMC performance, it is recommended that wherever possible:

- Raymarine equipment and cables connected to it are:
 - At least 3 ft. (1m) from any other equipment transmitting or carrying radio signals. In the case of Single Side Band (SSB) radio, the distance should be increased to 7 ft. (2m).
 - More than 7 ft. (2m) from the path of a radar beam. A radar beam can normally be assumed to spread 20 degrees above and below the radiating element.
- The equipment is supplied from a separate battery to that used for engine start. Voltage drops below 10 V, and starter motor transients, can cause the equipment to reset. This will not damage the equipment, but may cause the loss of some information and may change the operating mode.
- Raymarine specified cables are used. Cutting and rejoining these cables can compromise EMC performance and must be avoided unless doing so is detailed in the installation manual.

Suppression Ferrite

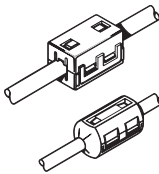

If a suppression ferrite is attached to a cable, this ferrite should not be removed. If the ferrite needs to be removed during installation it must be reassembled in the same position.

The illustration shows typical cable suppression ferrites used with Raymarine equipment. Always use the ferrites supplied by Raymarine.

07166.1

Connections to other equipment

If your Raymarine equipment is to be connected to other equipment using a cable not supplied by Raymarine, a suppression ferrite **MUST** always be attached to the cable near to the Raymarine unit.

3.2 What's in the box?

You will find these items in the box:

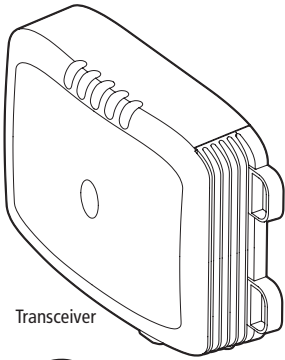

Transceiver

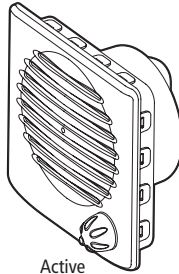

Active speaker

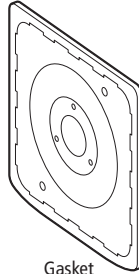

Gasket set

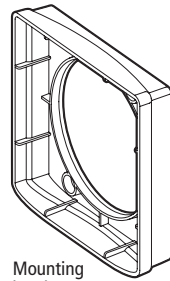

Mounting bracket



5 m extension cable

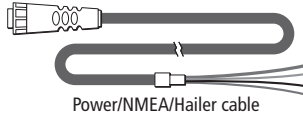

Power/NMEA/Hailer cable



Dust cover



Quick reference guide

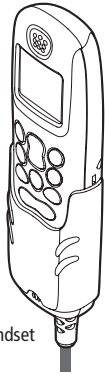

Handset

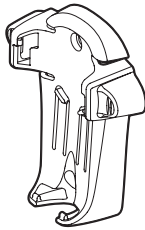

Handset Cradle



Connector plate



Stud (x2)



Thumb nut (x2)



Screw, No.8 x 3/4" (x6)



Screw, No.4 x 3/8" (x3)



Handbook

01711.1

Can I get optional extras?

You can obtain the following optional extras for the Ray240:

Description	Part No.
Second station includes handset, cradle and active speaker and 5m extension cable	E45001
Ray240	E45002
Ray240E	
Handset only	
Ray240	E45009
Ray240E	E45010
Active speaker	E45003
Hailer horn	M95435
Extension cable, 3m	E45011
Extension cable, 5m	E45012
Extension cable, 10m	E45013
Bulkhead Mounting Kit	E45014
Bracket (trunnion) Mounting Kit	E25009

3.3 Where should I install my radio?



CAUTION

Compass safe distance

The compass safe distance for any part of the Ray240 installation including transceiver, handset and speaker, measured in accordance with EN 60945, for the Ray240 is 0.9 m.

Before installing the Ray240 you should plan the installation, considering the following points:

Transceiver Unit

You should mount the transceiver unit on a bulkhead, below decks that is:

- dry, protected and well ventilated.
- free from high operating temperatures.
- free from excessive vibration.
- accessible for cable routing.
- at least three feet from the antenna.
- in such a position that accidental contact with the heatsink is avoided.

You must avoid mounting it:

- in an engine compartment.
- where there might be flammable vapors, such as in an engine room or compartment, or in a fuel tank bay.
- where there is water splash or spray from bilges and hatches.
- where it is a risk of physical damage from heavy items, such as hatch covers, tool boxes, etc.
- where it might be covered by any other equipment.

Handset and cradle

You should mount the primary handset and cradle:

- where they are easily accessed from the location where the ship is normally navigated. Federal Communications Commission (FCC) law requires that the primary handset is located in the wheelhouse or a room adjacent to it.
- at least three feet from the antenna.

Active speaker

You should mount the active speaker in a position where it is easy to hear and is convenient for your use.

Antenna (not supplied)

You should use a good quality VHF antenna, designed for marine use installed in accordance with the following:

- ensure that the antenna is connected to the radio before transmitting.
- Raymarine declares a Maximum Permissible Exposure (MPE) radius of 1.5 meters (per OET Bulletin 65) for this system, assuming 25 watts output to an omnidirectional antenna of 3dBi gain or less.
- for watercraft with suitable structures, the antenna base must be at least 3.5 meters above the main deck to meet the MPE for persons up to 2 meters tall.
- for watercraft without such structures, the antenna must be mounted so that its base is a minimum of 1.5 meters vertically from the heads of all persons.

- as high as possible and free from obstruction for maximum range. VHF transmission is essentially line-of-sight.
- if you have to extend the length of the co-axial cable between the antenna and the radio, use one that is designed for minimum power loss over the cable length.

Cables

When planning the installation, consideration should be given to where cables are to be run:

- Try and avoid acute bends in cables.
- Secure and protect cables from physical damage and protect them from exposure to heat. Avoid running cable through bilges or doorways, or close to moving or hot objects.
- Where a cable passes through an exposed bulkhead or deck head, a water-tight feed-through should be used.

3.4 Typical installation

A typical installation for the Ray 240 is shown below:

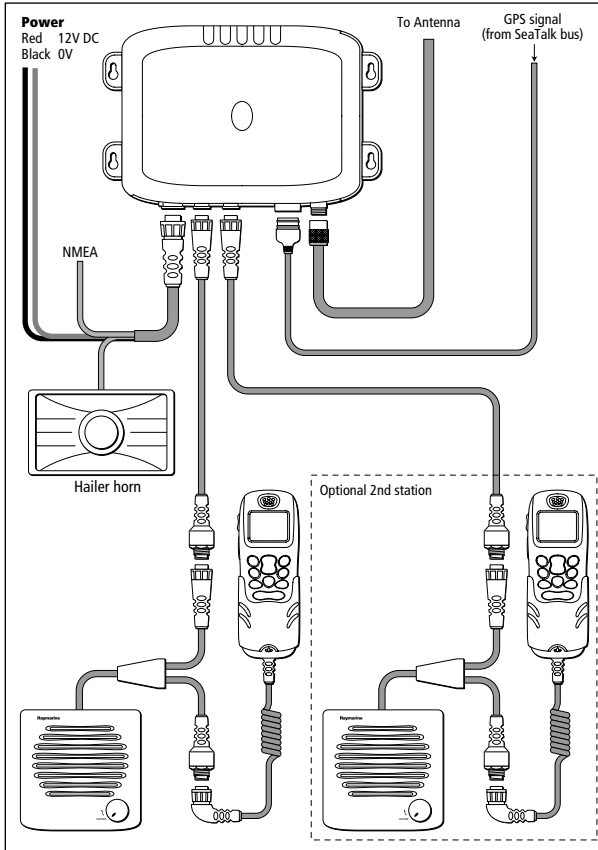

Note: If you wish to connect your SeaTalk GPS antenna (e.g. RS125) directly to the Ray240 VHF you must ensure that the GPS antenna is also connected to a suitable power supply.

3.5 How much space does the Ray240 need?

To help you plan the installation of your Ray240 and its associated components the dimensions are:

Transceiver Unit

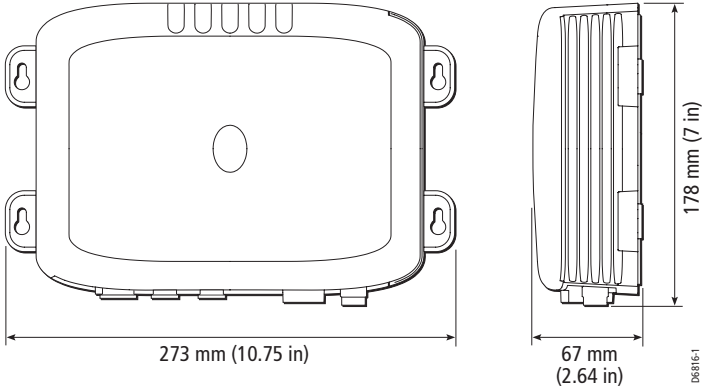

A 50mm air space should be left around the transceiver when installed to enable airflow and ventilation for cooling the heatsink.

Note: During normal operation, the transceiver unit heat sink will become warm. This does not affect the operation of the unit.

Active speaker

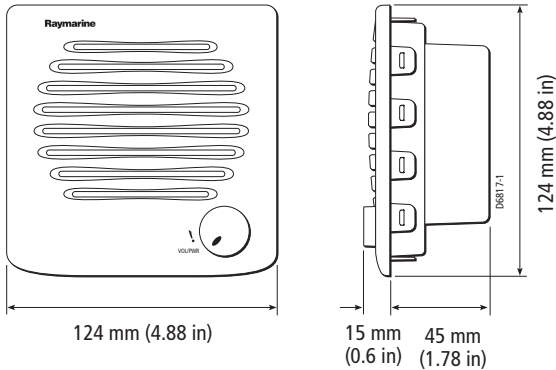

Handset and Cradle

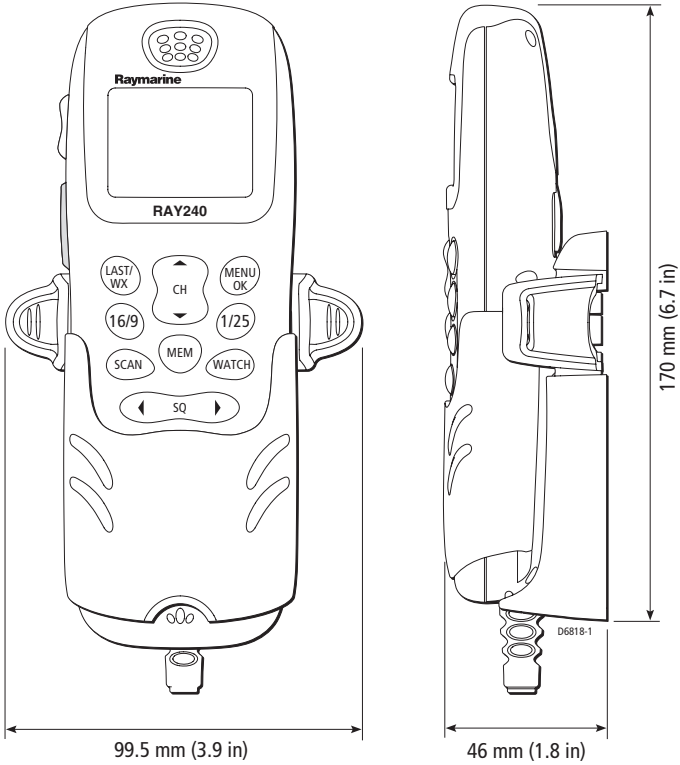

3.6 How do I make the electrical connections?

Use the combined Power/Hailer/NMEA cable to make the electrical connections, as shown:

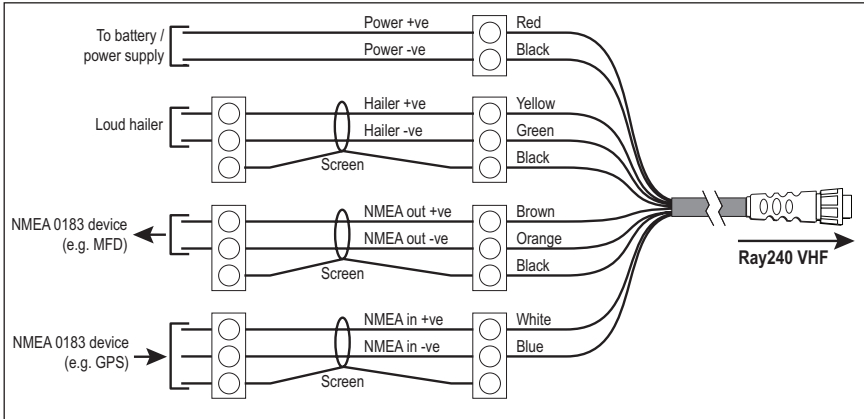

Cable color

Connection

Red

12 Volt Positive

Black

12 Volt Negative

Yellow

Hailer +

Green

Hailer -

Black

Hailer screen. Do not connect at hailer.

Brown

NMEA Out +

Orange

NMEA Out -

Black

NMEA 0183 screen. Do not connect at NMEA device.

White

NMEA In +

Blue

NMEA In -

Raymarine recommends that unused connections have the tinned ends removed and the tails are taped back to the main cable sheath.

For optimal installation, use screened cables throughout, ensuring that the screen connection is continuous.

The Ray240 base transceiver does not have an ON/OFF switch. It is therefore strongly recommended that your radio is connected to the boat's power supply through a dedicated power breaker to avoid unnecessary drain on the electrical system when your boat is not in use.

To ensure that the unit works correctly:

- You should connect the power cable to the DC supply using lugs (not supplied) that have been crimped and soldered.

Grounding

- **Connect the negative wire to battery negative.**

The negative power wire must be connected to battery negative. (Ideally the battery will be bonded to a common ground point directly adjacent to the battery itself.)

- **DO NOT connect the metal heat sink to RF ground.**

The exposed metal heatsink on the Ray240 VHF is internally connected to battery negative. No connection is required to the heatsink ground terminal. Connecting the metal heatsink to RF Ground or to the vessel's grounded metal structures will allow stray currents to flow that could cause or accelerate corrosion of metal fittings.

- **Isolate heatsink from metal objects and surfaces.**

Ensure adequate space around the metal heatsink, in particular you must avoid contact with any metal object or surface. If necessary mount the VHF on an isolating plate made of plastic or wood.

- **Isolate the antenna connector from metal objects and surfaces.**

The antenna connector (outer conductor) and coaxial cable screen are connected to the metal heatsink. Ensure the antenna connector and coaxial cable screen are isolated from any metalwork, including the mast (some metal antenna brackets may not be suitable).

How do I connect the cables to the transceiver?

You connect the cables to the labelled connectors as follows:

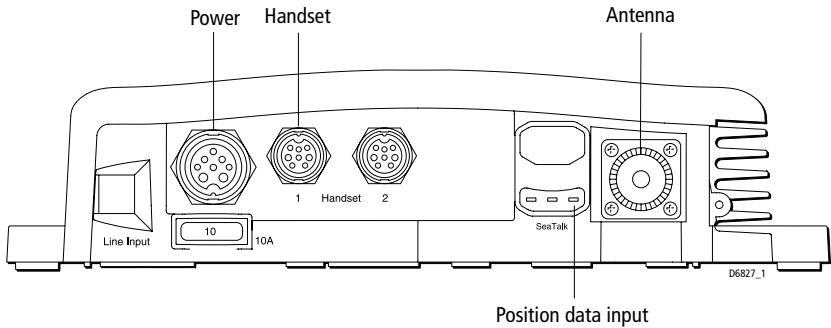

How do I connect the handset to the transceiver?

You should connect the handset cable to the transceiver using the bulkhead mounted connector. Full details of which are shown on the Installation Guide.

3.7 How do I get position data?

You can get position data for providing latitude and longitude information using either NMEA or SeaTalk connections.

SeaTalk data

If you have a SeaTalk instruments installed, this is the most convenient way to connect your radio for position data to be received. Using the SeaTalk Auxiliary Junction Box, Part No. R55006 (not supplied), enables Sea Talk and Global Positioning System (GPS) inputs to be connected in one place.

NMEA data

You should connect the White and Blue (NMEA + and -) wires of the combined cable to the output wires of the positioning device using a suitable connector block.

The following sentences are used by the Ray240:

- Receive - GGA, GLL, GNS, RMC, ZDA.
- Transmit - DSC, DSE

For specific instructions on how to connect your particular GPS, refer to the handbook which came with that device.

3.8 Setting up the Ray240

How do I

.... enter my boat's MMSI number?



Have your MMSI number ready before you start

Step 1

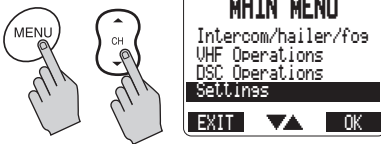

Step 2

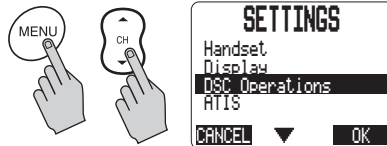

Step 3

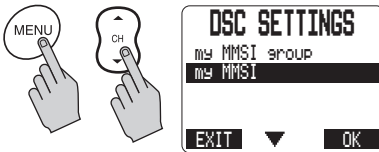

Step 4



CAUTION: MMSI NUMBER
You only get one chance to enter the MMSI number. Take care to get it right!



Step 5

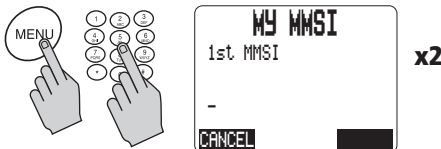

Step 6



D7156_1

- Notes:**
- (1) To change the MMSI number the radio must be returned to your Raymarine dealer.
 - (2) A group MMSI has a zero prefix.

How do I

....enter my ATIS number?



Have your ATIS number ready before you start

Step 1

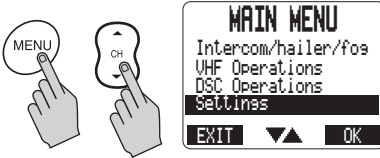

Step 2

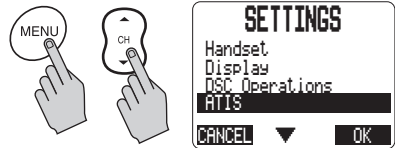

Step 3

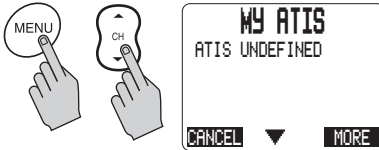

Step 4



CAUTION: ATIS NUMBER

You only get one chance to enter the ATIS number. Take care to get it right!



Step 5

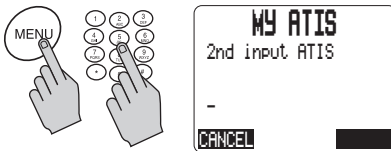

Step 6



D7157_1

- Notes:**
- (1) This procedure is only applicable to the European version of the Ray240.
 - (2) When using ATIS you cannot use DSC, Watch or Scan features.

Chapter 4: Maintenance and Troubleshooting



CAUTION

Cleaning

Do not use solvents or other chemicals to clean this equipment.

4.1 Introduction

The Ray240 is designed to provide long-term operation. It is recognized, however that environmental and other factors may result in the need for occasional service.

4.2 What maintenance can I do?

The Ray240 has no user serviceable parts or adjustments. Never remove the cover or attempt to service the product.

Your attention to a few basic points should ensure many years of service:

- Although the unit is waterproof, keep it as dry as possible.
- If you remove the handset, always fit the dust cap to the extension cable connector.
- Clean the exterior of the unit with a tissue or soft non-abrasive cloth.
- Regularly inspect the radio case and antenna for any physical damage.

4.3 How do I troubleshoot the Ray240?

All Raymarine products are, prior to packing and shipping, subjected to comprehensive test and quality assurance programs. However, if your Ray240 should develop a fault, please refer to the following table to identify the most likely cause and the suggested action required to return the radio to normal operation.

If you still have a problem after referring to the table below, contact your local Raymarine dealer, national distributor or Raymarine Technical Services Department for further advice.

Always quote the product serial number, which you will find printed on the unit.

Problem	Possible cause	Suggested action
Radio will not power up	(a) Loose wiring connection (b) 10 amp Fuse has blown	(a) Check all connections (b) Check 10 amp fuse and replace if necessary.
DSC functions are not working	MMSI number not entered	Check MMSI number has been entered correctly
Position data not shown	Information not being received from GPS	Check GPS is switched on and connected to the radio. Check units are interfaced correctly. Power cycle the Ray240 VHF

4.4 How do I get technical support?

To get Technical Support

Complete product information and interactive help is available at:
www.raymarine.com

North and South America

Raymarine Technical Support

1-800-539-5539

or

+1 603-881-5200

Product Repair and Service

Raymarine Product Repair Center
21 Manchester Street,
Merrimack,
NH 03054-4801
USA

Europe, Middle East, Africa and Australasia

Raymarine Technical Support

+44 (0) 23 9271 4713

Product Repair and Service

Raymarine UK Ltd.
Marine House
5 Harbourgate, Southampton Road,
Portsmouth, Hampshire
PO6 4BQ
England

Help us to help you

To allow us to respond to your needs faster, please quote the Equipment type, Model number and Serial number when requesting service

Appendix 5: VHF Channels

U.S. Marine VHF Channels and Frequencies

CH. No	XMIT Freq	RCV Freq	Single Freq	Use
01A	156.050	156.050	x	Port Operations and Commercial, VTS. Available only in New Orleans / Lower Mississippi area. ¹
03A	156.150	156.150	x	U.S. Government only
05A	156.250	156.250	x	Port Operations or VTS in the Houston, New Orleans and Seattle areas.
06	156.300	156.300	x	Intership Safety
07A	156.350	156.350	x	Commercial
08	156.400	156.400	x	Commercial (Intership only)
09	156.450	156.450	x	Boater Calling. Commercial and Non-Commercial.
10	156.500	156.500	x	Commercial
11	156.550	156.550	x	Commercial. VTS in selected areas.
12	156.600	156.600	x	Port Operations. VTS in selected areas.
13	156.650	156.650	x	Intership Navigation Safety (Bridge-to-bridge). Ships >20meters in length maintain a listening watch on this channel in US waters. ^{2, 6}
14	156.700	156.700	x	Port Operations. VTS in selected areas.
15	–	156.750	x	Environmental (Receive only). Used by Class 'C' EPIRBs. ³
16	156.800	156.800	x	International Distress, Safety and Calling. Ships required to carry radio, USCG, and most coast stations maintain a listening watch on this channel. ⁴
17	156.850	156.850	x	State Control ⁵
18A	156.900	156.900	x	Commercial
19A	156.950	156.950	x	Commercial
20	157.000	161.600		Port Operations (duplex)
20A	157.000	157.000	x	Port Operations

CH. No	XMIT Freq	RCV Freq	Single Freq	Use
21A	157.050	157.050	x	U.S. Coast Guard only
22A	157.100	157.100	x	Coast Guard Liaison and Maritime Safety Information Broadcasts. Broadcasts announced on channel 16.
23A	157.150	157.150	x	U.S. Coast Guard only
24	157.200	161.800		Public Correspondence (Marine Operator)
25	157.250	161.850		Public Correspondence (Marine Operator)
26	157.300	161.900		Public Correspondence (Marine Operator)
27	157.350	161.950		Public Correspondence (Marine Operator)
28	157.400	162.000		Public Correspondence (Marine Operator)
61A	156.075	156.075	x	U.S. Government only
63A	156.175	156.175	x	Port Operations and Commercial, VTS. Available only in New Orleans / Lower Mississippi area.
64A	156.225	156.225	x	U.S. Coast Guard only
65A	156.275	156.275	x	Port Operations
66A	156.325	156.325	x	Port Operations
67	156.375	156.375	x	Commercial. Used for Bridge-to-bridge communications in lower Mississippi River. Intership only. ⁶
68	156.425	156.425	x	Non-Commercial
69	156.475	156.475	x	Non-Commercial
71	156.575	156.575	x	Non-Commercial
72	156.625	156.625	x	Non-Commercial (Intership only)
73	156.675	156.675	x	Port Operations
74	156.725	156.725	x	Port Operations
77	156.875	156.875	x	Port Operations (Intership only) ⁵
78A	156.925	156.925	x	Non-Commercial
79A	156.975	156.975	x	Commercial. Non-Commercial in Great Lakes only.

CH. No	XMIT Freq	RCV Freq	Single Freq	Use
80A	157.025	157.025	x	Commercial. Non-Commercial in Great Lakes only
81A	157.075	157.075	x	U.S. Government only – Environmental protection operations.
82A	157.125	157.125	x	U.S. Government only
83A	157.175	157.175	x	U.S. Coast Guard only
84	157.225	161.825		Public Correspondence (Marine Operator)
85	157.275	161.875		Public Correspondence (Marine Operator)
86	157.325	161.925		Public Correspondence (Marine Operator)
87	157.375	161.975		Public Correspondence Marine Operator)
88	157.425	162.025		Public Correspondence only near Canadian border
88A	157.425	157.425	x	Commercial, Internship only

- Recreational boaters normally use channels listed as Non-Commercial: 68, 69, 71, 72, 78A.
- Channel 70 is used exclusively for Digital Selective Calling (DSC) and is not available for regular voice communications.
- Channels 75 and 76 are reserved as guard bands for Channel 16 and are not available for regular voice communications.

Notes:

1. The letter "A" following a channel number indicates simplex use of the ship station transmit side of an international semi-duplex channel. Operations are different from that of international operations on that channel.
2. Channel 13 should be used to contact a ship when there is danger of collision. All ships of length 20 meters or greater are required to guard VHF channel 13, in addition to VHF channel 16, when operating within U.S. territorial waters.
3. Channel is Receive Only.
4. Channel 16 is used for calling other stations or for distress alerting.
5. Output power is fixed at 1 watt only.
6. Output power is initially set to 1 watt. User can temporarily override this restriction to transmit at high power.

Canadian Marine VHF Channels and Frequencies

CH No.	XMIT Freq	RCV Freq	Area of Operation	Use
01	156.050	160.650	PC	Public Correspondence
02	156.100	160.700	PC	Public Correspondence
03	156.150	160.750	PC	Public Correspondence
04A	156.200	156.200	PC	Intership, Ship/Shore and Safety: Canadian Coast Guard search and rescue ¹
04A	156.200	156.200	EC	Intership, Ship/Shore and Commercial: Commercial fishing only
05A	156.250	156.250		Ship Movement
06	156.300	156.300	All areas	Intership, Commercial, Non-commercial and Safety: May be used for search and rescue communications between ships and aircraft.
07A	156.350	156.350	All areas	Intership, Ship/Shore, Commercial
08	156.400	156.400	WC, EC	Intership, Commercial and Safety: Also assigned for operations in the Lake Winnipeg area.
09	156.450	156.450	AC	Intership, Ship/Shore, Commercial, Non-commercial and Ship Movement: May be used to communicate with aircraft and helicopters in predominantly maritime support operations.
10	156.500	156.500	AC, GL	Intership, Ship/Shore, Commercial, Non-commercial, Safety and Ship Movement: May also be used for communications with aircraft engaged in coordinated search and rescue and antipollution operations.
11	156.550	156.550	PC, AC, GL	Intership, Ship/Shore, Commercial, Non-commercial and Ship Movement: Also used for pilotage purposes.
12	156.600	156.600	WC, AC, GL	Intership, Ship/Shore, Commercial, Non-commercial and Ship Movement: Port operations and pilot information and messages.
13	156.650	156.650	All areas	Intership, Commercial, Non-commercial and Ship Movement: Exclusively for bridge-to-bridge navigational traffic. Limited to 1-watt maximum power.

CH No.	XMIT Freq	RCV Freq	Area of Operation	Use
14	156.700	156.700	AC, GL	Intership, Ship/Shore, Commercial, Non-commercial and Ship Movement: Port operations and pilot information and messages.
15	156.750	156.750	All areas	Intership, Ship/Shore, Commercial, Non-commercial and Ship Movement: All operations limited to 1-watt maximum power. May also be used for on-board communications.
16	156.800	156.800	All areas	International Distress, Safety and Calling ²
17	156.850	156.850	All areas	Intership, Ship/Shore, Commercial, Non-commercial and Ship Movement: All operations limited to 1-watt maximum power. May also be used for on-board communications.
18A	156.900	156.900	All areas	Intership, Ship/Shore and Commercial: Towing on the Pacific Coast.
19A	156.950	156.950	All areas except PC	Intership and Ship/Shore: Canadian Coast Guard only.
19A	156.950	156.950	PC	Intership and Ship/Shore: Various Government departments.
20	157.000	161.600	All areas	Ship/Shore, Safety and Ship Movement: Port operations only with 1-watt maximum power.
21A	157.050	157.050	All areas	Intership and Ship/Shore: Canadian Coast Guard only.
21B	-	161.650	All areas	Safety: Continuous Marine Broadcast (CMB) service. ³
22A	157.100	157.100	All areas	Intership, Ship/Shore, Commercial and Non-commercial: For communications between Canadian Coast Guard and non-Canadian Coast Guard stations only.
23	157.150	161.750	PC	Ship/Shore and Public Correspondence: Also in the inland waters of British Columbia and the Yukon.
24	157.200	161.800	All areas	Ship/Shore and Public Correspondence
25	157.250	161.850	PC	Ship/Shore and Public Correspondence: Also assigned for operations in the Lake Winnipeg area.
25B	-	161.850	AC	Safety: Continuous Marine Broadcast (CMB) service.
26	157.300	161.900	All areas	Ship/Shore, Safety and Public Correspondence

CH No.	XMIT Freq	RCV Freq	Area of Operation	Use
27	157.350	161.950	AC, GL, PC	Ship/Shore and Public Correspondence
28	157.400	162.000	PC	Ship/Shore, Safety and Public Correspondence
28B	-	162.000	AC	Safety: Continuous Marine Broadcast (CMB) service.
60	156.025	160.625	PC	Ship/Shore and Public Correspondence
61A	156.075	156.075	PC	Intership and Ship/Shore: Canadian Coast Guard only.
61A	156.075	156.075	EC	Intership, Ship/Shore and Commercial: Commercial fishing only.
62A	156.125	156.125	PC	Intership and Ship/Shore: Canadian Coast Guard only.
62A	156.125	156.125	EC	Intership, Ship/Shore and Commercial: Commercial fishing only.
64	156.225	160.825	PC	Ship/Shore and Public Correspondence
64A	156.225	156.225	EC	Intership, Ship/Shore and Commercial: Commercial fishing only.
65A	156.275	156.275		Intership, Ship/Shore, Commercial, Non-commercial, Safety: Search & rescue and antipollution operations on the Great Lakes. Towing on the Pacific Coast. Port operations only in the St. Lawrence River areas with 1W maximum power. Pleasure craft in the inland waters of Alberta, Saskatchewan and Manitoba (excluding Lake Winnipeg and the Red River).
66A	156.325	156.325		Intership, Ship/Shore, Commercial, Non-commercial, Safety and Ship Movement: Port operations only in the St. Lawrence River/Great Lakes Areas with 1-watt maximum power.
67	156.375	156.375	EC	Intership, Ship/Shore and Commercial: Commercial fishing only.
67	156.375	156.375	All areas except EC	Intership, Ship/Shore, Commercial, Non-commercial, Safety: May also be used for communications with aircraft engaged in coordinated search and rescue and antipollution operations.

CH No.	XMIT Freq	RCV Freq	Area of Operation	Use
68	156.425	156.425	All areas	Intership, Ship/Shore and Non-commercial: For marinas and yacht clubs.
69	156.475	156.475	All areas except EC	Intership, Ship/Shore, Commercial and Non-commercial
69	156.475	156.475	EC	Intership, Ship/Shore and Commercial: Commercial fishing only.
71	156.575	156.575	PC	Intership, Ship/Shore, Commercial, Non-commercial, Safety and Ship Movement
71	156.575	156.575		Intership, Ship/Shore and Non-commercial: For marinas and yacht clubs on the East Coast and on Lake Winnipeg.
72	156.625	156.625	EC, PC	Intership, Commercial and Non-commercial: May be used to communicate with aircraft and helicopters in predominantly maritime support operations.
73	156.675	156.675	EC	Intership, Ship/Shore and Commercial: Commercial fishing only
73	156.675	156.675	All areas except EC	Intership, Ship/Shore, Commercial, Non-commercial, Safety: May also be used for communications with aircraft engaged in coordinated search and rescue and antipollution operations.
74	156.725	156.725	EC, PC	Intership, Ship/Shore, Commercial, Non-commercial and Ship Movement.
77	156.875	156.875		Intership, Ship/Shore, Safety and Ship Movement: Pilotage on Pacific Coast. Port operations only in the St. Lawrence River/Great Lakes areas with 1W maximum power.
78A	156.925	156.925	EC, PC	Intership, Ship/Shore and Commercial
79A	156.975	156.975	EC, PC	Intership, Ship/Shore and Commercial
80A	157.025	157.025	EC, PC	Intership, Ship/Shore and Commercial
81A	157.075	157.075		Intership and Ship/Shore: Canadian Coast Guard use only in the St. Lawrence River/Great Lakes areas.
81A	157.075	157.075	PC	Intership, Ship/Shore and Safety: Canadian Coast Guard antipollution.

CH No.	XMIT Freq	RCV Freq	Area of Operation	Use
82A	157.125	157.125	PC	Intership, Ship/Shore and Safety: Canadian Coast Guard use only.
82A	157.125	157.125		Intership and Ship/Shore: Canadian Coast Guard use only in the St. Lawrence River/Great Lakes areas.
83	157.175	161.775	PC	Ship/Shore and Safety: Canadian Coast Guard use only.
83A	157.175	157.175	EC	Intership and Ship/Shore: Canadian Coast Guard and other Government agencies.
83B	-	161.775	AC, GL	Safety: Continuous Marine Broadcast (CMB) Service.
84	157.225	161.825	PC	Ship/Shore and Public Correspondence
85	157.275	161.875	AC, GL, NL	Ship/Shore and Public Correspondence
86	157.325	161.925	PC	Ship/Shore and Public Correspondence
87	157.375	161.975	AC, GL, NL	Ship/Shore and Public Correspondence
88	157.425	162.025	AC, GL, NL	Ship/Shore and Public Correspondence

Area of Operation

AC: Atlantic Coast, Gulf and St. Lawrence River up to and including Montreal

EC (East Coast): includes NL, AC, GL and Eastern Arctic areas

GL: Great Lakes (including St. Lawrence above Montreal)

NL: Newfoundland and Labrador

PC: Pacific Coast

WC (West Coast): Pacific Coast, Western Arctic and Athabasca-Mackenzie Watershed areas

All areas: includes East and West Coast areas

Notes:

1. An "A" following a channel number indicates simplex use of the ship station transmit side of an international duplex channel. Operations are different from that of international operations on that channel.
2. Channel 16 is used for calling other stations or for distress alerting.
3. The letter "B" following a channel number indicates simplex use of the coast station transmit side of an international duplex channel. That is, the channel is Receive Only.
4. Channel 70 is used exclusively for Digital Selective Calling (DSC) and is not available for regular voice communications.
5. Channels 75 and 76 are reserved as guard bands for Channel 16 and are not available for regular voice communications.

International Marine VHF Channels & Frequencies

CH No.	XMIT Freq	RCV Freq	Single Freq	Use
01	156.050	160.650		Public Correspondence, Port Operations and Ship Movement
02	156.100	160.700		Public Correspondence, Port Operations and Ship Movement
03	156.150	160.750		Public Correspondence, Port Operations and Ship Movement
04	156.200	160.800		Public Correspondence, Port Operations and Ship Movement
05	156.250	160.850		Public Correspondence, Port Operations and Ship Movement
06	156.300	156.300	x	Intership ¹
07	156.350	160.950		Public Correspondence, Port Operations and Ship Movement
08	156.400	156.400	x	Intership
09	156.450	156.450	x	Intership, Port Operations and Ship Movement
10	156.500	156.500	x	Intership, Port Operations and Ship Movement ²
11	156.550	156.550	x	Port Operations and Ship Movement
12	156.600	156.600	x	Port Operations and Ship Movement
13	156.650	156.650	x	Intership Safety, Port Operations and Ship Movement ³
14	156.700	156.700	x	Port Operations and Ship Movement
15	156.750	156.750	x	Intership and On-board Communications at 1W only ⁴
16	156.800	156.800	x	Distress, Safety and Calling
17	156.850	156.850	x	Intership and On-board Communications at 1W only ⁴
18	156.900	161.500		Public Correspondence, Port Operations and Ship Movement
19	156.950	161.550		Public Correspondence, Port Operations and Ship Movement
20	157.000	161.600		Public Correspondence, Port Operations and Ship Movement
21	157.050	161.650		Public Correspondence, Port Operations and Ship Movement
22	157.100	161.700		Public Correspondence, Port Operations and Ship Movement
23	157.150	161.750		Public Correspondence, Port Operations and Ship Movement
24	157.200	161.800		Public Correspondence, Port Operations and Ship Movement

CH No.	XMIT Freq	RCV Freq	Single Freq	Use
25	157.250	161.850		Public Correspondence, Port Operations and Ship Movement
26	157.300	161.900		Public Correspondence, Port Operations and Ship Movement
27	157.350	161.950		Public Correspondence, Port Operations and Ship Movement
28	157.400	162.000		Public Correspondence, Port Operations and Ship Movement
60	156.025	160.625		Public Correspondence, Port Operations and Ship Movement
61	156.075	160.675		Public Correspondence, Port Operations and Ship Movement
62	156.125	160.725		Public Correspondence, Port Operations and Ship Movement
63	156.175	160.775		Public Correspondence, Port Operations and Ship Movement
64	156.225	160.825		Public Correspondence, Port Operations and Ship Movement
65	156.275	160.875		Public Correspondence, Port Operations and Ship Movement
66	156.325	160.925		Public Correspondence, Port Operations and Ship Movement
67	156.375	156.375	x	Intership, Port Operations and Ship Movement ²
68	156.425	156.425	x	Port Operations and Ship Movement
69	156.475	156.475	x	Intership, Port Operations and Ship Movement
71	156.575	156.575	x	Port Operations and Ship Movement
72	156.625	156.625	x	Intership
73	156.675	156.675	x	Intership ²
74	156.725	156.725	x	Port operations and Ship movement
75	156.775	156.775	x	See Note 5
76	156.825	156.825	x	See Note 5
77	156.875	156.875	x	Intership
78	156.925	161.525		Public correspondence, Port Operations and Ship Movement
79	156.975	161.575		Public correspondence, Port Operations and Ship Movement
80	157.025	161.625		Public correspondence, Port Operations and Ship Movement
81	157.075	161.675		Public correspondence, Port Operations and Ship Movement

CH No.	XMIT Freq	RCV Freq	Single Freq	Use
82	157.125	161.725		Public correspondence, Port Operations and Ship Movement
83	157.175	161.775		Public correspondence, Port Operations and Ship Movement
84	157.225	161.825		Public correspondence, Port Operations and Ship Movement
85	157.275	161.875		Public correspondence, Port Operations and Ship Movement
86	157.325	161.925		Public correspondence, Port Operations and Ship Movement
87	157.375	157.375	x	Port Operations and Ship Movement
88	157.425	157.425	x	Port Operations and Ship Movement

- Intership channels are for communications between ship stations. Intership communications should be restricted to Channels 6, 8, 72 and 77. If these are not available, the other channels marked for Intership may be used.
- Channel 70 is used exclusively for Digital Selective Calling (DSC) and is not available for regular voice communications.

Notes:

1. Channel 06 may also be used for communications between ship stations and aircraft engaged in coordinated search and rescue operations. Ship stations should avoid harmful interference to such communications on channel 06 as well as to communications between aircraft stations, ice breakers and assisted ships during ice seasons.
2. Within the European Maritime Area and in Canada, channels 10, 67 and 73 may also be used by the individual administrations concerned for communication between ship stations, aircraft stations and participating land stations engaged in coordinated search and rescue and anti-pollution operations in local areas. Channels 10 or 73 (depending on location) are also used for the broadcast of Marine Safety Information by the Maritime and Coast Guard Agency in the UK only.
3. Channel 13 is designated for use on a worldwide basis as a navigation safety communication channel, primarily for intership navigation safety communications.
4. Channels 15 and 17 may also be used for on-board communications provided the effective radiated power does not exceed 1 Watt.
5. The use of Channels 75 and 76 should be restricted to navigation related communication only and all precautions should be taken to avoid harmful interference to channel 16. Transmit power is limited to 1 Watt.

WX Channels (North America only)

Weather Channel	Frequency in MHz
WX 1	162.550
WX 2	162.400
WX 3	162.475
WX 4	162.425
WX 5	162.450
WX 6	162.500
WX 7	162.525
WX 8	161.650
WX 9	161.775
WX 10	163.275

Private Channels

Country	Channel Designation	Channel use
United Kingdom	M1 M2	Pleasure Boat Pleasure Boat
Denmark	L1 L2	Pleasure Boat Pleasure Boat
Finland, Norway & Sweden	L1 L2 L3	Pleasure Boat Pleasure Boat Pleasure Boat
Netherlands	31 37	NL Marina UK Marina
Denmark, Finland, Norway & Sweden	F1 F2 F3	Fishing Boat Fishing Boat Fishing Boat

These National channels have been allocated for the specific use within those countries listed. To use them you must have the appropriate license and your Ray240 must be programmed

by an authorized Raymarine dealer to use the national channels that are approved for your country.

Appendix 6: Technical specification

Transmitter

Channels	All available US, International and Canadian VHF Marine Band
Frequency Stability	± 1.5 kHz
Frequency Range	155.000 - 165.000 MHz
Channel Spacing	25 kHz
Power Output	25 W / 1 W
Modulation	Frequency modulation
Modulation Audio Response	+1 to -30dB of 6db/ octave 300 Hz to 3000 Hz
FM Hum & Noise level	< -40 dB
Audio Distortion	< 10%
Spurious & Harmonic (25W)	better than 80 dB
Antenna Impedance	50 ohms

Receiver

Channels	All available US, International and Canadian VHF Marine Band
Frequency Range	155.000 - 165.000 MHz
Frequency Stability	± 1.5 kHz
Usable Sensitivity (20dB) SINAD	<0.4 μ V
Squelch Sensitivity	<0.2 μ V
Adjacent Channel Rejection	> 70 dB
Spurious Image Rejection	> 70 dB
Inter modulation Rejection	> 68 dB

Audio Output (active speaker)	5W
Audio distortion	< 5%
Hum & Noise in Audio	< -40 dB

Hailer

Output - 4 Ohms	22W
- 8 Ohms	10W

Operating requirements

Input Voltage	12V nominal (10.8 to 15.6)
Current consumption (single handset system)	
Receive	400 mA
Standby	110 mA
Current 25W @ 13.8V transmit	< 6 amps
Temperature Range	14 ⁰ F to + 122 ⁰ F (-10 ⁰ C to +50 ⁰ C) operational -4 ⁰ F to + 158 ⁰ F (-20 ⁰ C to +70 ⁰ C) non-operating
Water Protection	Handset - submersible to IPX 7 Active speaker - waterproof to CFR 46 Transceiver unit - drip resistant

Appendix 7: Hints and Tips

Phonetic Alphabet

To help make call letters more clearly understood, and to assist in spelling out similar sounding or unfamiliar word, radiotelephone users employ the international phonetic alphabet.

A	ALPHA	N	NOVEMBER
B	BRAVO	O	OSCAR
C	CHARLIE	P	PAPA
D	DELTA	Q	QUEBEC
E	ECHO	R	ROMEO
F	FOXTROT	S	SIERRA
G	GOLF	T	TANGO
H	HOTEL	U	UNIFORM
I	INDIA	V	VICTOR
J	JULIET	W	WHISKEY
K	KILO	X	X-RAY
L	LIMA	Y	YANKEE
M	MIKE	Z	ZULU

Prowords

Prowords can be used to simplify and speed up radio communications.

Proword	Meaning
ACKNOWLEDGE	Have you received and understood?
CONFIRM	My version is..... is that correct?
CORRECTION	An error has been made; the correct version is.....
I SAY AGAIN	I repeat.... (e.g. important words)
I SPELL	What follows is spelt phonetically
OUT	End of work
OVER	I have completed this part of my message, and I am inviting you to reply
RECEIVED	Receipt acknowledged
SAY AGAIN	Repeat your message (or the part indicated)
STATION CALLING	Used when a station is uncertain of the identity of a station which is calling

Appendix 8: List Of Abbreviations

Abbreviation Meaning

A	Amperes
ATIS	Automatic Transmission Identification System
dB	Decibels
dc	Direct Current
DSC	Digital Selective Calling
DTMF	Dual Tone Multi-Frequency
EMC	Electromagnetic Compatibility
EME	Electromagnetic Energy
FCC	Federal Communications Commission
GMDSS	Global Maritime Distress and Safety System
GPS	Global Positioning System
Hz	Hertz
kHz	Kilo Hertz
LCD	Liquid Crystal Display
MHz	Mega Hertz
mm	millimeters
MMSI	Maritime Mobile Service Identity
NMEA	National Marine Electronics Association
NOAA	National Oceanographic and Atmospheric Administration
PTT	Push To Talk
RF	Radio Frequency
RX	Receiver
SWR	Standing Wave Ratio
TX	Transmit

Abbreviation Meaning

UK	United Kingdom
V	Volts
VHF	Very High Frequency